

The Imaging Source "23" Series GigE Camera

DMK 23GP031 / DFK 23GP031



The Imaging Source DMK 23GP031 (monochrome) and DFK 23GP031 (color) Gigabit Ethernet cameras are the perfect solution for many industrial automation, quality assurance, security, surveillance, and medical applications. Utilizing the very sensitive Aptina 5 Megapixel MT9P031 monochrome and color rolling shutter CMOS sensors, these cameras feature a variety of input, output, strobe, and trigger options via an external 6-pin Hirose port. With up to 15 fps and a trigger delay of less than 5 micro seconds, the DMK 23GP031 and DFK 23GP031 Gigabit Ethernet cameras from The Imaging Source are a very low cost, yet highly versatile imaging solution.

Included :

- Camera, CS to C mount adapter and tripod mount
- Drivers compatible to WDM, DirectShow, DirectX®, TWAIN, ActivVisionTools, HALCON, VfW and LabVIEW® for Windows 7/8, Windows Vista, and Windows XP
- IC Capture camera control and acquisition software for Windows 7/8, Windows Vista, and Windows XP (32 and 64 bit versions)
- IC Imaging Control Software Development Kit (SDK) including a .NET component, an ActiveX component, and a C++ class library for Windows

Features :

- Variable trigger (4 μ s to 1s)
- Digital I/O strobe
- CS with C mount adapter
- Binning and ROI (CMOS only)
- Power over Ethernet
- Direct power optional
- Optional external DC driven auto iris controller

Accessories :

- CS to M12 adapters
- C, CS, and M12 lenses
- 12VDC power supply
- CAT 6A Cable
- 6-pin Hirose break-out cable
- External power and trigger cable

Specification : DMK 23GP031 (Monochrome)

GENERAL BEHAVIOR

Video formats @ Frame rate	2592x1944 Y800 @ 15, 7.5, 3.75 fps 2592x1944 Y16 @ 15, 7.5, 3.75 fps
Sensitivity	0.015 lx
Dynamic range	8 / 12 bit

INTERFACE (OPTICAL)

IR cut filter	no
Sensor specification	MT9P031
Shutter	Rolling
Format	1/2.5 "
Resolution	H: 2592, V: 1944
Pixel size	H: 2.2 μ m, V: 2.2 μ m
Lens mount	C/CS

INTERFACE (ELECTRICAL)

Supply voltage	11 to 13 VDC or 48 to 56 PoE
Current consumption	approx. 400 mA at 12 VDC

INTERFACE (MECHANICAL)

Dimensions	H: 29 mm, W: 29 mm, L: 57 mm
Mass	65 g

ADJUSTMENTS (MANUAL)

Shutter	1/100,000 to 30 s
Gain	0 to 36 dB

ADJUSTMENTS (AUTOMATIC)

Shutter	1/100,000 to 30 s
Gain	0 to 36 dB

ENVIRONMENTAL

Max. temperature (operation)	-5 °C to 45 °C
Max. temperature (storage)	-20 °C to 60 °C
Max. humidity (operation)	20 % to 80 % non-condensing
Max. humidity (storage)	20 % to 95 % non-condensing

Specification : DFK 23GP031 (Color)

GENERAL BEHAVIOR	
Video formats @ Frame rate	2592x1944 RGB32 @ 15, 7.5, 3.75 fps 2592x1944 Y800 @ 15, 7.5, 3.75 fps 2592x1944 Y16 @ 15, 7.5, 3.75 fps
Sensitivity	0.05 lx
Dynamic range	8 / 12 bit

INTERFACE (OPTICAL)	
IR cut filter	yes
Sensor specification	MT9P031
Shutter	Rolling
Format	1/2.5 "
Resolution	H: 2592, V: 1944
Pixel size	H: 2.2 μm , V: 2.2 μm
Lens mount	C/CS

INTERFACE (ELECTRICAL)	
Supply voltage	11 to 13 VDC or 48 to 56 PoE
Current consumption	approx. 400 mA at 12 VDC

INTERFACE (MECHANICAL)	
Dimensions	H: 29 mm, W: 29 mm, L: 57 mm
Mass	65 g

ADJUSTMENTS (MANUAL)	
Shutter	1/100,000 to 30 s
Gain	0 to 36 dB
White balance	-2 dB to +6 dB

ADJUSTMENTS (AUTOMATIC)	
Shutter	1/100,000 to 30 s
Gain	0 to 36 dB
White balance	-2 dB to +6 dB

ENVIRONMENTAL	
Max. temperature (operation)	-5 °C to 45 °C
Max. temperature (storage)	-20 °C to 60 °C
Max. humidity (operation)	20 % to 80 % non-condensing
Max. humidity (storage)	20 % to 95 % non-condensing

Monochrome Spectral Response Curve

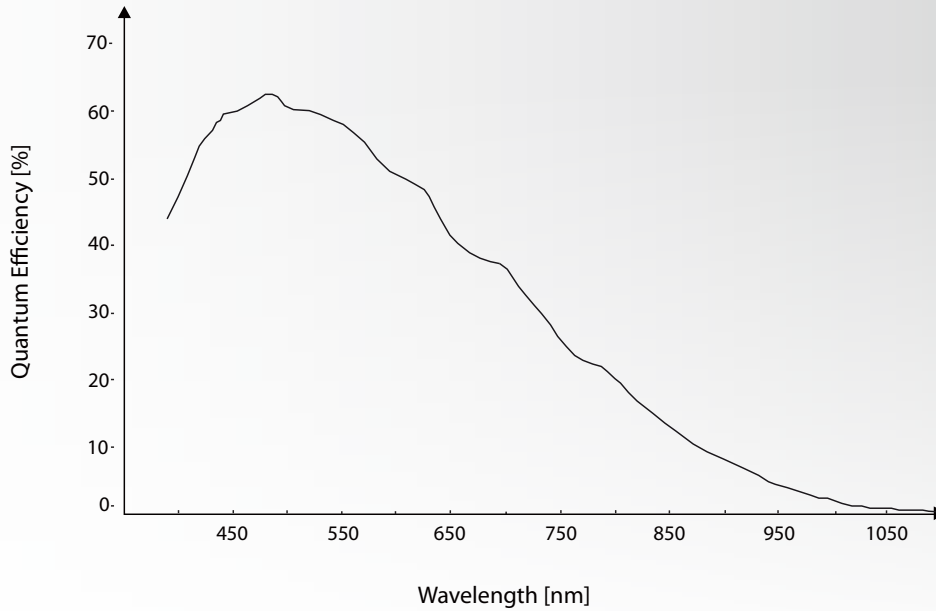

Sensor: Micron MT9P031 M - courtesy of Aptina Deutschland GmbH

Color Spectral Response Curve

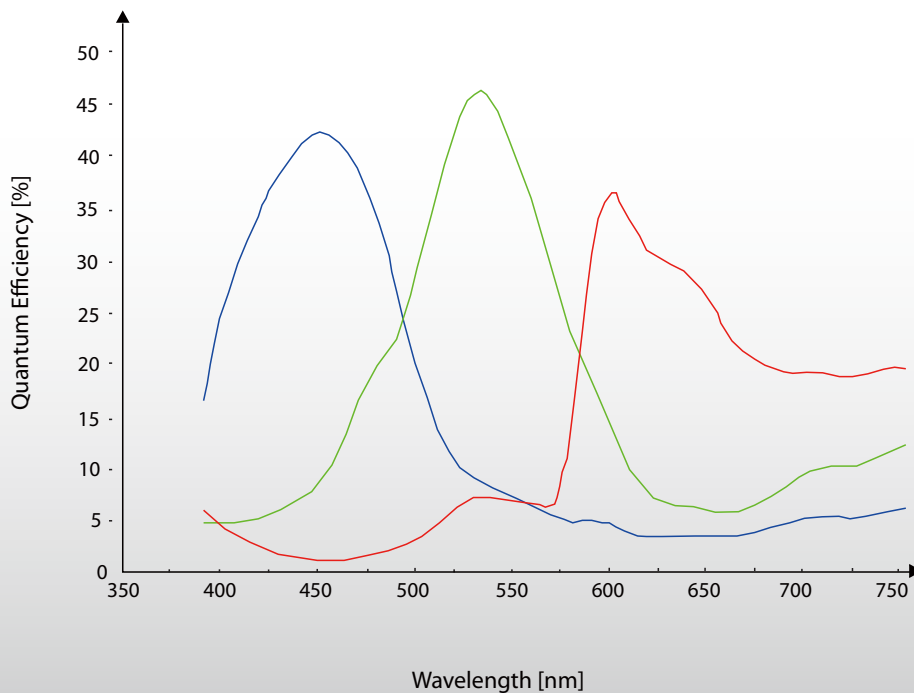

Sensor: Micron MT9P031 C - courtesy of Aptina Deutschland GmbH

DMK 23GP031 / DFK 23GP031 Dimensional Diagram

(with tripod adapter)

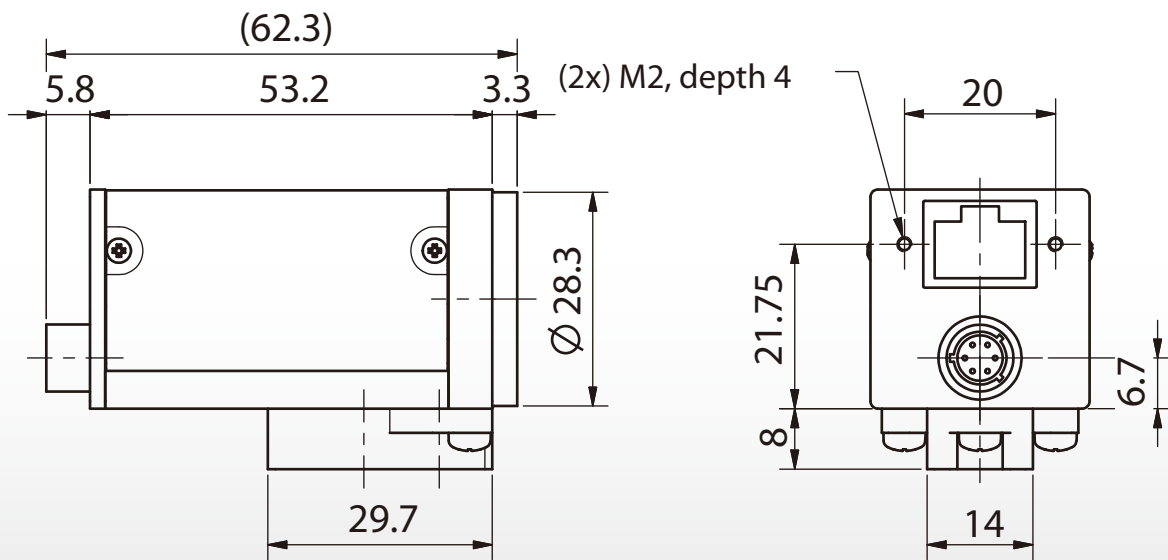
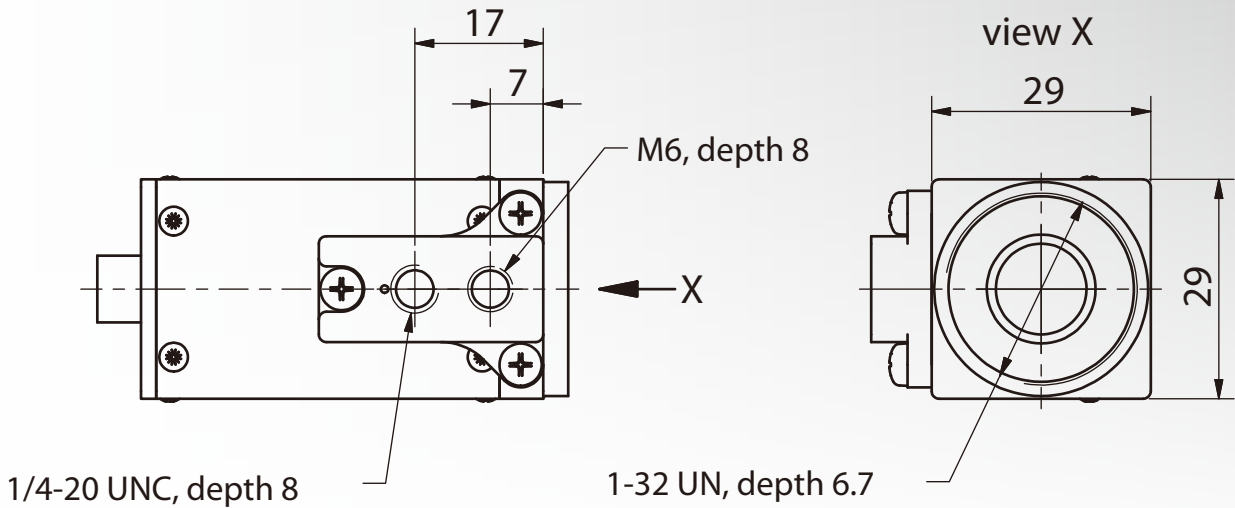

Dimensions: mm
Tolerances: DIN ISO 2768m



DMK 23GP031 / DFK 23GP031 Dimensional Diagram

(without tripod adapter)

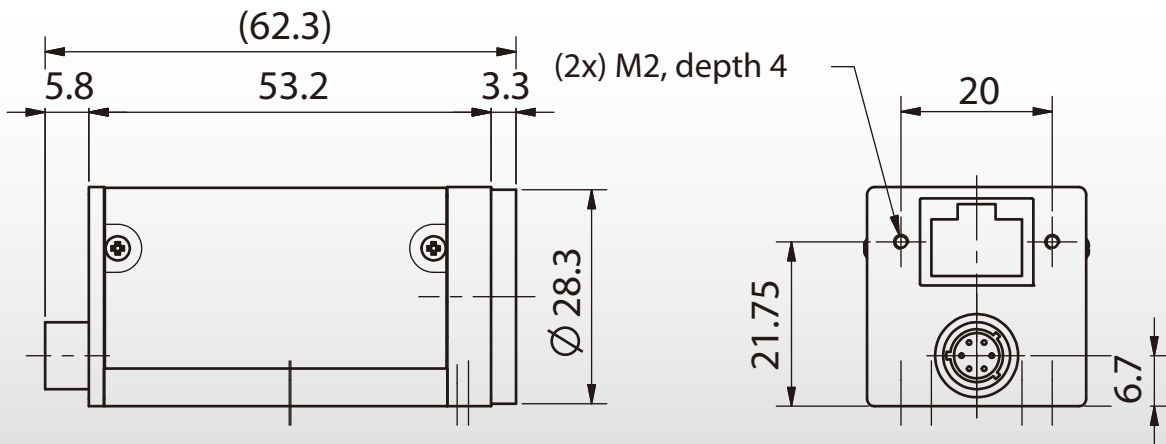
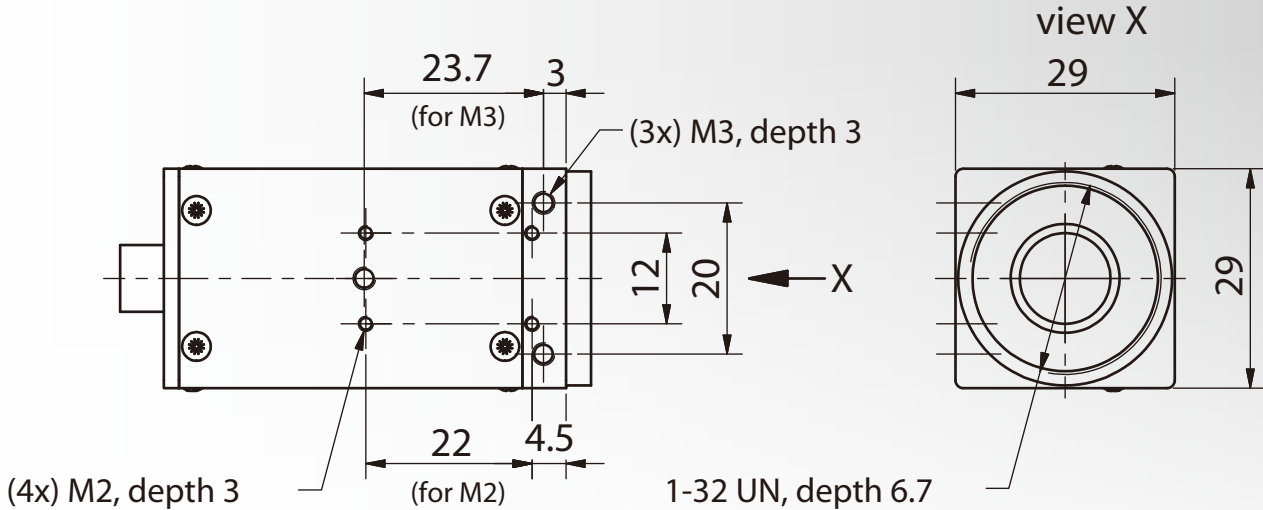

Dimensions: mm
Tolerances: DIN ISO 2768m



Headquarters : The Imaging Source Europe GmbH
Sommerstrasse 36, D-28215 Bremen, Germany
Phone: +49 421-33591-0

North & South America : The Imaging Source, LLC
6926 Shannon Willow Rd., S 400, Charlotte, NC 28226, USA
Phone: +1 704-370-0110

Asia Pacific : The Imaging Source Asia Co., Ltd.
6F-1, No.230, Sec.3, Ba-De Rd., Taipei City 10555, Taiwan
Phone: +886 2-2577-1228

www.theimagingsource.com

All product and company names in this document may be trademarks and tradenames of their respective owners and are hereby acknowledged. The Imaging Source Europe GmbH cannot and does not take any responsibility or liability for any information contained in this document. The source code presented in this document is exclusively used for didactic purposes. The Imaging Source does not assume any kind of warranty expressed or implied, resulting from the use of the content of this document or the source code.

The Imaging Source Company reserves the right to make changes in specifications, function or design at any time and without prior notice.
Last update: October, 2012
Copyright © 2012 The Imaging Source Europe GmbH
All rights reserved. Reprint, also in parts, only allowed with permission of The Imaging Source Europe GmbH, fs23p031.en_US.pdf

All weights and dimensions are approximate. Unless otherwise specified the lenses shown in the context of cameras are not shipped with these cameras.