

Sensor Information

Model Name	ON Semiconductor Python 1300
Type	1/2" progressive scan CMOS
Shutter	Global Shutter
Resolution	1280 x 1024 pixels
Scan Area	6.14 mm x 4.91 mm
Pixel Size	4.8 μm x 4.8 μm

Data Quality

@ 20 °C, gain = 1, exposure time = 4 msec

Dark Noise (σ)	10 e- typical
Saturation	7300 e- typical
Dynamic Range	57 dB typical
SNR	39 dB typical
Quantum efficiency η	56 % @ 536 nm typical

Acquisition

Resolution	1280 px x 1024 px		
Interface Frame Rate	Format	Resolution	max. Frame Rate
(depends on used interface performance)			
Full Frame	1280 x 1024	94 fps	
Binning 2x2	640 x 512	148 fps	
Binning 2x1	640 x 1024	148 fps	
Binning 1x2	1280 x 512	148 fps	

Acquisition Frame Rate ¹⁾ 146 fps | $t_{readout} = 6.81$ msec (max. Res. Full Frame) @ 10 bit (Burst Mode)

Pixel Formats	Mono8, Mono10
Partial Scan	True Partial Scan with increasing Frame Rate on X and Y direction, Region of Interest (ROI) arbitrary
	Width: minimum 24, increment 8
	Height: minimum 1, increment 1

Adjustable Acquisition Frame Rate	Off or Off or 0.01 ... 65535 Hz
Acquisition Mode	Continuous, Single Frame and Multi Frame
Acquisition Status	AcquisitionActive, AcquisitionTrigger Wait
Exposure Mode	Timed
Readout Mode	Overlapped, Sequential

Image Pre-Processing

Analog Controls	Exposure Time (20 μsec ... 1 sec Step Size 1 μsec) Gain (0...18 dB), Offset (0 ... 63 LSB 10 bit)
Auto Function	ExposureAuto and GainAuto with BrightnessAutoPriority based on BrightnessAuto ROI

LUT	Luminance (12 bit)
Color Models	Mono
Color Processing	-
Color Adjustment	-
Color Enhancement	-
Color Tolerance	-

¹⁾ Sensor readout, different from pixel format

²⁾ depends on the used interface

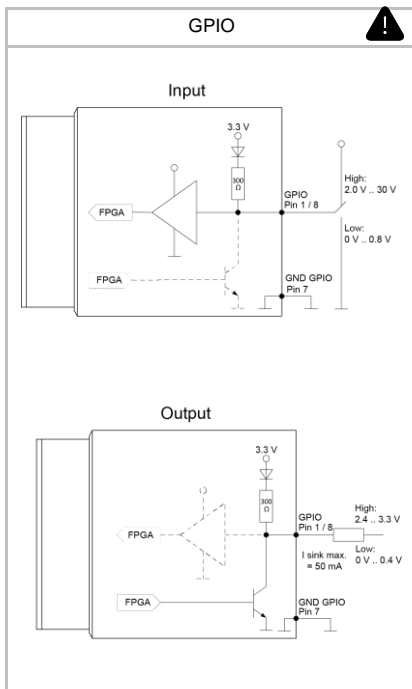
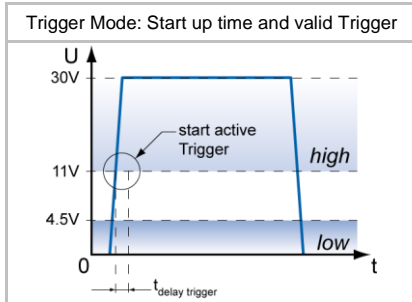
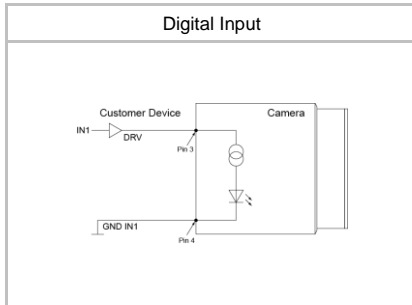
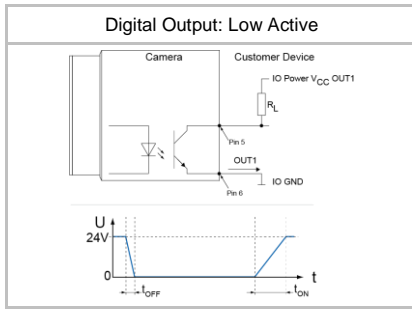

¹⁾ Sensor readout, different from pixel format

Image Pre-Processing

Binning Horizontal	1 or 2
Binning Vertical	1 or 2
Image Flipping	Horizontal, vertical
Defect Pixel Correction	via Defect Pixel List with up to 512 Pixel Coordinates
Fix Pattern Noise Correction	yes

Process Synchronization

Trigger Mode	Off (Free Running), On (Trigger)
Trigger Overlap Type	Readout
Trigger Sources	Hardware (Line0, 1, 2), Software, Counter 1, 2 End, Action CMD (Action 1), All or Off fixed Trigger Delay out of t _{readout} : ¹⁾ 6 μsec @ 10 bit max. Trigger Delay during t _{readout} : ¹⁾ 12 μsec @ 10 bit
Trigger Delay	0 ... 2 sec, Tracking and buffering of up to 256 triggers
External Flash Sync	via Exposure Active t _{delay flash} ≤ 3 μsec, t _{duration} = t _{exposure}
Encoder Function	yes, via Counter and Trigger Source
PTP Function	-

Digital I/Os

Lines	Input: Line 0, Output: Line3, GPIO: Line 1, Line 2
Output Sources	Off, ExposureActive, Timer1, ReadoutActive, UserOutput 1-3 and TriggerReady
Line Debouncer	Low and high signal separately selectable Debouncing Time 0 ... 5 msec, Step Size: 1 μsec

Memory

Image Buffer	60 MB 16 Images (Trigger Mode) / 1 Image (Free Running Mode)
Non-volatile Memory	128 kb

Network Interface Data

Interface	Gigabit Ethernet 1000BASE-T 1000 Mbits/sec Fast Ethernet 100 BASE-T 100 Mbits/sec
Ethernet IP Configuration	Persistent IP, DHCP, LLA
Packet Size	576 ... 9000 Byte, Jumbo Frames supported

GigE Vision® Features

Events Transmission via Asynchronous Message Channel	DeviceTemperatureStatusChanged, EventLost, ExposureEnd, ExposureStart, FrameEnd, FrameStart, FrameTransferSkipped, GigE VisionError, GigE VisionHeartbeatTimeout, PrimaryApplicationSwitch, Line0..2 FallingEdge, Line0..2 RisingEdge, TransferBufferFull, TransferBufferReady, TriggerOverlapped, TriggerReady, TriggerSkipped
Action CMD	yes, Action 1 for Trigger
Frame Counter	up to 2 ³²
Payload Size	0 ... 2621664 Byte
Timestamp	64 bit, resolution in nsec, increment = 8
Packet Delay	0 .. 2 ³² - 1 nsec
Packet Resend	Resend Buffer: 40 MB (16 Images)
GigE Vision	v2.0 (v1.2 backward compatible)

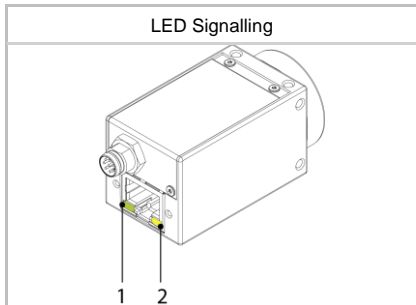
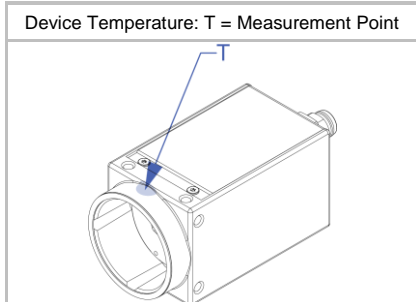
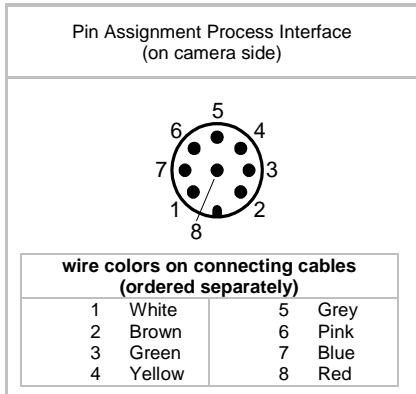
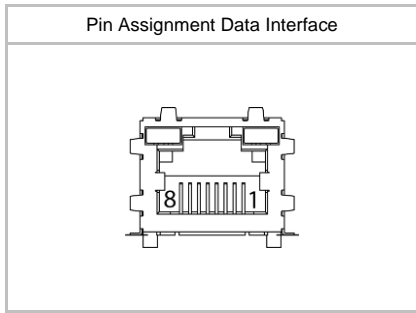

Interfaces and Connectors

Data and Power Interface	Gigabit Ethernet	Transfer Rate	1000 Mbits/sec
	Fast Ethernet	Transfer Rate	100 Mbits/sec
	Connector:	8P8C Modular Jack (RJ45), screw lock type	
	Assignment:	1 - MX1+	2 - MX1-
		3 - MX2+	4 - MX3+
		5 - MX3-	6 - MX2-
		7 - MX4+	8 - MX4-
Process Interface	Connector:	M8/8-pin (SACC-DSI-M8MS-8CON-M8-L180)	
	Assignment:	1 - GPIO (Line2)	2 - Power Vcc
		3 - IN1 (Line0)	4 - GND IN1
		5 - Power VCC OUT	6 - OUT1 (Line3)
		7 - GND (Power, GPIO)	8 - GPIO (Line1)

Caution * Note GPIOs: Ground loops are to be avoided and can lead to destruction of the device.

Optical Data

Lens Mount	C-Mount
Optical Filter	-

Mechanical Data

Housing	Zinc die casting, baked varnish (until 02-2020 nickel-chrome-plated)
Protection Class	IP40 (with mounted lens and GigE cable)
Weight	120 g
Dimensions	

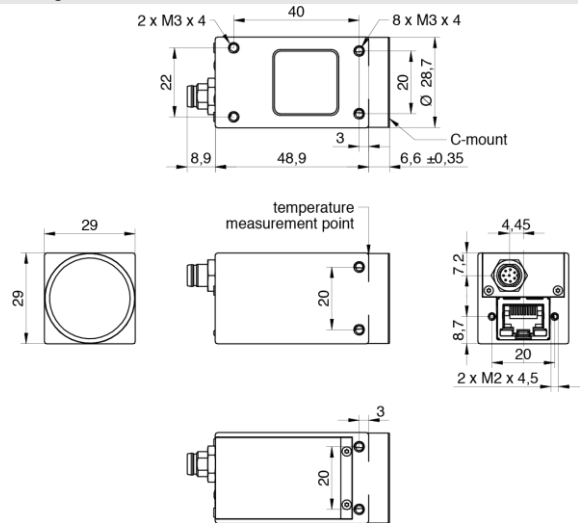

Environmental Data

Storage Temperature	-10 °C ... +70 °C
Operating Temperature	0 °C ... +65 °C @ T = Measurement Point or 0 °C ... +75 °C @ internal Temperature Sensor Ambient temperature above 34 °C requires heat dissipation measures.
Int. Temperature Sensor	yes, accuracy: ±2 °C (typ) -40 °C ... 0 °C ±1 °C (typ) 0 °C ... +85 °C
Humidity	10 % ... 90 % non-condensing

LED Signalling

LED	LED 1	Green static	Link ON
		Green flash	RX active
	LED 2	Yellow static	Error
		Yellow flash	TX active

Electrical Data

Power Supply (ext.)	VCC: 12 ... 24 V DC \pm 20% I: 102 ... 205 mA
Power over Ethernet	Class 1 device VCC: 36 ... 57 V DC I: 63 mA @ 48 VDC
Power Consumption	approx. 2.5 W @ 12VDC and 94 fps approx. 3.0 W @ 48 VDC (PoE) and 94 fps (Factory Setting "Default")
Digital Input	Optocoupler $U_{IN(low)}$: 0.0 ... 4.5 VDC $U_{IN(high)}$: 11.0 ... 30.0 VDC I_{IN} : 3.0 ... 10.0 mA min. Impulse Length: 2.0 μ sec
Digital Output	Optocoupler U_{EXT} : 5 ... 30 V DC I_{OUT} : max. 50 mA t_{ON} = typ. 3 μ sec t_{OFF} = typ. 40 μ sec
GPIO	direct, without optocoupler
GPIO used as Input:	$U_{IN(low)}$: 0.0 ... 0.8 VDC $U_{IN(high)}$: 2.0 ... 30.0 VDC min. Impulse Length: 2.0 μ sec
GPIO used as Output:	$U_{Out(low)}$: 0.0 ... 0.4 VDC ($I_{sink\ max}$: 50 mA) $U_{Out(high)}$: 2.4 ... 3.3VDC (I_{max} : 1 mA)
Caution 	* The General Purpose I/Os (GPIOs) are not potential-free and do not have an overrun cut-off. Incorrect wiring (overvoltage, undervoltage or voltage reversal) can lead to defects in the electronic system. Ground loops are to be avoided and can lead to destruction of the device.

Conformity

Conformity	CE, RoHS, REACH, KC, EAC
KC Registration No. / Date	MSIP-REI-BkR-VCXG-13M / 02.05.2017
MTBF	63 years @ T = 45 °C / 40 years @ T = 60 °C T = Measurement Point

GenICam™ Features

Short Exposure Range	-
Timer	Timer Selector: Timer 1 TimerTriggerSource: Action 1, ExposureEnd, ExposureStart, FrameTransferSkipped, Line0, Software, TriggerSkipped and Off TimerDelay: 0 μ sec ... 2 sec, Step Size: 1 μ sec TimerDuration: 4 μ sec ... 2 sec, Step Size: 1 μ sec
Counter	Counter Selector: Counter 1, Counter 2 CounterValue: 0 ... 65535 Counter Event Source: Counter1End or Counter2End, ExposureActive, FrameTransferSkipped, FrameTrigger, TriggerSkipped, Line0..2 and Off Counter Reset Source: Counter1End, Counter2End, Line0..2 and Off
Sequencer	Sequencer Characteristics: up to 128 sets, up to 4 possible pathes for triggered set transitions, 6 trigger sources: Counter1End, Counter2End, ExposureActive, Line0..2, ReadoutActive, Timer1End Sequencer Parameters for Exposure, Gain, Trigger, ROI and Output: ExposureTime, CounterDuration, CounterEventActivation, CounterEventSource, CounterResetSource, ExposureMode, ExposureTime, Gain, Height, OffsetX, OffsetY, TriggerMode, UserOutputValue, UserOutputValueAll, Width

GenICam™ Features

User Sets	Factory Settings: UserSet0 (read only) Freely Programmable: UserSet1, UserSet2, UserSet3 Parameters: any user definable Parameter
Acquisition Abort	Delay up to 6.9 msec
Chunk Data	yes, Chunk Selector: Binning, BlackLevel, CounterValue, DeviceTemperature, ExposureTime, FrameID, Gain, Height, Image, ImageControl, LineStatusAll, OffsetX, OffsetY, PixelFormat, SequencerSetActive, Timestamp, Width
Device Temperature	InHouse Event generation for Normal to High, High to Exceeded and Exceeded to Normal Exceeded (no image transfer) = max. internal temperature sensor + 1 °C
Device Link Throughput Limit	yes, up to max. Device Link Speed
Custom Data	yes, 128 Byte with CustomDataKonfiguration Mode
SFNC Version	v2.4

Factory Settings after Start-Up

Ethernet IP Configuration	
Trigger Mode	Off (Free Running)
Analog Controls	Exposure Time: 4 msec, Gain: 0 dB, Offset: 0
Pixel Format	Mono8
Partial Scan	Off
Acquisition Frame Rate	Off
Timer/Counter/Sequencer	Off
Defect Pixel Correction	ON
Fixed Pattern Noise Correction	ON
Digital Input	Line0, invert = false
Digital Output	Line3, invert = false, line source = Off
GPIO 1/2	Line1, Line2, invert = false, LineMode = Input
TriggerSource	All

Partial Scan @ FullFrame, min Exposure, Mono8 (monochrome camera) or BayerRG8 (color camera)

	Resolution	max. fps acquisition	max. fps interface ²⁾
SXGA	1280 x 1024	146	94
HD720	1280 x 720	206	133
XGA	1024 x 768	240	156
SVGA	800 x 600	382	256
VGA	640 x 480	573	401
CIF	352 x 288	1431	1214
QVGA	320 x 240	1748	1601
QCIF	176 x 144	2433	2433
LineScan	1280 x 1024	146	94
	1280 x 512	286	188
	1280 x 256	546	376
	1280 x 128	1000	751
	1280 x 64	1710	1501
	1280 x 32	2650	2650
	1280 x 16	3654	3654
	1280 x 8	4508	4508
	1280 x 4	5105	5105
	1280 x 2	5467	5467
	1280 x 1	5668	5668

²⁾ depends on the used interface