



Device Information

Model Name	VCXG.2-51MP
Vendor Name	Baumer

Sensor Information

Sensor Name	Sony IMX264 Gen2
Type	2/3" progressive scan CMOS
Shutter	Global Shutter
Resolution	2448 x 2048 pixels
Scan Area	8.44 mm x 7.06 mm
Pixel Size	3.45 μm x 3.45 μm

Data Quality

@ 20 °C, gain = 1, exposure time = 4 msec

Dark Noise (σ)	2 e- typical
Saturation	9300 e- typical
Dynamic Range	71 dB typical
SNR	40 dB typical
Quantum efficiency η	25% @ 536 nm typical

Acquisition

Resolution	2448 px x 2048 px		
Interface Frame Rate (depends on used interface performance)	Format	Resolution	max. Frame Rate (@ Trigger Mode) ²⁾
	Full Frame	2448 x 2048	24 fps
	Binning 2x2	1224 x 1024	35 fps
	Binning 2x1	1224 x 2048	35 fps
	Binning 1x2	2448 x 1024	35 fps

Acquisition Frame Rate¹⁾ 35 fps | $t_{\text{readout}} = 27.9 \text{ msec}$ (max. Res. Full Frame) @ 12 bit (Burst Mode)

Pixel Formats	Mono8, Mono10, Mono12, Mono12p
Partial Scan	True Partial Scan with increasing Frame Rate on Y direction, Region of Interest (ROI) arbitrary Width: minimum 16, increment 16 Height: minimum 1, increment 1
Adjustable Acquisition Frame Rate	Off or 0.01 ... 65535 Hz
Acquisition Mode	Continuous, Single Frame and Multi Frame
Acquisition Status	AcquisitionActive, AcquisitionTrigger Wait
Exposure Mode	Timed
Shutter Mode	Global
Readout Mode	Sequential

Image Pre-Processing

Analog Controls	Exposure Time (1 μsec ... 60 sec Step Size 1 μsec) Gain (0...48 dB), Offset (0 ... 255 LSB 12 bit)
Auto Function	-
LUT	Luminance (12 bit)
Color Models	Mono
Color Processing	-
Color Adjustment	-

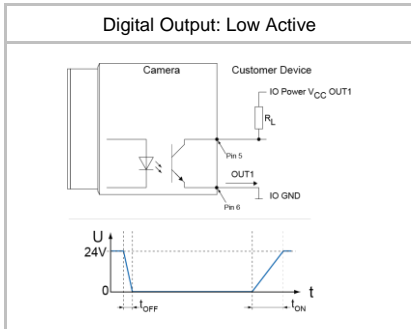
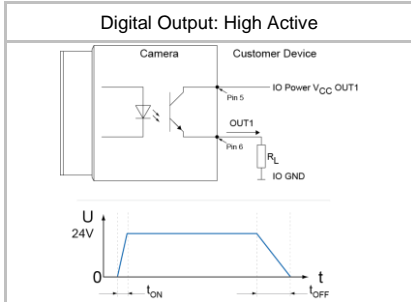
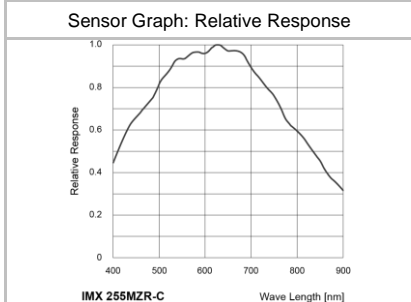

¹⁾ Sensor readout, different from pixel format

²⁾ depends on the used interface

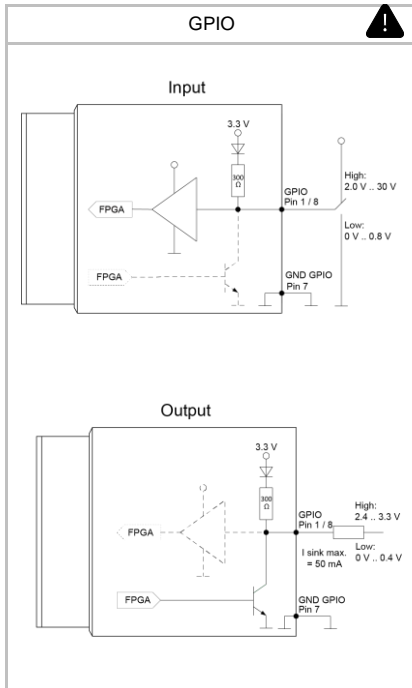
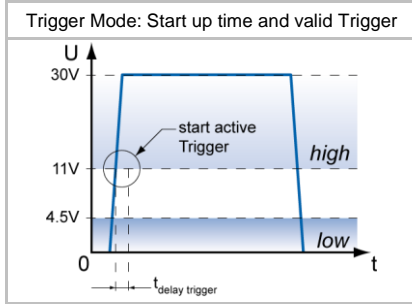
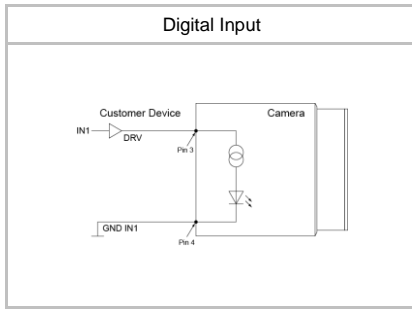

Image Pre-Processing

Color Enhancement	-
Color Tolerance	-
Binning Horizontal	1 or 2
Binning Vertical	1 or 2
Defect Pixel Correction	via Defect Pixel List with up to 512 Pixel Coordinates
Image Flipping	Horizontal, vertical
Fix Pattern Noise Correction	-

Process Synchronization

Trigger Mode	Off (Free Running), On (Trigger)
Trigger Overlap Type	Readout
Trigger Sources	Hardware (Line0, 1, 2), Software, Counter 1, 2 End, Action CMD (Action 1), All or Off fixed Trigger Delay out of $t_{readout}$: ¹⁾ 32 μ sec @ 12 bit max. Trigger Delay during $t_{readout}$: ¹⁾ 40.3 μ sec @ 12 bit
Trigger Delay	0 ... 2 sec, Tracking and buffering of up to 256 triggers
External Flash Sync	via Exposure Active $t_{delay flash} \leq 3 \mu$ sec, $t_{duration} = t_{exposure}$
Encoder Function	yes, via Counter and Trigger Source
PTP Function	-

Digital I/Os

Lines	Input: Line 0, Output: Line3, GPIO: Line 1, Line 2
Line Sources (Output)	Off, ExposureActive, Timer1, ReadoutActive, UserOutput 1-3 and TriggerReady
Line Debouncer (Input)	Low and high signal separately selectable Debouncing Time 0 ... 5 msec, Step Size: 1 μ sec

Memory

Image Buffer	115 MB 8 Images (Trigger Mode) / 1 Image (Free Running Mode)
Non-volatile Memory	128 kb

Network Interface Data

Interface	Gigabit Ethernet 1000BASE-T 1000 Mbts/sec Fast Ethernet 100 BASE-T 100 Mbts/sec
Ethernet IP Configuration	Persistent IP, DHCP, LLA
Packet Size	576 ... 9000 Byte, Jumbo Frames supported

GigE Vision® Features

Events	DeviceTemperatureStatusChanged, EventLost, ExposureEnd, ExposureStart, FrameEnd, FrameStart, FrameTransferSkipped, GigE VisionError, GigE VisionHeartbeatTimeOut, PrimaryApplicationSwitch, Line0..2 FallingEdge, Line0..2 RisingEdge, TransferBufferFull, TransferBufferReady, TriggerOverlapped, TriggerReady, TriggerSkipped
Transmission via Asynchronous Message Channel	
Action CMD	yes, Action 1 for Trigger
Frame Counter	up to 2^{32}
Payload Size	0 ... 10027232 Byte
Timestamp	64 bit, resolution in nsec, increment = 8
Packet Delay	0 .. 2^{32} - 1 nsec
Packet Resend	Resend Buffer: 77 MB (8 Images)
GigE Vision	v2.0

¹⁾ Sensor readout, different from pixel format

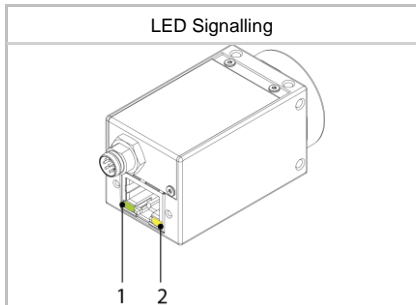
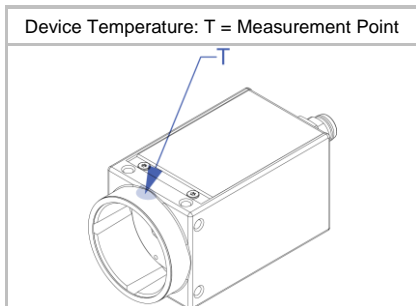
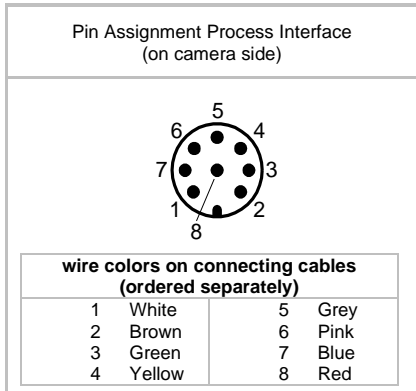
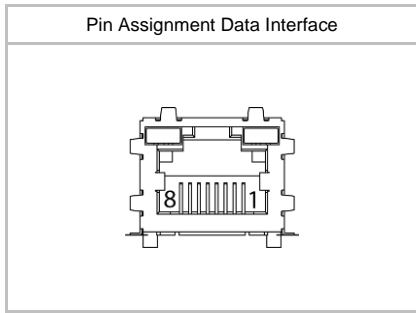

Interfaces and Connectors

Data and Power Interface	Gigabit Ethernet	Transfer Rate	1000 Mbits/sec
	Fast Ethernet	Transfer Rate	100 Mbits/sec
	Connector:	8P8C Modular Jack (RJ45), screw lock type	
Process Interface	Assignment:	1 - MX1+	2 - MX1-
		3 - MX2+	4 - MX3+
		5 - MX3-	6 - MX2-
		7 - MX4+	8 - MX4-
	Connector:	M8/8-pin (SACC-DSI-M8MS-8CON-M8-L180)	
	Assignment:	1 - GPIO (Line2)	2 - Power Vcc
		3 - IN1 (Line0)	4 - GND IN1
	5 - Power VCC OUT	6 - OUT1 (Line3)	
	7 - GND (Power, GPIO)	8 - GPIO (Line1)	

Caution * Note GPIOs: Ground loops are to be avoided and can lead to destruction of the device.

Optical Data

Lens Mount	C-Mount
Optical Filter	-

Mechanical Data

Housing	Zinc die casting, baked varnish
Protection Class	IP40 (with mounted lens and GigE cable)
Weight	120 g

Dimensions

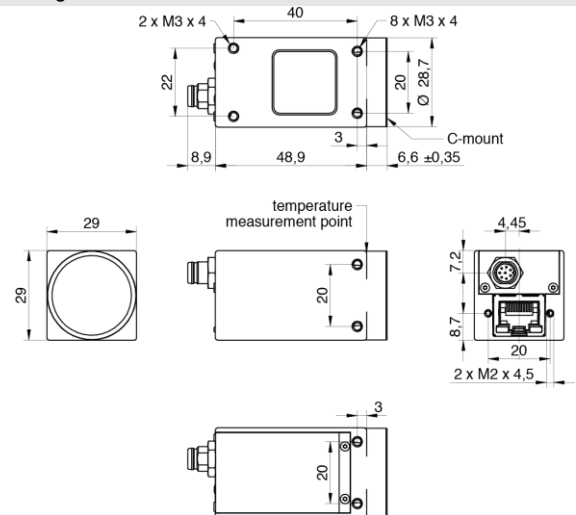

Additional Cooling Pipe	no
-------------------------	----

Environmental Data

Storage Temperature	-20 °C ... +70 °C
Operating Temperature	0 °C ... +65 °C @ T = Measurement Point or 0 °C ... +75 °C @ internal Temperature Sensor
	Note: Ambient temperature above 32 °C requires heat dissipation measures.
Int. Temperature	yes, accuracy:
Sensor	±1 °C (typ) 0 °C ... +85 °C
Humidity	10 % ... 90 % non-condensing

¹⁾ the maximum temperature for Sony sensor characteristics (sensor performance) are guaranteed up to 49 °C @ Measurement Point or up to 60 °C @ internal temperature sensor

LED Signalling

LED	LED 1	Green static Green flash	Link ON RX active
	LED 2	Yellow static Yellow flash	Error TX active

Electrical Data

Power Supply (ext.)	VCC: 12 ... 24 V DC \pm 20% I: 116 ... 234 mA
Power over Ethernet	Class 1 device VCC: 36 ... 57 V DC I: 73 mA @ 48 VDC
Power Consumption	approx. 2.8 W @ 12 VDC and 24 fps approx. 3.5 W @ 48 VDC (PoE) and 24 fps (Factory Setting "Default")
Digital Input	Optocoupler $U_{IN(low)}$: 0.0 ... 4.5 VDC $U_{IN(high)}$: 11.0 ... 30.0 VDC I_{IN} : 3.0 ... 10.0 mA min. Impulse Length: 2.0 μ sec
Digital Output	Optocoupler U_{EXT} : 5 ... 30 V DC I_{OUT} : max. 50 mA t_{ON} = typ. 3 μ sec t_{OFF} = typ. 40 μ sec
GPIO	direct, without optocoupler
GPIO used as Input:	$U_{IN(low)}$: 0.0 ... 0.8 VDC $U_{IN(high)}$: 2.0 ... 30.0 VDC min. Impulse Length: 2.0 μ sec
GPIO used as Output:	$U_{Out(low)}$: 0.0 ... 0.4 VDC ($I_{sink\ max}$: 50 mA) $U_{Out(high)}$: 2.4 ... 3.3VDC (I_{max} : 1 mA)
Caution 	* The General Purpose I/Os (GPIOs) are not potential-free and do not have an overrun cut-off. Incorrect wiring (overvoltage, undervoltage or voltage reversal) can lead to defects in the electronic system. Ground loops are to be avoided and can lead to destruction of the device.

Conformity

Conformity	CE, RoHS, REACH
KC Registration No. / Date	- / -
MTBF	51 years @ T = 45 °C / 33 years @ T = 60 °C T = Measurement Point

GeniCam™ Features

Short Exposure Range	yes, ShortExposureTimeEnable Short Exposure Range 1 μ sec ... 60 sec Default Exposure Range 15 μ sec ... 60 sec
Timer	Timer Selector: Timer 1 TimerTriggerSource: Line0, SoftwareTrigger, ExposureStart, ExposureEnd, FrameTransferSkipped, TriggerSkipped, Action 1 and Off TimerDelay: 0 μ sec ... 2 sec, Step Size: 1 μ sec TimerDuration: 4 μ sec ... 2 sec, Step Size: 1 μ sec
Counter	Counter Selector: Counter 1, Counter 2 CounterValue: 0 ... 65535 Counter Event Source: Counter1End or Counter2End, ExposureActive, FrameTransferSkipped, FrameTrigger, TriggerSkipped, Line0..2 and Off Counter Reset Source: Counter1End, Counter2End, Line0..2 and Off

GenICam™ Features

Sequencer	Sequencer Characteristics: up to 128 sets, up to 4 possible paths for triggered set transitions, 6 trigger sources: Counter1End, Counter2End, ExposureActive, Line0..2, ReadoutActive, Timer1End Sequencer Parameters for Exposure, Gain, Trigger, ROI and Output: ExposureTime, CounterDuration, CounterEventActivation, CounterEventSource, CounterResetSource, ExposureMode, ExposureTime, Gain, Height, OffsetX, OffsetY, TriggerMode, UserOutputValue, UserOutputValueAll, Width
User Sets	Factory Settings: UserSet0 (read only) Freely Programmable: UserSet1, UserSet2, UserSet3 Parameters: any user definable Parameter
Acquisition Abort	Delay up to 27.9 msec
Chunk Data	yes, Chunk Selector: Binning, BlackLevel, CounterValue, DeviceTemperature, ExposureTime, FrameID, Gain, Height, Image, ImageControl, LineStatusAll, OffsetX, OffsetY, PixelFormat, SequencerSetActive, Timestamp, Width
Device Temperature	InHouse Event generation for Normal to High, High to Exceeded and Exceeded to Normal Exceeded (no image transfer) = max. internal temperature sensor + 1 °C
Device Link Throughput Limit	yes, up to max. Device Link Speed
Custom Data	yes, 128 Byte with CustomDataKonfiguration Mode
Calibration Data	yes, camera calibration values can stored: CalibrationMatrix, CalibrationMatrixNew, CalibrationFocalLenght, CalibrationAngularAperture, GeometryDistortionValue: k1, k2, p1, p2, k3, CalibrationVector: tvec, rvec and CalibrationDataVersion
SFNC Version	2.4.0

Factory Settings after Start-Up

Ethernet IP Configuration	DHCP, LLA
Trigger Mode	Off (Free Running)
Analog Controls	Exposure Time: 4 msec, Gain: 0 dB, Offset: 0
Pixel Format	Mono8
Partial Scan	Off
Acquisition Frame Rate	Off
Timer/Counter/Sequencer	Off
Defect Pixel Correction	On
Fixed Pattern Noise Correction	-
Digital Input	Line0, invert = false
Digital Output	Line3, invert = false, line source = Off
GPIO 1/2	Line1, Line2, invert = false, LineMode = Input
TriggerSource	All

Partial Scan @ FullFrame, min Exposure, Mono8 (monochrome camera) or BayerRG8 (color camera)

	Resolution	max. fps acquisition	max. fps interface ²⁾
Full HD	1920 x 1080	66	59
SXGA	1280 x 1024	69	69
HD720	1280 x 720	97	97
XGA	1024 x 768	91	91
SVGA	800 x 600	115	115
VGA	640 x 480	140	140
CIF	352 x 288	220	220
QVGA	320 x 240	255	255
QCIF	176 x 144	379	379
LineScan	2448 x 2048	35	24
	2448 x 1024	69	49
	2448 x 512	133	98
	2448 x 256	242	196
	2448 x 128	413	393
	2448 x 64	636	636
	2448 x 32	872	872
	2448 x 16	1070	1070
	2448 x 8	1208	1208
	2448 x 4	1290	1290
	2448 x 2	1336	1336
	2448 x 1	1360	1360

²⁾ depends on the used interface