



Device Information

Model Name	VCXG.2-83UV
Vendor Name	Baumer

Sensor Information

Sensor Name	Sony IMX487 Gen4
Type	2/3" progressive scan CMOS
Shutter	Global Shutter
Resolution	2848 x 2832 pixels
Scan Area	7.8 mm x 7.75 mm
Pixel Size	2.74 μm x 2.74 μm

Data Quality

@ 20 °C, gain = 1, exposure time = 4 msec

Dark Noise (σ)	2.5 e- typical
Saturation	9000 e- typical
Dynamic Range	70 dB typical
SNR	40 dB typical
Quantum efficiency η	53% @ 536 nm typical

Acquisition

Resolution	2848 px x 2832 px		
Interface Frame Rate (depends on used interface performance)	Format	Resolution	max. Frame Rate (@ Trigger Mode) ²⁾
	Full Frame	2848 x 2832	15 fps
	Binning 2x2	1424 x 1416	59 fps
	Binning 2x1	1424 x 2832	16 fps
	Binning 1x2	2848 x 1416	16 fps
Acquisition Frame Rate ¹⁾ (Burst Mode)	16 fps t _{readout} = 60.7 msec (max. Res. Full Frame) @ 12 bit		
	58 fps t _{readout} = 17.1 msec (max. Res. Binning 2x2) @ 12 bit		
Pixel Formats	Mono8, Mono10, Mono12, Mono12p		
Partial Scan	True Partial Scan with increasing Frame Rate on Y direction, Region of Interest (ROI) arbitrary Width: minimum 32, increment 32 Height: minimum 1, increment 1		
Adjustable Acquisition Frame Rate	Off or 0,01 ... 65535 Hz		
Acquisition Mode	Continuous, Single Frame and Multi Frame		
Acquisition Status	AcquisitionActive, AcquisitionTrigger Wait		
Exposure Mode	Timed		
Shutter Mode	Global		
Readout Mode	Sequential		

Sensor Graph: Relative Response

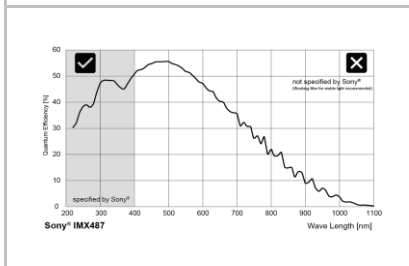

Digital Output: High Active

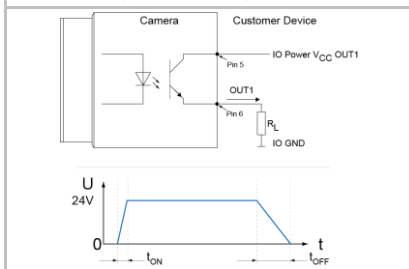

Digital Output: Low Active

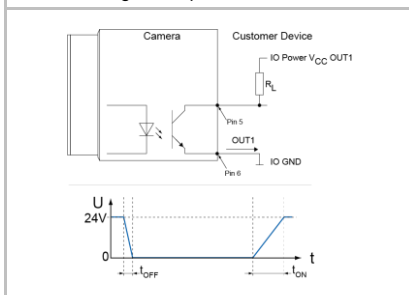

¹⁾ Sensor readout, different from pixel format

²⁾ depends on the used interface

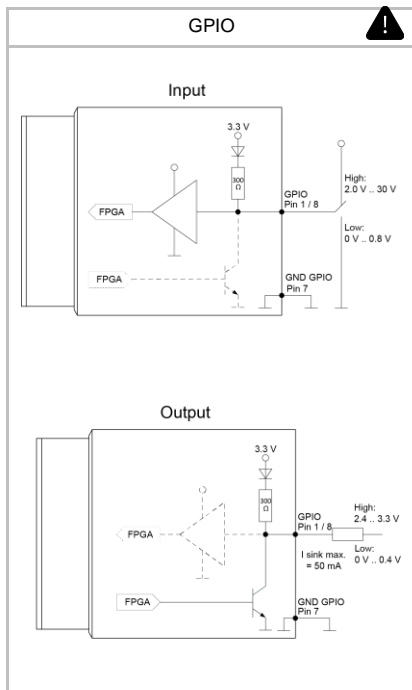
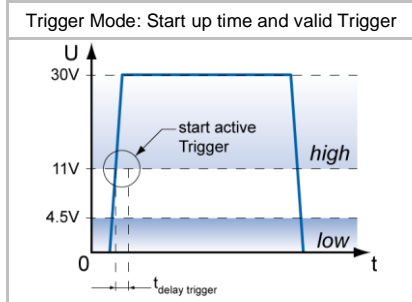
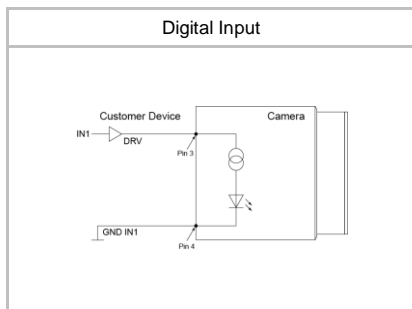

Image Pre-Processing

Color Enhancement	-
Color Tolerance	-
Binning Horizontal	1 or 2
Binning Vertical	1 or 2
Defect Pixel Correction	yes, static DPC: Defect Pixel List with up to 512 Pixel Coordinates
Image Flipping	Horizontal, vertical
Fix Pattern Noise Correction	-

Process Synchronization

Trigger Mode	Off (Free Running), On (Trigger)
Trigger Overlap Type	Readout
Trigger Sources	Hardware (Line0, 1, 2), Software, Counter 1, 2 End, Action CMD (Action 1), All or Off fixed Trigger Delay out of treadout: ¹⁾ 324 µsec @ 12 bit max. Trigger Delay during treadout: ¹⁾ 324 µsec @ 12 bit
Trigger Delay	0 ... 2 sec, Tracking and buffering of up to 256 triggers
External Flash Sync	via Exposure Active $t_{\text{delay flash}} \leq 3 \mu\text{sec}$, $t_{\text{duration}} = t_{\text{exposure}}$
Encoder Function	yes, via Counter and Trigger Source
PTP Function	-

Digital I/Os

Lines	Input: Line 0, Output: Line3, GPIO: Line 1, Line 2
Line Sources (Output)	Off, ExposureActive, Timer1, ReadoutActive, UserOutput 1-3 and TriggerReady
Line Debouncer (Input)	Low and high signal separately selectable Debouncing Time 0 ... 5 msec, Step Size: 1 µsec

Memory

Image Buffer	124 MB 8 Images (Trigger Mode) / 1 Image (Free Running Mode)
Non-volatile Memory	128 kb

Network Interface Data

Interface	Gigabit Ethernet 1000BASE-T 1000 Mbits/sec Fast Ethernet 100 BASE-T 100 Mbits/sec
Ethernet IP Configuration	Persistent IP, DHCP, LLA
Packet Size	576 ... 9000 Byte, Jumbo Frames supported

GigE Vision® Features

Events	DeviceTemperatureStatusChanged, EventLost, ExposureEnd, ExposureStart, FrameEnd, FrameStart, FrameTransferSkipped, GigEVisionError, GigEVisionHeartbeatTimeOut, PrimaryApplicationSwitch, Line0..2 FallingEdge, Line0..2 RisingEdge, TransferBufferFull, TransferBufferReady, TriggerOverlapped, TriggerReady, TriggerSkipped
Transmission via Asynchronous Message Channel	
Action CMD	yes, Action 1 for Trigger
Frame Counter	up to 2 ³²
Payload Size	0 ... 16131296 Byte
Timestamp	64 bit, resolution in nsec, increment = 8
Packet Delay	0 .. 2 ³² - 1 nsec
Packet Resend	Resend Buffer: 124 MB (8 Images)
GigE Vision	v2.0

¹⁾ Sensor readout, different from pixel format

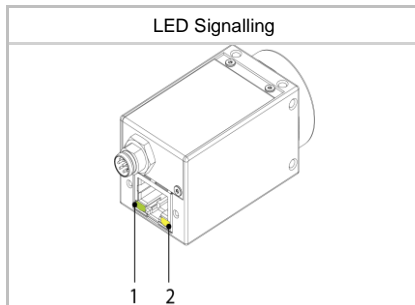
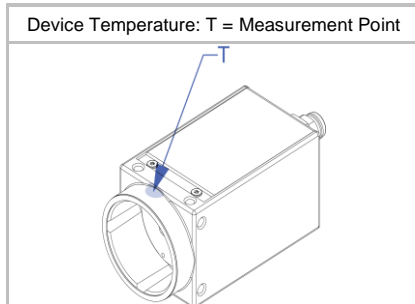
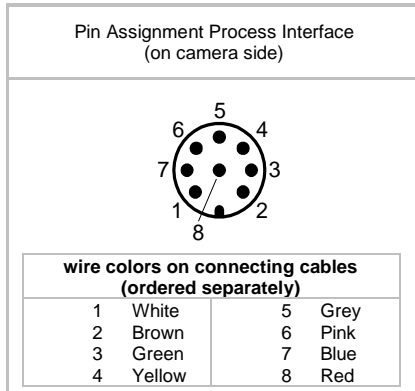
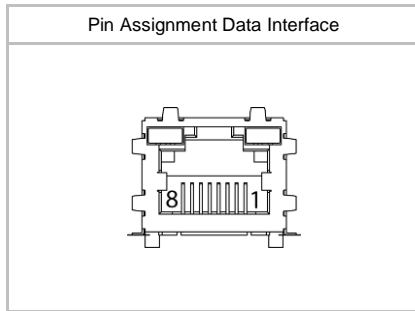

Interfaces and Connectors

Data and Power Interface	Gigabit Ethernet	Transfer Rate	1000 Mbits/sec
	Fast Ethernet	Transfer Rate	100 Mbits/sec
Connector: 8P8C Modular Jack (RJ45), screwable TYPE090 (according to GigE Vision Mechanical Supplement)			
Assignment:	1 - MX1+	2 - MX1-	
	3 - MX2+	4 - MX3+	
	5 - MX3-	6 - MX2-	
	7 - MX4+	8 - MX4-	

Process Interface	Connector:	M8/8-pin (SACC-DSI-M8MS-8CON-M8-L180)
Assignment:	1 - GPIO (Line2)	2 - Power Vcc
	3 - IN1 (Line0)	4 - GND IN1
	5 - Power VCC OUT	6 - OUT1 (Line3)
	7 - GND (Power, GPIO)	8 - GPIO (Line1)

Caution



* Note GPIOs: Ground loops are to be avoided and can lead to destruction of the device.

Optical Data

Lens Mount	C-Mount
Optical Filter	-

Mechanical Data

Housing	Zinc die casting, baked varnish
Protection Class	IP40 (with mounted lens and GigE cable)
Weight	120 g

Dimensions

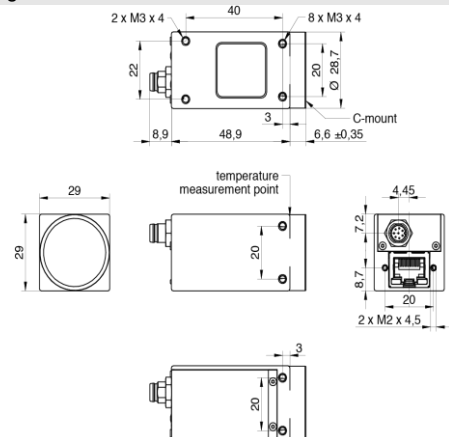

Additional Cooling Pipe	no
-------------------------	----

Environmental Data

Storage Temperature	-20 °C ... + 70 °C
Operating Temperature	0 °C ... +65 °C @ T = Measurement Point or 0 °C ... +75 °C @ internal Temperature Sensor
	Note: Ambient temperature above 30 °C requires heat dissipation measures.
Int. Temperature Sensor	yes, InHouse: step size 0.0625 °C, accuracy ±0.5 °C (typ) 0 °C ... +85 °C, Sensor: step size 0.125 °C, accuracy not specified
Humidity	10 % ... 90 % non-condensing

¹⁾ the maximum temperature for Sony sensor characteristics (sensor performance) are guaranteed up to 50 °C @ Measurement Point or up to 60 °C @ internal temperature sensor

LED Signalling

LED	LED 1	Yellow static - Error Yellow flash - TX active
	LED 2	Green static - Link ON Green flash - RX active

Electrical Data

Power Supply (ext.)	VCC: 12 ... 24 V DC \pm 20% I: 125 ... 250 mA
Power over Ethernet	Class 2 device VCC: 36 ... 57 V DC I: 71 mA @ 48 VDC
Power Consumption	approx. 3.0 W @ 12 VDC and 15 fps approx. 3.4 W @ 48 VDC (PoE) and 15 fps (Factory Setting "Default")
Digital Input	Optocoupler $U_{IN(low)}$: 0.0 ... 4.5 VDC $U_{IN(high)}$: 11.0 ... 30.0 VDC I_{IN} : 3.0 ... 10.0 mA min. Impulse Length: 2.0 μ sec
Digital Output	Optocoupler U_{EXT} : 5 ... 30 V DC I_{OUT} : max. 50 mA t_{ON} = typ. 3 μ sec t_{OFF} = typ. 40 μ sec
GPIO	direct, without optocoupler
GPIO used as Input:	$U_{IN(low)}$: 0.0 ... 0.8 VDC $U_{IN(high)}$: 2.0 ... 30.0 VDC min. Impulse Length: 2.0 μ sec
GPIO used as Output:	$U_{Out(low)}$: 0.0 ... 0.4 VDC ($I_{sink\ max}$: 50 mA) $U_{Out(high)}$: 2.4 ... 3.3VDC (I_{max} : 1 mA)
Caution 	* The General Purpose I/Os (GPIOs) are not potential-free and do not have an overrun cut-off. Incorrect wiring (overvoltage, undervoltage or voltage reversal) can lead to defects in the electronic system. Ground loops are to be avoided and can lead to destruction of the device.

Conformity

Conformity	CE, RoHS, REACH, UL Recognized
KC Registration No. / Date	- / -
MTBF	50 years @ T = 45 °C / 32 years @ T = 60 °C T = Measurement Point

GeniCam™ Features

Short Exposure Range	yes, ShortExposureTimeEnable Short Exposure Range 1 ... 3 μ sec - 23 μ sec ... 60 sec Default Exposure Range 23 μ sec ... 60 sec
Timer	Timer Selector: Timer 1 TimerTriggerSource: Line0, SoftwareTrigger, ExposureStart, ExposureEnd, FrameTransferSkipped, TriggerSkipped, Action 1 and Off TimerDelay: 0 μ sec ... 2 sec, Step Size: 1 μ sec TimerDuration: 4 μ sec ... 2 sec, Step Size: 1 μ sec
Counter	Counter Selector: Counter 1, Counter 2 CounterValue: 0 ... 65535 Counter Event Source: Counter1End or Counter2End, ExposureActive, FrameTransferSkipped, FrameTrigger, TriggerSkipped, Line0..2 and Off Counter Reset Source: Counter1End, Counter2End, Line0..2 and Off

GenICam™ Features

Sequencer	Sequencer Characteristics: up to 128 sets, up to 4 possible pathes for triggered set transitions, 6 trigger sources: Counter1End, Counter2End, ExposureActive, Line0..2, ReadoutActive, Timer1End Sequencer Parameters for Exposure, Gain, Trigger, ROI and Output: ExposureTime, CounterDuration, CounterEventActivation, CounterEventSource, CounterResetSource, ExposureMode, ExposureTime, Gain, Height, OffsetX, OffsetY, TriggerMode, UserOutputValue, UserOutputValueAll, Width
User Sets	Factory Settings: UserSet0 (read only) Freely Programmable: UserSet1, UserSet2, UserSet3 Parameters: any user definable Parameter
Acquisition Abort	Delay up to 60.7 msec
Chunk Data	yes, Chunk Selector: Binning, BlackLevel, CounterValue, DeviceTemperature, ExposureTime, FrameID, Gain, Height, Image, ImageControl, LineStatusAll, OffsetX, OffsetY, PixelFormat, SequencerSetActive, Timestamp, Width
Device Temperature	InHouse and Sensor InHouse: Event generation, if temperature status changed from Normal to High, High to Exceeded and Exceeded to Normal Exceeded (no image transfer) = max. internal temperature sensor + 1 °C
Device Link Throughput Limit	yes, up to max. Device Link Speed
Custom Data	yes, 128 Byte with CustomDataKonfiguration Mode
Optical Black Pixel Area	-
Black Level Auto Adjust	-
Calibration Data	yes, camera calibration values can stored: CalibrationMatrix, CalibrationMatrixNew, CalibrationFocallenght, CalibrationAngularAperture, GeometryDistortionValue: k1, k2, p1, p2, k3, CalibrationVector: tvec, rvec and CalibrationDataVersion
SFNC Version	2.4.0

Factory Settings after Start-Up

Ethernet IP Configuration	DHCP, LLA
Trigger Mode	Off (Free Running)
Analog Controls	Exposure Time: 4 msec, Gain: 0 dB, Offset: 0
Pixel Format	Mono8
Partial Scan	Off
Acquisition Frame Rate	Off
Timer/Counter/Sequencer	Off
Defect Pixel Correction	On
Fixed Pattern Noise Correction	-
Optical Black Pixel Area	-
Black Level Auto Adjust	-
Digital Input	Line0, invert = false
Digital Output	Line3, invert = false, line source = Off
GPIO 1/2	Line1, Line2, invert = false, LineMode = Input
TriggerSource	All

Partial Scan @ FullFrame, min Exposure, Mono8 (monochrome camera) or BayerRG8 (color camera)

	Resolution	max. fps acquisition	max. fps interface ²⁾
Full HD	1920 x 1080	39	39
SXGA	1280 x 1024	41	41
HD720	1280 x 720	56	56
XGA	1024 x 768	53	53
SVGA	800 x 600	65	65
VGA	640 x 480	78	78
CIF	352 x 288	113	113
QVGA	320 x 240	128	128
QCIF	176 x 144	171	171
Full HD	1920 x 1080	39	39
SXGA	1280 x 1024	41	41
HD720	1280 x 720	56	56
XGA	1024 x 768	53	53
SVGA	800 x 600	65	65
VGA	640 x 480	78	78
CIF	352 x 288	113	113
QVGA	320 x 240	128	128
QCIF	176 x 144	171	171

²⁾ depends on the used interface