



Device Information

Model Name	VCXU.2-13M
Vendor Name	Baumer

Sensor Information

Sensor Name	ON Semiconductor PYTHON1300
Type	1/2" progressive scan CMOS
Shutter	Global Shutter
Resolution	1280 x 1024 pixels
Scan Area	6.14 mm x 4.91 mm
Pixel Size	4.8 μm x 4.8 μm

Data Quality

@ 20 °C, gain = 1, exposure time = 4 msec

Dark Noise (σ)	10 e- typical
Saturation	7000 e- typical
Dynamic Range	56.5 dB typical
SNR	38.5 dB typical
Quantum efficiency η	56% @ 536 nm typical

Sensor Graph: Relative Response

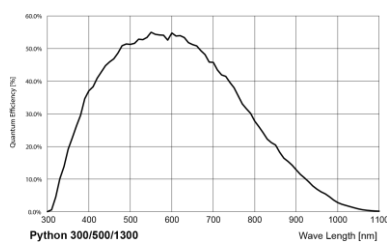

Digital Output: High Active

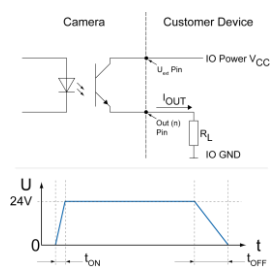

Acquisition

Resolution	1280 px x 1024 px		
Interface Frame Rate (depends on used interface performance)	Format	Resolution	max. Frame Rate (@ Trigger Mode) ²⁾
	Full Frame	1280 x 1024	222 fps
	Binning 2x2	640 x 512	222 fps
	Binning 2x1	640 x 1024	222 fps
	Binning 1x2	1280 x 512	222 fps

Acquisition Frame Rate¹⁾ 222 fps | $t_{\text{readout}} = 4.5 \text{ msec}$ (max. Res. Full Frame) @ 10 bit

Pixel Formats	Mono8, Mono10
Partial Scan	True Partial Scan with increasing Frame Rate on X and Y direction, Region of Interest (ROI) arbitrary Width: minimum 32, increment 16 Height: minimum 1, increment 1
Adjustable Acquisition Frame Rate	Off or 0.01 ... 65535 Hz
Acquisition Mode	Continuous, Single Frame and Multi Frame
Acquisition Status	AcquisitionActive, AcquisitionTrigger Wait
Exposure Mode	Timed
Shutter Mode	Global
Readout Mode	Overlapped, Sequential

Image Pre-Processing

Analog Controls	Exposure Time (20 μsec ... 1 sec Step Size 1 μsec) Gain (0...18 dB), Offset (0 ... 63 LSB 10 bit)
Auto Function	ExposureAuto and GainAuto with BrightnessAutoPriority based on BrightnessAuto ROI
Gamma Correction	Gamma (0.1 ... 2 available if LUT is enabled)
LUT	Luminance (12 bit)
Color Models	Mono
Color Processing	-
Color Enhancement	-

¹⁾ Sensor readout, different from pixel format

²⁾ depends on the used interface

Digital Output: Low Active

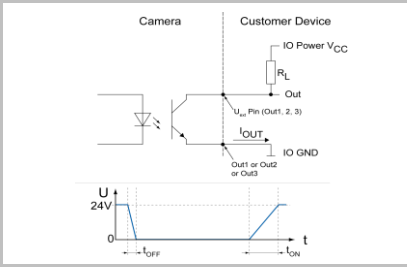

Digital Input

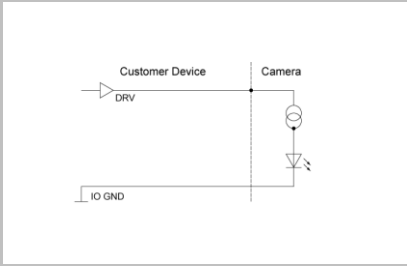

Trigger Mode: Start up time and valid Trigger

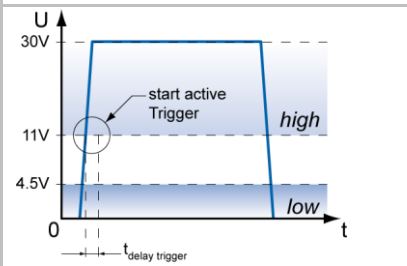

GPIO

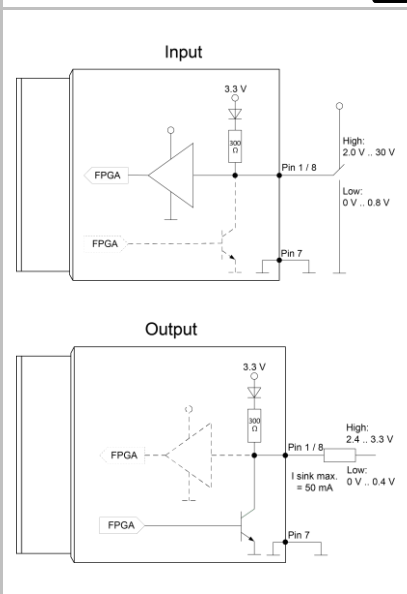

Image Pre-Processing

Color Tolerance	-
Binning Horizontal	1 or 2
Binning Vertical	1 or 2
Defect Pixel Correction	via Defect Pixel List with up to 512 Pixel Coordinates
Image Flipping	Horizontal, vertical
Fix Pattern Noise	yes
Correction	

Process Synchronization

Trigger Mode	Off (Free Running), On (Trigger)
Trigger Overlap Type	Readout
Trigger Sources	Hardware (Line0, 1, 2), Software, Counter 1, 2 End, All or Off fixed Trigger Delay out of treadout: ¹⁾ 4 µsec @ 10 bit max. Trigger Delay during treadout: ¹⁾ 8 µsec @ 10 bit
Trigger Delay	0 ... 2 sec, Tracking and buffering of up to 256 triggers
External Flash Sync	via Exposure Active $t_{\text{delay flash}} \leq 3 \mu\text{sec}$, $t_{\text{duration}} = t_{\text{exposure}}$
Encoder Function	yes, via Counter and Trigger Source
PTP Function	-

Digital I/Os

Lines	Input: Line 0, Output: Line3, GPIO: Line 1, Line 2
Line Sources (Output)	Off, ExposureActive, Timer1, ReadoutActive, UserOutput 1-3 and TriggerReady
Line Debouncer (Input)	Low and high signal separately selectable Debouncing Time 0 ... 5 msec, Step Size: 1 µsec

Memory

Image Buffer	477 MB 127 Images (Trigger Mode) / 1 Image (Free Running Mode)
Non-volatile Memory	128 kb

Interface Data

Interface	USB3.0 (5000 Mbits/sec)
USB Vendor ID / Product ID	0x2825 / 0x0171

USB 3 Vision® Features

Events Transmission via Asynchronous Message Channel	DeviceTemperatureStatusChanged, EventLost, ExposureEnd, ExposureStart, FrameEnd, FrameStart, FrameTransferSkipped, Line0..2 FallingEdge, Line0..2 RisingEdge, TransferBufferFull, TransferBufferReady, TriggerOverlapped, TriggerReady, TriggerSkipped
Frame Counter	up to 2 ³²
Payload Size	0 ... 2621664 Byte
Timestamp	64 bit, resolution in nsec, increment = 10
USB Vision	v1.0.1

Interfaces and Connectors

Data and Power Interface	USB 3.0 USB 2.0 Connector:	Transfer Rate 5000 Mbits/sec Transfer Rate 480 Mbits/sec USB 3.0 Micro B
Pin Assignment:	1 - VBUS 3 - D+ 5 - GND 7 - MicB_SSTX+ 9 - MicB_SSRX-	2 - D- 4 - ID 6 - MicB_SSTX- 8 - GND_DRAIN 10 - MicB_SSRX+

¹⁾ Sensor readout, different from pixel format

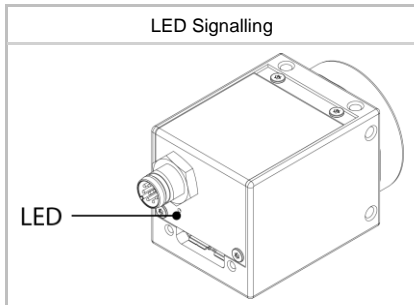
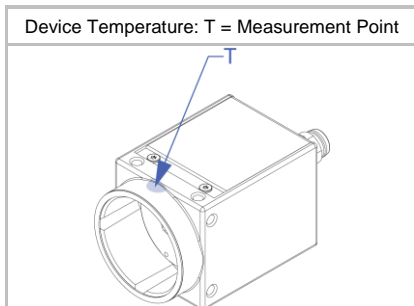
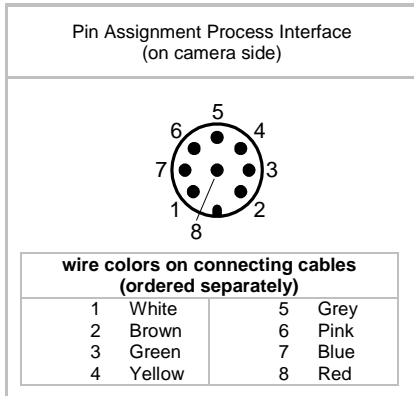
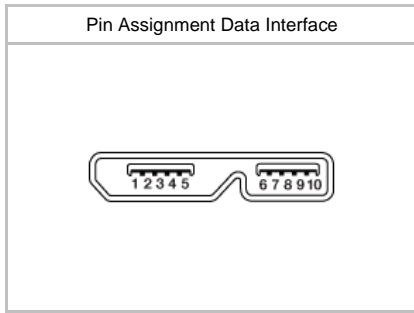

Interfaces and Connectors

Process Interface	Connector:	M8/8-pin (SACC-DSI-M8MS-8CON-M8-L180)
	Assignment:	1 - GPIO (Line2) 2 - not connected 3 - IN1 (Line0) 4 - GND IN1 5 - Power VCC 6 - OUT1 (Line3) OUT1 8 - GPIO (Line1) 7 - GND GPIO

Caution



* Note GPIOs: Ground loops are to be avoided and can lead to destruction of the device.

Optical Data

Lens Mount	C-Mount
Optical Filter	-

Mechanical Data

Housing	Zinc die casting, baked varnish
Protection Class	IP40 (with mounted lens and USB 3.0 cable)
Weight	90 g
Dimensions	

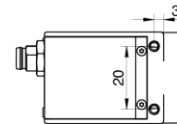
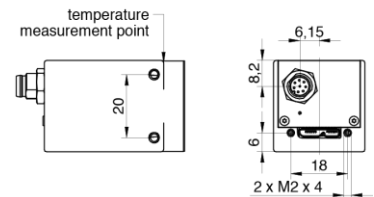
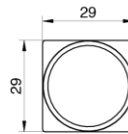
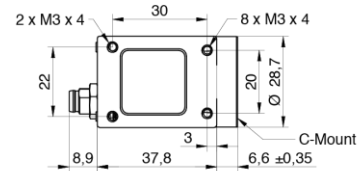

Environmental Data

Storage Temperature	-20 °C ... + 70 °C
Operating Temperature	0 °C ... +65 °C @ T = Measurement Point or 0 °C ... +75 °C @ internal Temperature Sensor Note: Ambient temperature above 30 °C requires heat dissipation measures.
Int. Temperature Sensor	yes, accuracy: ±1 °C (typ) 0 °C ... +85 °C
Humidity	10 % ... 90 % non-condensing

LED Signalling

LED	Green flash	Power on, no link active
	Green	Link active USB 3.0
	Red	Error or Link active USB 2.0
	Yellow	Sensor Readout activity
	Red flash	Update

Electrical Data

Power Supply	bus powered via USB3.0 interface
Power Consumption	approx. 2.7 W @ 222 fps (Factory Setting "Default")
Digital Input	Optocoupler $U_{IN(low)}$: 0.0 ... 4.5 VDC $U_{IN(high)}$: 11.0 ... 30.0 VDC I_{IN} : 3.0 ... 10.0 mA min. Impulse Length: 2.0 μ sec
Digital Output	Optocoupler U_{EXT} : 5 ... 30 V DC I_{OUT} : max. 50 mA t_{ON} = typ. 3 μ sec t_{OFF} = typ. 40 μ sec
GPIO	direct, without optocoupler
GPIO used as Input:	$U_{IN(low)}$: 0.0 ... 0.8 VDC $U_{IN(high)}$: 2.0 ... 30.0 VDC min. Impulse Length: 2.0 μ sec
GPIO used as Output:	$U_{Out(low)}$: 0.0 ... 0.4 VDC ($I_{sink\ max}$: 50 mA) $U_{Out(high)}$: 2.4 ... 3.3VDC (I_{max} : 1 mA)
Caution 	* The General Purpose I/Os (GPIOs) are not potential-free and do not have an overrun cut-off. Incorrect wiring (overvoltage, undervoltage or voltage reversal) can lead to defects in the electronic system. Ground loops are to be avoided and can lead to destruction of the device.

Conformity

Conformity	CE, RoHS, REACH
KC Registration No. / Date	- / -
MTBF	65 years @ T = 45 °C / 41 years @ T = 60 °C T = Measurement Point

GeniCam™ Features

Short Exposure Range	-
Timer	Timer Selector: Timer Selector: Timer 1 TimerTriggerSource: Line0, SoftwareTrigger, ExposureStart, ExposureEnd, FrameTransferSkipped, TriggerSkipped, Off TimerDelay: 0 μ sec ... 2 sec, Step Size: 1 μ sec TimerDuration: 4 μ sec ... 2 sec, Step Size: 1 μ sec
Counter	Counter Selector: Counter 1, Counter 2 CounterValue: 0 ... 65535 Counter Event Source: Counter1End or Counter2End, ExposureActive, FrameTransferSkipped, FrameTrigger, TriggerSkipped, Line0..2 and Off Counter Reset Source: Counter1End, Counter2End, Line0..2 and Off
Sequencer	Sequencer Characteristics: up to 128 sets, up to 4 possible pathes for triggered set transitions, 6 trigger sources: Counter1End, Counter2End, ExposureActive, Line0..2, ReadoutActive, Timer1End Sequencer Parameters for Exposure, Gain, Trigger, ROI and Output: ExposureTime, CounterDuration, CounterEventActivation, CounterEventSource, CounterResetSource, ExposureMode, ExposureTime, Gain, Height, OffsetX, OffsetY, TriggerMode, UserOutputValue, UserOutputValueAll, Width

GenICam™ Features

User Sets	Factory Settings: UserSet0 (read only) Freely Programmable: UserSet1, UserSet2, UserSet3 Parameters: any user definable Parameter
Acquisition Abort	Delay up to 4.5 msec
Chunk Data	yes, Chunk Selector: Binning, BlackLevel, CounterValue, DeviceTemperature, ExposureTime, FrameID, Gain, Height, Image, ImageControl, LineStatusAll, OffsetX, OffsetY, PixelFormat, SequencerSetActive, Timestamp, Width
Device Temperature	InHouse Event generation for Normal to High, High to Exceeded and Exceeded to Normal Exceeded (no image transfer) = max. internal temperature sensor + 1 °C
Device Link Throughput Limit	yes, up to max. Device Link Speed
Custom Data	yes, 128 Byte with CustomDataKonfiguration Mode
Calibration Data	yes, camera calibration values can stored: CalibrationMatrix, CalibrationMatrixNew, CalibrationFocalLenght, CalibrationAngularAperture, GeometryDistortionValue: k1, k2, p1, p2, k3, CalibrationVector: tvec, rvec and CalibrationDataVersion
SFNC Version	2.4.0

Factory Settings after Start-Up

Trigger Mode	Off (Free Running)
Analog Controls	Exposure Time: 4 msec, Gain: 0 dB, Offset: 0
Pixel Format	Mono8
Partial Scan	Off
Acquisition Frame Rate	Off
Timer/Counter/Sequencer	Off
Defect Pixel Correction	ON
Fixed Pattern Noise Correction	ON
Digital Input	Line0, invert = false
Digital Output	Line3, invert = false, line source = Off
GPIO 1/2	Line1, Line2, invert = false, LineMode = Input
TriggerSource	All

Partial Scan @ FullFrame, min Exposure, Mono8 (monochrome camera) or BayerRG8 (color camera)

	Resolution	max. fps acquisition	max. fps interface ²⁾
SXGA	1280 x 1024	222	222
HD720	1280 x 720	314	314
XGA	1024 x 768	365	365
SVGA	800 x 600	587	587
VGA	640 x 480	893	893
CIF	352 x 288	2360	2360
QVGA	320 x 240	2947	2947
QCIF	176 x 144	4310	4310
LineScan	1280 x 1024	222	222
	1280 x 512	438	438
	1280 x 256	849	849
	1280 x 128	1603	1603
	1280 x 64	2878	2878
	1280 x 32	4781	4781
	1280 x 16	7141	7141
	1280 x 8	9481	9481
	1280 x 4	11339	11339
	1280 x 2	12570	12570
	1280 x 1	13292	13292

²⁾ depends on the used interface