



Device Information

Model Name	VCXU.2-51C
Vendor Name	Baumer

Sensor Information

Sensor Name	Sony IMX264 Gen2
Type	2/3" progressive scan CMOS
Shutter	Global Shutter
Resolution	2448 x 2048 pixels
Scan Area	8.44 mm x 7.06 mm
Pixel Size	3.45 μ m x 3.45 μ m

Data Quality

@ 20 °C, gain = 1, exposure time = 4 msec

Dark Noise (σ)	2 e- typical
Saturation	9500 e- typical
Dynamic Range	71 dB typical
SNR	40 dB typical
Quantum efficiency η	48% @ 465 nm, 58% @ 536 nm, 54% @ 631 nm typical

Sensor Graph: Relative Response

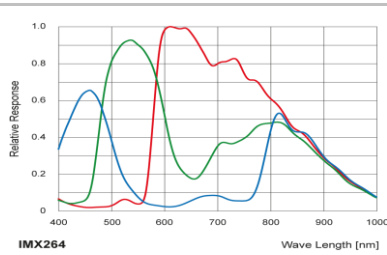

Digital Output: High Active

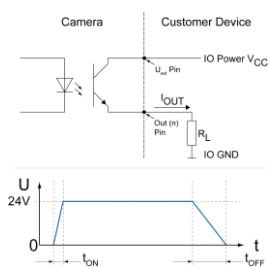

Acquisition

Resolution	2448 px x 2048 px		
Interface Frame Rate (depends on used interface performance)	Format	Resolution	max. Frame Rate (@ Trigger Mode) ²⁾
	Full Frame	2448 x 2048	35 fps
	Binning 2x2	1224 x 1024	35 fps
	Binning 2x1	1224 x 2048	35 fps
	Binning 1x2	2448 x 1024	35 fps
Acquisition Frame Rate ¹⁾	35 fps $t_{\text{readout}} = 28.3 \text{ msec}$ (max. Res. Full Frame) @ 12 bit		

Pixel Formats	BayerRG8, BayerRG10, BayerRG12, BayerRG12p, Mono8, Mono10, Mono12, Mono12p, RGB8, BGR8
Partial Scan	True Partial Scan with increasing Frame Rate on Y direction, Region of Interest (ROI) arbitrary Width: minimum 16, increment 16 Height: minimum 2, increment 2
Adjustable Acquisition Frame Rate	Off or 0.01 ... 65535 Hz
Acquisition Mode	Continuous, Single Frame and Multi Frame
Acquisition Status	AcquisitionActive, AcquisitionTrigger Wait
Exposure Mode	Timed
Shutter Mode	Global
Readout Mode	Overlapped, Sequential

Image Pre-Processing

Analog Controls	Exposure Time (1 μ sec ... 60 sec Step Size 1 μ sec) Gain (0...48 dB), Offset (0 ... 255 LSB 12 bit)
Auto Function	ExposureAuto and GainAuto with BrightnessAutoPriority based on BrightnessAuto ROI BalanceWhiteAuto and ColorTransformationAuto based on BalanceWhiteAuto ROI
Gamma Correction	Gamma (0.1 ... 2 available if LUT is enabled)
LUT	Luminance (12 bit)
Color Models	Mono, Raw Bayer, RGB and BGR
Color Processing	Integrated color processor for high quality color calculation
Color Enhancement	Color Transformation to sRGB color space by optimized Matrix for 3000 K, 5000 K, 6500 K and 9500 K Lightsource or User defined Matrix

¹⁾ Sensor readout, different from pixel format

²⁾ depends on the used interface

Digital Output: Low Active

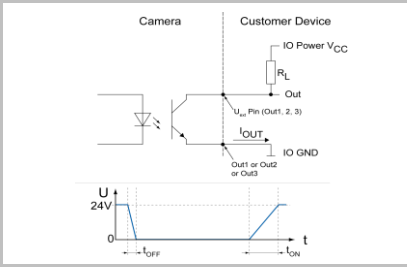

Digital Input

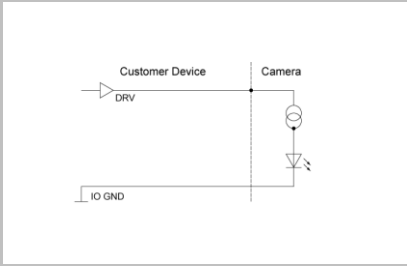

Trigger Mode: Start up time and valid Trigger

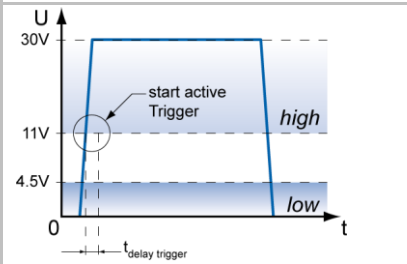

GPIO

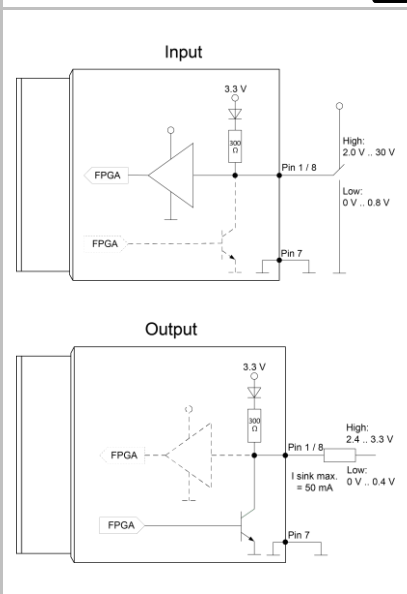

Image Pre-Processing

Color Tolerance	-
Binning Horizontal	1 or 2
Binning Vertical	1 or 2
Defect Pixel Correction	via Defect Pixel List with up to 512 Pixel Coordinates
Image Flipping	Horizontal, vertical
Fix Pattern Noise	-
Correction	-

Process Synchronization

Trigger Mode	Off (Free Running), On (Trigger)
Trigger Overlap Type	Readout
Trigger Sources	Hardware (Line0, 1, 2), Software, Counter 1, 2 End, All or Off fixed Trigger Delay out of treadout: ¹⁾ 32.5 μsec @ 12 bit max. Trigger Delay during treadout: ¹⁾ 40.4 μsec @ 12 bit
Trigger Delay	0 ... 2 sec, Tracking and buffering of up to 256 triggers
External Flash Sync	via Exposure Active $t_{\text{delay flash}} \leq 3 \mu\text{sec}$, $t_{\text{duration}} = t_{\text{exposure}}$
Encoder Function	yes, via Counter and Trigger Source
PTP Function	-

Digital I/Os

Lines	Input: Line 0, Output: Line3, GPIO: Line 1, Line 2
Line Sources (Output)	Off, ExposureActive, Timer1, ReadoutActive, UserOutput 1-3 and TriggerReady
Line Debouncer (Input)	Low and high signal separately selectable Debouncing Time 0 ... 5 msec, Step Size: 1 μsec

Memory

Image Buffer	445 MB 31 Images (Trigger Mode) / 1 Image (Free Running Mode)
Non-volatile Memory	128 kb

Interface Data

Interface	USB3.0 (5000 Mbits/sec)
USB Vendor ID / Product ID	0x2825 / 0x0171

USB 3 Vision® Features

Events	DeviceTemperatureStatusChanged, EventLost, ExposureEnd, ExposureStart, FrameEnd, FrameStart, FrameTransferSkipped, Line0..2 FallingEdge, Line0..2 RisingEdge, TransferBufferFull, TransferBufferReady, TriggerOverlapped, TriggerReady, TriggerSkipped up to 2 ³²
Transmission via Asynchronous Message Channel	
Frame Counter	up to 2 ³²
Payload Size	0 ... 15040736 Byte
Timestamp	64 bit, resolution in nsec, increment = 10
USB Vision	v1.0.1

Interfaces and Connectors

Data and Power Interface	USB 3.0	Transfer Rate	5000 Mbits/sec
	USB 2.0	Transfer Rate	480 Mbits/sec
	Connector:		USB 3.0 Micro B
Pin Assignment:	1 - VBUS	2 - D-	
	3 - D+	4 - ID	
	5 - GND	6 - MicB_SSTX-	
	7 - MicB_SSTX+	8 - GND_DRAIN	
	9 - MicB_SSRX-	10 - MicB_SSRX+	

¹⁾ Sensor readout, different from pixel format

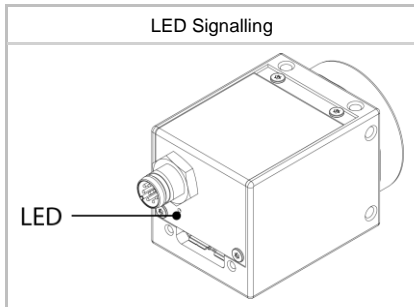
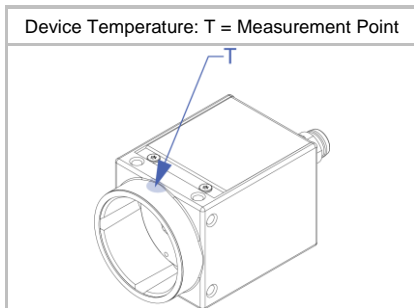
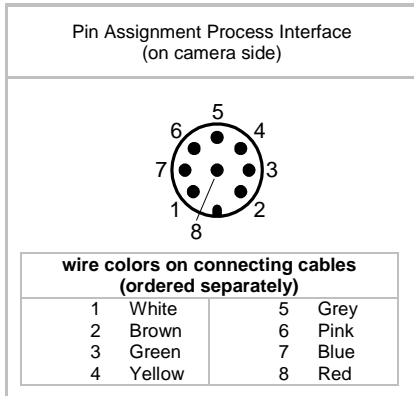
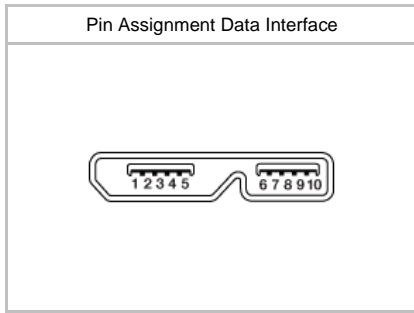

Interfaces and Connectors

Process Interface	Connector:	M8/8-pin (SACC-DSI-M8MS-8CON-M8-L180)
	Assignment:	1 - GPIO (Line2) 2 - not connected 3 - IN1 (Line0) 4 - GND IN1 5 - Power VCC 6 - OUT1 (Line3) OUT1 8 - GPIO (Line1) 7 - GND GPIO

Caution



* Note GPIOs: Ground loops are to be avoided and can lead to destruction of the device.

Optical Data

Lens Mount	C-Mount
Optical Filter	IR cut filter

Mechanical Data

Housing	Zinc die casting, baked varnish
Protection Class	IP40 (with mounted lens and USB 3.0 cable)
Weight	90 g
Dimensions	

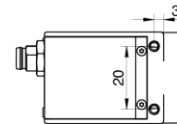
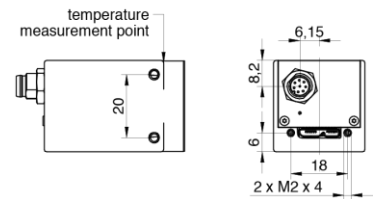
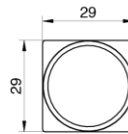
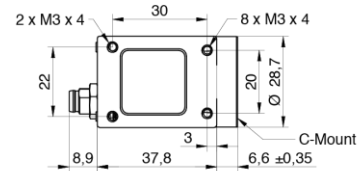

Environmental Data

Storage Temperature	-10 °C ... + 70 °C
Operating Temperature	0 °C ... +65 °C @ T = Measurement Point or 0 °C ... +72 °C @ internal Temperature Sensor Note: Ambient temperature above 35 °C requires heat dissipation measures.
Int. Temperature Sensor	yes, accuracy: ±1 °C (typ) 0 °C ... +85 °C
Humidity	10 % ... 90 % non-condensing

¹⁾ the maximum temperature for Sony sensor characteristics (sensor performance) are guaranteed up to 50 °C @ Measurement Point or up to 56 °C @ internal temperature sensor

LED Signalling

LED	Green flash	Power on, no link active
	Green	Link active USB 3.0
	Red	Error or Link active USB 2.0
	Yellow	Sensor Readout activity
	Red flash	Update

Electrical Data

Power Supply	bus powered via USB3.0 interface
Power Consumption	approx. 2.4 W @ 35 fps (Factory Setting "Default")
Digital Input	Optocoupler $U_{IN(low)}$: 0.0 ... 4.5 VDC $U_{IN(high)}$: 11.0 ... 30.0 VDC I_{IN} : 3.0 ... 10.0 mA min. Impulse Length: 2.0 μ sec
Digital Output	Optocoupler U_{EXT} : 5 ... 30 V DC I_{OUT} : max. 50 mA t_{ON} = typ. 3 μ sec t_{OFF} = typ. 40 μ sec
GPIO	direct, without optocoupler
GPIO used as Input:	$U_{IN(low)}$: 0.0 ... 0.8 VDC $U_{IN(high)}$: 2.0 ... 30.0 VDC min. Impulse Length: 2.0 μ sec
GPIO used as Output:	$U_{Out(low)}$: 0.0 ... 0.4 VDC ($I_{sink\ max}$: 50 mA) $U_{Out(high)}$: 2.4 ... 3.3VDC (I_{max} : 1 mA)
Caution 	* The General Purpose I/Os (GPIOs) are not potential-free and do not have an overrun cut-off. Incorrect wiring (overvoltage, undervoltage or voltage reversal) can lead to defects in the electronic system. Ground loops are to be avoided and can lead to destruction of the device.

Conformity

Conformity	CE, RoHS, REACH
KC Registration No. / Date	- / -
MTBF	54 years @ T = 45 °C / 34 years @ T = 60 °C T = Measurement Point

GeniCam™ Features

Short Exposure Range	yes, ShortExposureTimeEnable Short Exposure Range 1 μ sec ... 60 sec Default Exposure Range 15 μ sec ... 60 sec
Timer	Timer Selector: Timer Selector: Timer 1 TimerTriggerSource: Line0, SoftwareTrigger, ExposureStart, ExposureEnd, FrameTransferSkipped, TriggerSkipped, Off TimerDelay: 0 μ sec ... 2 sec, Step Size: 1 μ sec TimerDuration: 4 μ sec ... 2 sec, Step Size: 1 μ sec
Counter	Counter Selector: Counter 1, Counter 2 CounterValue: 0 ... 65535 Counter Event Source: Counter1End or Counter2End, ExposureActive, FrameTransferSkipped, FrameTrigger, TriggerSkipped, Line0..2 and Off Counter Reset Source: Counter1End, Counter2End, Line0..2
Sequencer	Sequencer Characteristics: up to 128 sets, up to 4 possible pathes for triggered set transitions, 6 trigger sources: Counter1End, Counter2End, ExposureActive, Line0..2, ReadoutActive, Timer1End Sequencer Parameters for Exposure, Gain, Trigger, ROI and Output: ExposureTime, CounterDuration, CounterEventActivation, CounterEventSource, CounterResetSource, ExposureMode, ExposureTime, Gain, Height, OffsetX, OffsetY, TriggerMode, UserOutputValue, UserOutputValueAll, Width

GenICam™ Features

User Sets	Factory Settings: UserSet0 (read only) Freely Programmable: UserSet1, UserSet2, UserSet3 Parameters: any user definable Parameter
Acquisition Abort	Delay up to 28.3 msec
Chunk Data	yes, Chunk Selector: Binning, BlackLevel, CounterValue, DeviceTemperature, ExposureTime, FrameID, Gain, Height, Image, ImageControl, LineStatusAll, OffsetX, OffsetY, PixelFormat, SequencerSetActive, Timestamp, Width
Device Temperature	InHouse Event generation for Normal to High, High to Exceeded and Exceeded to Normal Exceeded (no image transfer) = max. internal temperature sensor + 1 °C
Device Link Throughput Limit	yes, up to max. Device Link Speed
Custom Data	yes, 128 Byte with CustomDataKonfiguration Mode
Calibration Data	yes, camera calibration values can stored: CalibrationMatrix, CalibrationMatrixNew, CalibrationFocalLenght, CalibrationAngularAperture, GeometryDistortionValue: k1, k2, p1, p2, k3, CalibrationVector: tvec, rvec and CalibrationDataVersion
SFNC Version	2.4.0

Factory Settings after Start-Up

Trigger Mode	Off (Free Running)
Analog Controls	Exposure Time: 4 msec, Gain: 0 dB, Offset: 0
Pixel Format	BayerRG8
Partial Scan	Off
Acquisition Frame Rate	Off
Timer/Counter/Sequencer	Off
Defect Pixel Correction	ON
Fixed Pattern Noise Correction	-
Digital Input	Line0, invert = false
Digital Output	Line3, invert = false, line source = Off
GPIO 1/2	Line1, Line2, invert = false, LineMode = Input
TriggerSource	All

Partial Scan @ FullFrame, min Exposure, Mono8 (monochrome camera) or BayerRG8 (color camera)

	Resolution	max. fps acquisition	max. fps interface ²⁾
Full HD	1920 x 1080	65	65
SXGA	1280 x 1024	68	68
HD720	1280 x 720	95	95
XGA	1024 x 768	90	90
SVGA	800 x 600	113	113
VGA	640 x 480	138	138
CIF	352 x 288	215	215
QVGA	320 x 240	250	250
QCIF	176 x 144	369	369
LineScan	2448 x 2048	35	35
	2448 x 1024	68	68
	2448 x 512	130	130
	2448 x 256	237	237
	2448 x 128	401	401
	2448 x 64	613	613
	2448 x 32	833	833
	2448 x 16	1015	1015
	2448 x 8	1139	1139
	2448 x 4	1214	1214
	2448 x 2	1254	1254
	2448 x 1	-	-

²⁾ depends on the used interface