



Operating Manual

VLXT(.I) (.EF) (.JP) / VLXT.FO cameras
(10 Gigabit Ethernet)

VLXN.I.JP cameras
(5 Gigabit Ethernet)

EN-US

Table of Contents

1. General Information	10
1.1 Software Licensing Information	12
2. General safety Instructions	14
3. Camera Models	15
3.1 VLXT (.I) (.EF) (.JP) (10GBASE-T)	17
3.2 VLXN.I.JP (5GBASE-T)	21
3.3 VLXT.FO (10GBASE-SR/LR)	23
4. Installation	25
4.1 Environmental Requirements	25
4.2 Ambient Temperature / Heat Transmission	25
4.2.1 Emergency shutdown at Overtemperature	28
4.3 Mechanical Tests	31
4.4 Lens mounting	32
4.5 Modular tube systems (ordered separately)	33
4.5.1 Tube Adapter M62	33
4.5.2 Tube Adapter M92	35
4.6 IP Protection classes	37
4.7 Cables	39
4.8 Cleaning	40
5. Pin Assignment / LED-Signaling	41
5.1 VLXT(.I) (.EF) (.JP) (10GBASE-T) / VLXN.I.JP (5GBASE-T)	41
5.1.1 Data Interface	41
5.1.2 Power and Process Interface	41
5.1.3 UART0 Interface (≥ Release 3 only)	42
5.1.4 Digital-IO	43
5.1.5 LED Signaling	44
5.2 VLXT.FO (10GBASE-SR/LR)	45
5.2.1 Data Interface	45
5.2.2 Transceiver / Cables	45
5.2.3 Power and Process Interface	46
5.2.4 UART0 Interface (≥ Release 3 only)	46
5.2.5 Digital-IO	47
5.2.6 LED Signaling	48
6. Product Specifications	49
6.1 Spectral Sensitivity	49
6.2 Sensor position accuracy	53
6.3 Software	54
6.3.1 Baumer GAPI	54
6.3.2 NeoAPI	54
6.3.3 3 rd Party Software	54
7. Camera Functions	55
7.1 Category: AcquisitionControl	56

7.1.1	AcquisitionAbort	56
7.1.2	AcquisitionFrameCount	56
7.1.3	AcquisitionFrameRate	56
7.1.4	AcquisitionFrameRateEnable	57
7.1.5	AcquisitionMode	57
7.1.6	AcquisitionStart	58
7.1.7	AcquisitionStatus	58
7.1.8	AcquisitionStatusSelector	58
7.1.9	AcquisitionStop	59
7.1.10	ExposureAuto (≥ Release 2 only)	59
7.1.11	ExposureMode	59
7.1.12	ExposureTime	60
7.1.13	ExposureTimeGapMax (≥ Release 3 only)	61
7.1.14	ExposureTimeGapMin (≥ Release 3 only)	62
7.1.15	ReadoutMode	62
7.1.16	ShortExposureTimeEnable	63
7.1.17	TriggerActivation	63
7.1.18	TriggerDelay	63
7.1.19	TriggerMode	64
7.1.20	TriggerOverlap	64
7.1.21	TriggerSelector	64
7.1.22	TriggerSoftware	64
7.1.23	TriggerSource	65
7.2	Category: ActionControl	66
7.2.1	ActionDeviceKey	66
7.2.2	ActionGroupKey	66
7.2.3	ActionGroupMask	66
7.2.4	ActionSelector	67
7.3	Category: AnalogControl	67
7.3.1	BalanceWhiteAuto (color cameras only)	67
7.3.2	BlackLevel	68
7.3.3	BlackLevelSelector	69
7.3.4	Gain	69
7.3.5	GainAuto (≥ Release 2 only)	70
7.3.6	GainSelector	70
7.3.7	Gamma	71
7.3.8	HighConversionGainEnable	71
7.3.9	HighConversionGain	71
7.4	Category: AutoFeatureControl (≥ Release 2 only)	72
7.4.1	AutoFeatureHeight	74
7.4.2	AutoFeatureOffsetX	74
7.4.3	AutoFeatureOffsetY	75
7.4.4	AutoFeatureRegionMode	75
7.4.5	AutoFeatureRegionReference	76
7.4.6	AutoFeatureRegionSelector	76
7.4.7	AutoFeatureWidth	76
7.4.8	BalanceWhiteAutoStatus	77
7.4.9	BrightnessAutoNominalValue	77
7.4.10	BrightnessAutoPriority	77
7.4.11	ExposureAutoMaxValue	78
7.4.12	ExposureAutoMinValue	79
7.4.13	GainAutoMaxValue	79
7.4.14	GainAutoMinValue	79
7.5	Category: ChunkDataControl	80
7.5.1	ChunkEnable	81
7.5.2	ChunkModeActive	81
7.5.3	ChunkSelector	81
7.6	Category: ColorTransformationControl (color cameras only)	83
7.6.1	ColorTransformationAuto	83
7.6.2	ColorTransformationEnable	83
7.6.3	ColorTransformationFactoryListSelector	84
7.6.4	ColorTransformationOutputColorSpace (≥ Release 2 only)	84

7.6.5	ColorTransformationResetToFactoryList	84
7.6.6	ColorTransformationValue	85
7.6.7	ColorTransformationValueSelector	85
7.7	Category: CounterAndTimerControl	85
7.7.1	CounterDuration	85
7.7.2	CounterEventActivation	86
7.7.3	CounterEventSource	86
7.7.4	CounterReset	86
7.7.5	CounterResetActivation	87
7.7.6	CounterResetSource	87
7.7.7	CounterSelector	87
7.7.8	CounterValue	88
7.7.9	CounterValueAtReset	88
7.7.10	FrameCounter	88
7.7.11	TimerDelay	89
7.7.12	TimerDuration	89
7.7.13	TimerSelector	89
7.7.14	TimerTriggerActivation	90
7.7.15	TimerTriggerSource	90
7.8	Category: CustomDataControl (≥ Release 2 only)	91
7.8.1	CustomData	91
7.8.2	CustomDataConfigurationMode	91
7.8.3	CustomDataSelector	91
7.9	Category: DeviceControl	92
7.9.1	DeviceCharacterSet	92
7.9.2	DeviceEventChannelCount	92
7.9.3	DeviceFamilyName	92
7.9.4	DeviceFirmwareVersion	93
7.9.5	DeviceLinkCommandTimeout	93
7.9.6	DeviceLinkHeartbeatMode	93
7.9.7	DeviceLinkHeartbeatTimeout	93
7.9.8	DeviceLinkSelector	94
7.9.9	DeviceLinkSpeed	94
7.9.10	DeviceLinkThroughputLimit	94
7.9.11	DeviceManufacturerInfo	95
7.9.12	DeviceModelName	95
7.9.13	DeviceRegistersEndianness	95
7.9.14	DeviceReset	96
7.9.15	DeviceResetToDeliveryState	96
7.9.16	DeviceSFNCVersionMajor	96
7.9.17	DeviceSFNCVersionMinor	97
7.9.18	DeviceSFNCVersionSubMinor	97
7.9.19	DeviceScanType	97
7.9.20	DeviceSensorType	97
7.9.21	DeviceSerialNumber	98
7.9.22	DeviceStreamChannelCount	98
7.9.23	DeviceStreamChannelEndianness	98
7.9.24	DeviceStreamChannelPacketSize	98
7.9.25	DeviceStreamChannelSelector	99
7.9.26	DeviceStreamChannelType	99
7.9.27	DeviceTLType	99
7.9.28	DeviceTLVersionMajor	99
7.9.29	DeviceTLVersionMinor	100
7.9.30	DeviceTLVersionSubMinor	100
7.9.31	DeviceTemperature	100
7.9.32	DeviceTemperatureExceeded	100
7.9.33	DeviceTemperatureSelector	101
7.9.34	DeviceTemperatureStatus	101
7.9.35	DeviceTemperatureStatusTransition	101
7.9.36	DeviceTemperatureStatusTransitionSelector	102
7.9.37	DeviceType	102
7.9.38	DeviceUserID	102
7.9.39	DeviceVendorName	103

7.9.40	DeviceVersion	103
7.9.41	ReadOutTime	103
7.9.42	TimestampLatch	104
7.9.43	TimestampLatchValue	104
7.9.44	TimestampLatchValuePtpDays (≥ Release 2 only)	104
7.9.45	TimestampLatchValuePtpHours (≥ Release 2 only)	104
7.9.46	TimestampLatchValuePtpMinutes (≥ Release 2 only)	105
7.9.47	TimestampLatchValuePtpSeconds (≥ Release 2 only)	105
7.9.48	TimestampLatchValuePtpNanoseconds (≥ Release 2 only)	105
7.9.49	TimestampReset	105
7.10	Category: DigitalIOControl	106
7.10.1	LineDebouncerHighTimeAbs	108
7.10.2	LineDebouncerLowTimeAbs	108
7.10.3	LineFormat	109
7.10.4	LineInverter	110
7.10.5	LineMode	110
7.10.6	LinePWMConfigurationMode	111
7.10.7	LinePWMDuration	112
7.10.8	LinePWMDutyCycle	112
7.10.9	LinePWMMaxDuration	113
7.10.10	LinePWMMaxDutyCycle	113
7.10.11	LinePWMMode	113
7.10.12	LinePWMOffTime	114
7.10.13	LinePWMPeriodTime	114
7.10.14	LineSelector	115
7.10.15	LineSource	116
7.10.16	LineStatus	117
7.10.17	LineStatusAll	117
7.10.18	UserOutputSelector	118
7.10.19	UserOutputValue	118
7.10.20	UserOutputValueAll	118
7.11	Category: EventControl	119
7.11.1	EventNotification	119
7.11.2	EventSelector	119
7.11.3	LostEventCounter	121
7.12	Category: HDRControl	121
7.12.1	HDREnable	125
7.12.2	HDRExposureTimeBrightArea	126
7.12.3	HDRExposureTimeDarkArea	126
7.12.4	HDRGainBrightArea	127
7.12.5	HDRGainDarkArea	127
7.12.6	HDRGainRatio	128
7.12.7	HDRExposureTimeRatio	128
7.12.8	HDRGainRatioSelector	129
7.12.9	HDRProcessingEnable	129
7.12.10	HDRProcessingThresholdMax	130
7.12.11	HDRProcessingThresholdMin	130
7.12.12	HDRSplitviewEnable	131
7.12.13	Category: HDRTonemappingCurveControl	132
7.12.13.1	HDRTonemappingCurveGradient	133
7.12.13.2	HDRTonemappingCurveGridpoint	133
7.12.13.3	HDRTonemappingCurveGridpointIndex	133
7.12.13.4	HDRTonemappingCurveOffset	134
7.12.14	HDRTonemappingCurvePresetSelector	134
7.12.15	HDRTonemappingCurveResetToPreset	135
7.12.16	HDRTonemappingEnable	135
7.13	Category: ImageFormatControl	136
7.13.1	BinningHorizontal	139
7.13.2	BinningHorizontalMode	140
7.13.3	BinningSelector	140
7.13.4	BinningVertical	141
7.13.5	BinningVerticalMode	142

7.13.6 DecimationHorizontal	142
7.13.7 DecimationHorizontalMode	142
7.13.8 DecimationVertical.....	143
7.13.9 DecimationVerticalMode.....	143
7.13.10 Height	143
7.13.11 HeightMax.....	145
7.13.12 ImageCompressionBitRate (VLXN only)	146
7.13.13 ImageCompressionJPEGFormatOption (.JP cameras only)	146
7.13.14 ImageCompressionMode (.JP cameras only)	147
7.13.15 ImageCompressionQuality (.JP cameras only)	148
7.13.16 ImageCompressionRateOption (.JP cameras only)	149
7.13.17 OffsetX.....	150
7.13.18 OffsetY.....	150
7.13.19 PixelFormat	151
7.13.20 RegionMode (≥ Release 3 only).....	153
7.13.21 RegionSelector (≥ Release 3 only).....	154
7.13.22 ReverseX (only mono cameras / pixel formats)	155
7.13.23 ReverseY (only monochrome cameras / pixel formats).....	155
7.13.24 SensorADDigitization	155
7.13.25 SensorHeight.....	156
7.13.26 SensorName (≥ Release 2 only)	156
7.13.27 SensorPixelHeight (≥ Release 2 only).....	156
7.13.28 SensorPixelWidth (≥ Release 2 only).....	156
7.13.29 SensorWidth	157
7.13.30 TestPattern	157
7.13.31 TestPatternGeneratorSelector	158
7.13.32 Width	158
7.13.33 WidthMax.....	160
7.14 Category: ImageProcessingControl (≥ Release 3 only).....	161
7.14.1 ShadingCalibrationStart	162
7.14.2 ShadingEnable	162
7.14.3 SharpeningFactor.....	162
7.14.4 SharpeningMode	163
7.14.5 SharpeningSensitivityThreshold.....	163
7.15 Category: LUTControl	164
7.15.1 DefectPixelCorrection.....	166
7.15.2 DefectPixelListEntryActive	166
7.15.3 DefectPixelListEntryPosX.....	167
7.15.4 DefectPixelListEntryPosY.....	167
7.15.5 DefectPixelListIndex.....	167
7.15.6 DefectPixelListSelector	167
7.15.7 LUTContent	168
7.15.8 LUTEnable	168
7.15.9 LUTIndex.....	168
7.15.10 LUTSelector.....	168
7.15.11 LUTValue	169
7.16 Category: MemoryManagement	169
7.16.1 MemoryFreeBlocks.....	169
7.16.2 MemoryMaxBlocks	170
7.17 Category: OpticControl (≥ Release 3 / .EF only).....	170
7.17.1 Aperture (.EF only)	170
7.17.2 ApertureInitialize (.EF only)	170
7.17.3 ApertureStatus (.EF only)	171
7.17.4 ApertureStepper (.EF only).....	171
7.17.5 FocalLength.....	171
7.17.6 FocalLengthInitialize (.EF only)	172
7.17.7 FocalLengthStatus (.EF only)	172
7.17.8 FocusInitialize (.EF only)	172
7.17.9 FocusStatus (.EF only)	173
7.17.10 FocusStepper	173
7.17.11 OpticControllerDisconnect.....	174
7.17.12 OpticControllerFamilyName (except .EF).....	174

7.17.13	OpticControllerFirmwareVersion	174
7.17.14	OpticControllerInitialize	175
7.17.15	OpticControllerModelName (except .EF)	175
7.17.16	OpticControllerSelector	175
7.17.17	OpticControllerSerialNumber (except .EF).....	175
7.17.18	OpticControllerStatus	176
7.17.19	OpticControllerTemperature (except .EF).....	176
7.17.20	OpticControllerThermalCompensation (except .EF)	176
7.17.21	OpticControllerVendorName	177
7.17.22	OpticControllerVersion (except .EF).....	177
7.18	Category: SequencerControl	178
7.18.1	SequencerConfigurationMode.....	179
7.18.2	SequencerFeatureEnable	179
7.18.3	SequencerFeatureSelector	180
7.18.4	SequencerMode	181
7.18.5	SequencerPathSelector	181
7.18.6	SequencerSetActive	181
7.18.7	SequencerSetLoad.....	182
7.18.8	SequencerSetNext	182
7.18.9	SequencerSetSave	182
7.18.10	SequencerSetSelector	182
7.18.11	SequencerSetStart	183
7.18.12	SequencerTriggerActivation	183
7.18.13	SequencerTriggerSource	184
7.19	Category: TransferControl.....	185
7.19.1	TransferStart.....	185
7.19.2	TransferStatus	185
7.19.3	TransferStatusSelector	185
7.19.4	TransferStop	186
7.20	Category: TransportLayerControl.....	186
7.20.1	EnergyEfficientEthernetEnable (≥ Release 2 only)	186
7.20.2	Category: GigEVision	187
7.20.2.1	GVSPConfigurationBlockID64Bit.....	187
7.20.2.2	GevCCP.....	187
7.20.2.3	GevCurrentDefaultGateway.....	187
7.20.2.4	GevCurrentIPAddress	188
7.20.2.5	GevCurrentIPConfigurationDHCP	188
7.20.2.6	GevCurrentIPConfigurationLLA	188
7.20.2.7	GevCurrentIPConfigurationPersistentIP	188
7.20.2.8	GevCurrentSubnetMask	189
7.20.2.9	GevFirstURL	189
7.20.2.10	GevGVCPExtendedStatusCodes	189
7.20.2.11	GevGVCPExtendedStatusCodesSelector	189
7.20.2.12	GevGVCPPendingAck.....	190
7.20.2.13	GevIPConfigurationStatus	190
7.20.2.14	GevInterfaceSelector	190
7.20.2.15	GevMACAddress	190
7.20.2.16	GevMCDA.....	191
7.20.2.17	GevMCPHostPort	191
7.20.2.18	GevMCRC.....	191
7.20.2.19	GevMCSP	191
7.20.2.20	GevMCTT	192
7.20.2.21	GevNumberOfInterfaces	192
7.20.2.22	GevPAUSEFrameReception.....	192
7.20.2.23	GevPersistentDefaultGateway.....	192
7.20.2.24	GevPersistentIPAddress	193
7.20.2.25	GevPersistentSubnetMask	193
7.20.2.26	GevPrimaryApplicationIPAddress	193
7.20.2.27	GevPrimaryApplicationSocket	193
7.20.2.28	GevPrimaryApplicationSwitchoverKey.....	194
7.20.2.29	GevSCDA.....	194
7.20.2.30	GevSCFTD	194
7.20.2.31	GevSCPD	194

7.20.2.32	GevSCPHostPort	195
7.20.2.33	GevSCPIInterfaceIndex	195
7.20.2.34	GevSCPSDoNotFragment	195
7.20.2.35	GevSCPSFireTestPacket	195
7.20.2.36	GevSCPSPacketSize	196
7.20.2.37	GevSCSP	196
7.20.2.38	GevSecondURL	196
7.20.2.39	GevStreamChannelSelector	196
7.20.2.40	GevSupportedOption	197
7.20.2.41	GevSupportedOptionSelector	197
7.20.2.42	InterfaceSpeedMode	198
7.20.3	PayloadSize	198
7.20.4	Category: TransportLayerControl → PtpControl (≥ Release 2 only)	199
7.20.4.1	PtpClockAccuracy	201
7.20.4.2	PtpClockID	201
7.20.4.3	PtpDataSetLatch	201
7.20.4.4	PtpEnable	202
7.20.4.5	PtpGrandmasterClockID	202
7.20.4.6	PtpMode	202
7.20.4.7	PtpOffsetFromMaster	203
7.20.4.8	PtpParentClockID	203
7.20.4.9	PtpServoStatus	203
7.20.4.10	PtpServoStatusThreshold	204
7.20.4.11	PtpStatus	204
7.20.4.12	PtpSyncMessageInterval (≥ Release 3 only)	204
7.20.4.13	PtpSyncMessageIntervalStatus (≥ Release 3 only)	205
7.21	Category: UserSetControl	205
7.21.1	UserSetDefault	205
7.21.2	UserSetFeatureEnable	206
7.21.3	UserSetFeatureSelector	206
7.21.4	UserSetLoad	207
7.21.5	UserSetSave	208
7.21.6	UserSetSelector	208
7.22	Category: boSerialControl	209
7.22.1	boSerialASCIIReadBuffer	209
7.22.2	boSerialASCIIWriteBuffer	209
7.22.3	boSerialBinaryReadBuffer	209
7.22.4	boSerialBinaryWriteBuffer	210
7.22.5	boSerialBytesAvailableForRead	210
7.22.6	boSerialBytesRead	210
7.22.7	boSerialBytesToRead	210
7.22.8	boSerialBytesToWrite	211
7.22.9	boSerialBytesWritten	211
7.22.10	boSerialConfigBaudRate	211
7.22.11	boSerialConfigDataBits	212
7.22.12	boSerialConfigParity	212
7.22.13	boSerialConfigStopBits	212
7.22.14	boSerialMode	213
7.22.15	boSerialRead	213
7.22.16	boSerialSelector	213
7.22.17	boSerialStatus	214
7.22.18	boSerialWrite	214
8.	Interface Functionalities	215
8.1	Device Information	215
8.2	Packet Size and Maximum Transmission Unit (MTU)	215
8.3	Inter Packet Gap (IPG)	216
8.3.1	Example 1: Multi Camera Operation – Minimal IPG	216
8.3.2	Example 2: Multi Camera Operation – Optimal IPG	217
8.4	Frame Delay	218

8.4.1 Time Saving in Multi-Camera Operation	218
8.4.2 Configuration Example (GigE).....	219
8.5 Multicast.....	221
8.6 IP Configuration	222
8.6.1 Persistent IP	222
8.6.2 DHCP (Dynamic Host Configuration Protocol).....	222
8.6.3 LLA	223
8.6.4 Force IP.....	223
8.7 Packet Resend.....	224
8.7.1 Normal Case.....	224
8.7.2 Fault 1: Lost Packet within Data Stream	224
8.7.3 Fault 2: Lost Packet at the End of the Data Stream	225
8.7.4 Termination Conditions	225

1. General Information

Thanks for purchasing a camera of the Baumer family. This User's Guide describes how to connect, set up and use the camera.



Read this manual carefully and observe the notes and safety instructions!

Support

In case of any questions please contact our Technical & Application Support Center.

Worldwide: **Baumer Optronic GmbH**
Badstrasse 30
DE-01454 Radeberg, Germany

Tel: +49 (0)3528 4386 845

Website: www.baumer.com

E-mail: support.cameras@baumer.com

Target group for this User's Guide

This User's Guide is aimed at experienced users, which want to integrate camera(s) into a vision system.

Intended Use

The camera is used to capture images that can be transferred to a PC.

It has a compact housing suitable for industrial use and are designed exclusively for indoor use. The use in wet locations is permissible under consideration of the IP protection class.

Notice

Use the camera only for its intended purpose!

For any use that is not described in the technical documentation poses dangers and will void the warranty. The risk has to be borne solely by the unit's owner.

Classification of the safety instructions

In the User's Guide, the safety instructions are classified as follows:

Notice

Gives helpful notes on operation or other general recommendations.



Caution



Indicates a possibly dangerous situation. If the situation is not avoided, slight or minor injury could result or the device may be damaged.



Danger!



Indicates an immediate imminent danger. If the danger is not avoided, the consequences are death or very serious injury.

Disposal



Dispose of outdated products with electrical or electronic circuits, not in the normal domestic waste, but rather according to your national law and the directives 2002/96/EC and 2006/66/EG for recycling within the competent collectors.

Through the proper disposal of obsolete equipment will help to save valuable resources and prevent possible adverse effects on human health and the environment.

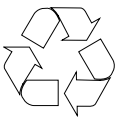

The return of the packaging to the material cycle helps conserve raw materials and reduces the production of waste. When no longer required, dispose of the packaging materials in accordance with the local regulations in force.

Keep the original packaging during the warranty period in order to be able to pack the device properly in the event of a warranty claim.

Warranty Notes

If it is obvious that the device is / was dismantled, reworked or repaired by other than Baumer technicians, Baumer Optronic will not take any responsibility for the subsequent performance and quality of the device!

Copyright

Any duplication or reprinting of this documentation, in whole or in part, and the reproduction of the illustrations even in modified form is permitted only with the written approval of Baumer. The information in this document is subject to change without notice.

1.1 Software Licensing Information

The software in the camera includes the LWIP TCP/IP implementation. The copyright information for this implementation is as follows:

Copyright (c) 2001, 2002 Swedish Institute of Computer Science. All rights reserved.

Redistribution and use in source and binary forms, with or without modification, are permitted provided that the following conditions are met:

1. Redistributions of source code must retain the above copyright notice, this list of conditions and the following disclaimer.
2. Redistributions in binary form must reproduce the above copyright notice, this list of conditions and the following disclaimer in the documentation and/or other materials provided with the distribution.
3. The name of the author may not be used to endorse or promote products derived from this software without specific prior written permission.

THIS SOFTWARE IS PROVIDED BY THE AUTHOR ``AS IS" AND ANY EXPRESS OR IMPLIED WARRANTIES, INCLUDING, BUT NOT LIMITED TO, THE IMPLIED WARRANTIES OF MERCHANTABILITY AND FITNESS FOR A PARTICULAR PURPOSE ARE DISCLAIMED.

IN NO EVENT SHALL THE AUTHOR BE LIABLE FOR ANY DIRECT, INDIRECT, INCIDENTAL, SPECIAL, EXEMPLARY, OR CONSEQUENTIAL DAMAGES (INCLUDING, BUT NOT LIMITED TO, PROCUREMENT OF SUBSTITUTE GOODS OR SERVICES; LOSS OF USE, DATA, OR PROFITS; OR BUSINESS INTERRUPTION) HOWEVER CAUSED AND ON ANY THEORY OF LIABILITY, WHETHER IN CONTRACT, STRICT LIABILITY, OR TORT (INCLUDING NEGLIGENCE OR OTHERWISE) ARISING IN ANY WAY OUT OF THE USE OF THIS SOFTWARE, EVEN IF ADVISED OF THE POSSIBILITY OF SUCH DAMAGE.

The software in the camera includes the ptpd implementation. The copyright information for this implementation is as follows:

Copyright (c) 2015 Wojciech Owczarek.

Copyright (c) 2014 Perseus Telecom.

Copyright (c) 2013-2014 Harlan Stenn,
George N. Neville-Neil,
Wojciech Owczarek,
Jan Breuer.

Copyright (c) 2011-2012 George V. Neville-Neil,
Steven Kreuzer,
Martin Burnicki,
Jan Breuer,
Wojciech Owczarek,
Gael Mace,
Alexandre Van Kempen,
Inaqui Delgado,
Rick Ratzel,
National Instruments.

Copyright (c) 2009-2010

George V. Neville-Neil,
Steven Kreuzer,
Martin Burnicki,
Jan Breuer,
Gael Mace,
Alexandre Van Kempen.

Copyright (c) 2005-2008

Kendall Correll, Aidan Williams

All Rights Reserved

Redistribution and use in source and binary forms, with or without modification, are permitted provided that the following conditions are met:

1. Redistributions of source code must retain the above copyright notice this list of conditions and the following disclaimer.
2. Redistributions in binary form must reproduce the above copyright notice, this list of conditions and the following disclaimer in the documentation and/or other materials provided with the distribution.

THIS SOFTWARE IS PROVIDED BY THE AUTHORS ``AS IS" AND ANY EXPRESS OR IMPLIED WARRANTIES, INCLUDING, BUT NOT LIMITED TO, THE IMPLIED WARRANTIES OF MERCHANTABILITY AND FITNESS FOR A PARTICULAR PURPOSE ARE DISCLAIMED. IN NO EVENT SHALL THE AUTHORS OR CONTRIBUTORS BE LIABLE FOR ANY DIRECT, INDIRECT, INCIDENTAL, SPECIAL, EXEMPLARY, OR CONSEQUENTIAL DAMAGES (INCLUDING, BUT NOT LIMITED TO, PROCUREMENT OF SUBSTITUTE GOODS OR SERVICES; LOSS OF USE, DATA, OR PROFITS; OR BUSINESS INTERRUPTION) HOWEVER CAUSED AND ON ANY THEORY OF LIABILITY, WHETHER IN CONTRACT, STRICT LIABILITY, OR TORT (INCLUDING NEGLIGENCE OR OTHERWISE) ARISING IN ANY WAY OUT OF THE USE OF THIS SOFTWARE, EVEN IF ADVISED OF THE POSSIBILITY OF SUCH DAMAGE.

2. General safety Instructions

Caution

Heat can damage the camera. Provide adequate dissipation of heat, to ensure that the temperature does not exceed the value (see Heat Transmission).



As there are numerous possibilities for installation, Baumer recommends no specific method for proper heat dissipation, but suggest the following principle:

- operate the cameras only in mounted condition with free air circulation
- mounting in combination with forced convection may provide proper heat dissipation

[see chapter „4.2 Ambient Temperature / Heat Transmission“ on page 25](#)

Caution



Observe precautions for handling electrostatic sensitive devices!

Caution

Danger from lighting used.



Exposure to light, especially ultraviolet (UV) light, can be harmful and cause damage to the eyes/skin.

Observe the safety instructions in the technical documentation for the lighting used!

3. Camera Models

All Baumer cameras of these family are characterized by:

- High image quality
 - Global shutter architecture for minimized motion blur
 - Image data buffer for reliable image transmission
- Fast image transfer
 - 10 Gigabit Ethernet (VLXT)
 - 5 Gigabit Ethernet (VLXN)
- Perfect integration
 - Flexible generic programming interface (Baumer GAPI) for all Baumer cameras
 - Powerful Software Development Kit (SDK) with sample codes and help files for simple integration
 - Baumer Camera Explorer (Baumer GAPI Test Tool) for testing all camera functions
 - GenICam™ compliant XML file to describe the camera functions
 - Camera parameter programmable in real-time
- Reliable operation
 - State-of-the-art camera electronics and precision mechanics
 - Image data buffer for reliable image transmission
 - Very robust M12 connectors
- Supported standards
 - GigE Vision® 2.0.0
 - GenICam SFNC 2.3.0 / SFNC 2.4.0 (≥ Rel. 2 only)
 - IEEE 1588™-2008 (≥ Rel. 2 only)

Conformity CE We declare, under our sole responsibility, that the previously described Baumer cameras conform with the directives of the CE.



UL The camera has been tested by UL (Underwriters Laboratories) and complies with the requirements of the standards:

- UL 61010-1 Edition 3 - Revision Date: 2016/04/29
- UL 61010-2-201 Edition 2 - Published: 2018/05/14
- CSA C22.2 NO. 61010-1-12 Edition 3 - Update No. 2: 2016/04
- CSA C22.2 NO. 61010-2-201:18 Edition 2 - Published: 2018/02



UR The camera has been tested by UL (Underwriters Laboratories) and complies with the requirements under **specified installation conditions** of the standards:

- UL 61010-1 Edition 3 - Revision Date: 2016/04/29
- UL 61010-2-201 Edition 2 - Published: 2018/05/14
- CSA C22.2 NO. 61010-1-12 Edition 3 - Update No. 2: 2016/04
- CSA C22.2 NO. 61010-2-201:18 Edition 2 - Published: 2018/02



KC Several of the described Baumer cameras conform with the directives of the Korean Conformity.



(see table on next page)

Korean Conformity (Registration of Broadcasting and Communication Equipments)

Product	Article No.	Registration No.	Date of Registration
Monochrome			
VLXT-06M.I	11701258	R-R-BkR-VLXT-71MI	2021-03-18
VLXT-06M.I.JP	11700830	R-R-BkR-VLXT-71MI	2021-03-18
VLXT-17M.I	11701259	R-R-BkR-VLXT-71MI	2021-03-18
VLXT-28M.I	11700832	R-R-BkR-VLXT-71MI	2021-03-18
VLXT-28M.I.JP	11701720	R-R-BkR-VLXT-71MI	2021-03-18
VLXT-50M.I	11192927	R-R-BkR-VLXT-90MI	2020-10-23
VLXT-71M.I	11700327	R-R-BkR-VLXT-71MI	2021-03-18
VLXT-90M.I	11192926	R-R-BkR-VLXT-90MI	2020-10-23
VLXT-123M.I	11192208	R-R-BkR-VLXT-90MI	2020-10-23
VLXT-650M.I	11700653	R-R-BkR-VLXT-650MI	2022-11-25
VLXT-650M.I.EF	11701462	R-R-BkR-VLXT-650MI	2022-11-25
Color			
VLXT-06C.I.JP	11701719	R-R-BkR-VLXT-71MI	2021-03-18
VLXT-31C.I	11194257	R-R-BkR-VLXT-90MI	2020-10-23
VLXT-50C.I	11194256	R-R-BkR-VLXT-90MI	2020-10-23
VLXT-71C.I	11700337	R-R-BkR-VLXT-71MI	2021-03-18
VLXT-90C.I	11194280	R-R-BkR-VLXT-90MI	2020-10-23
VLXT-123C.I	11194269	R-R-BkR-VLXT-90MI	2020-10-23
VLXT-650C.I	11700655	R-R-BkR-VLXT-650MI	2022-11-25
VLXT-650C.I.EF	11701461	R-R-BkR-VLXT-650MI	2022-11-25

Notice

To meet the requirements of the standard for VLXT-490/650 cameras use a power cable with less than 3 m length.

Release Version

Notice

Identification of Release version

- Label on camera
- Baumer GAPI Camera Explorer / Category: *Device Control* → Feature: *Device Version*

Release Version .JP Cameras ↔ Release Version Standard Cameras

The release versions for .JP cameras are counted separately. However, the range of functions partly corresponds to the standard cameras, except for the special JP features. A comparison of the release versions is shown in the following table.

Release Version .JP Cameras	Release Version Standard
Release 1.0.0	Release 2.0.2
Release 1.1.0	Release 3.1.1

3.1 VLXT (.I) (.EF) (.JP) (10GBASE-T)

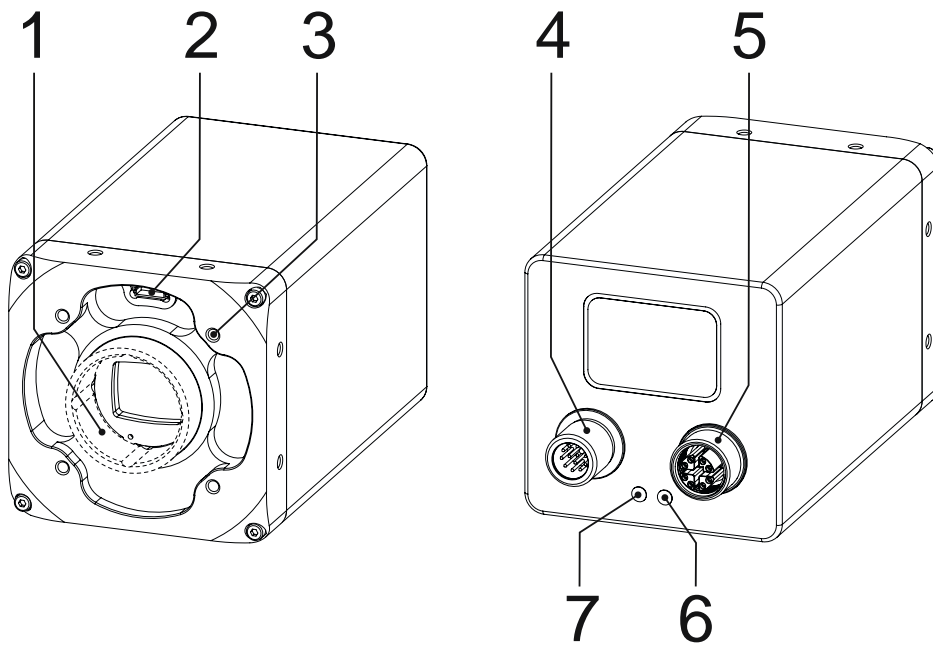

No.	Description	No.	Description
1	Lens mount (C- / M58- / TFL- / EF-Mount)	5	Ethernet Port
2	UART0 Interface (≥ Release 3, C- / EF-Mount only)	6	Camera LED
3	4 x Tube Adapter / front mounting threads (except M58-mount, EF-mount)	7	GigE LED
4	Power- and process interface (including UART1 / RS232)		

Camera Type	Sensor Size	Resolution	Full Frames ¹⁾ [max. fps]
Monochrome			
VLXT-06M.I (.JP)	1/1.7"	800 × 620	1578 1578
VLXT-17M.I	1.1"	1600 × 1100	660 660
VLXT-28M.I (.JP)	2/3"	1920 × 1464	415 411
VLXT-31M.I	1/1.8"	2048 × 1536	217 217
VLXT-50M.I	2/3"	2448 × 2048	164 164
VLXT-55M.I	1/1.8"	2464 × 2048	259 243
VLXT-71M.I	1.1"	3200 × 2200	174 174
VLXT-81M.I	2/3"	2848 × 2832	172 150
VLXT-83UV.I	2/3"	2848 × 2832	172 150
VLXT-90M.I (.JP)	1"	4096 × 2160	95 95
VLXT-123M.I	1.1"	4096 × 3000	69 69
VLXT-126M.I	1/1.1"	4096 × 2992	119 100
VLXT-240M.I	1.2"	5312 × 4600	62 50
VLXT-490M.I (.EF)	2.3"	7008 × 7000	23 23
VLXT-650M.I (.EF)	2.3"	9344 × 7000	23 18

¹⁾ image acquisition in the camera's internal memory | interface (10 GigE)

Camera Type	Sensor Size	Resolution	Full Frames ¹⁾ [max. fps]
Color			
VLXT-06C.I.JP	1/1.7"	800 × 608	1622 1622
VLXT-31C.I (.JP)	1/1.8"	2048 × 1536	215 215
VLXT-50C.I	2/3"	2448 × 2048	163 163
VLXT-55C.I	1/1.8"	2464 × 2048	259 243
VLXT-71C.I	1.1"	3200 × 2200	174 174
VLXT-81C.I	2/3"	2848 × 2832	172 150
VLXT-90C.I	1"	4096 × 2160	95 95
VLXT-123C.I	1.1"	4096 × 3000	69 69
VLXT-126C.I	1/1.1"	4096 × 2992	119 100
VLXT-240C.I	1.2"	5312 × 4600	62 50
VLXT-490C.I (.EF)	2.3"	7008 × 7000	23 23
VLXT-650C.I (.EF)	2.3"	9344 × 7000	23 18

¹⁾ image acquisition in the camera's internal memory | interface (10 GigE)

Dimensions (C-mount)

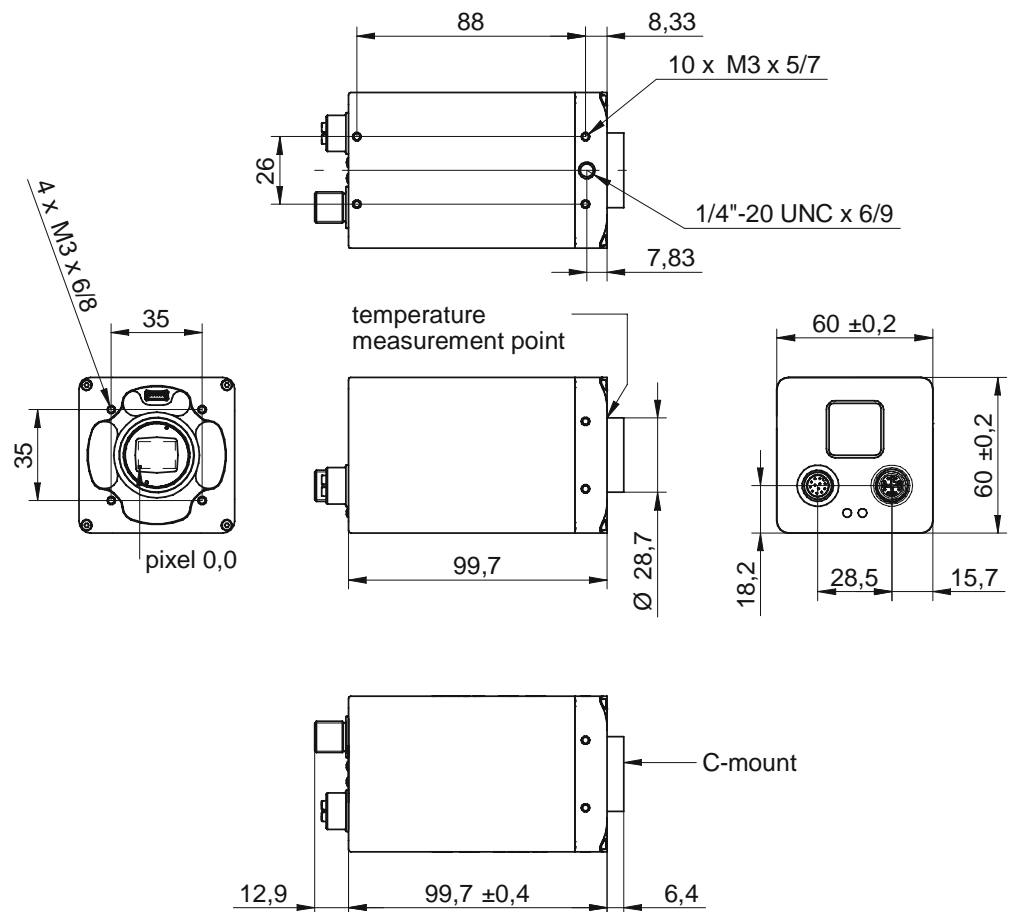

Dimensions (M58-mount)

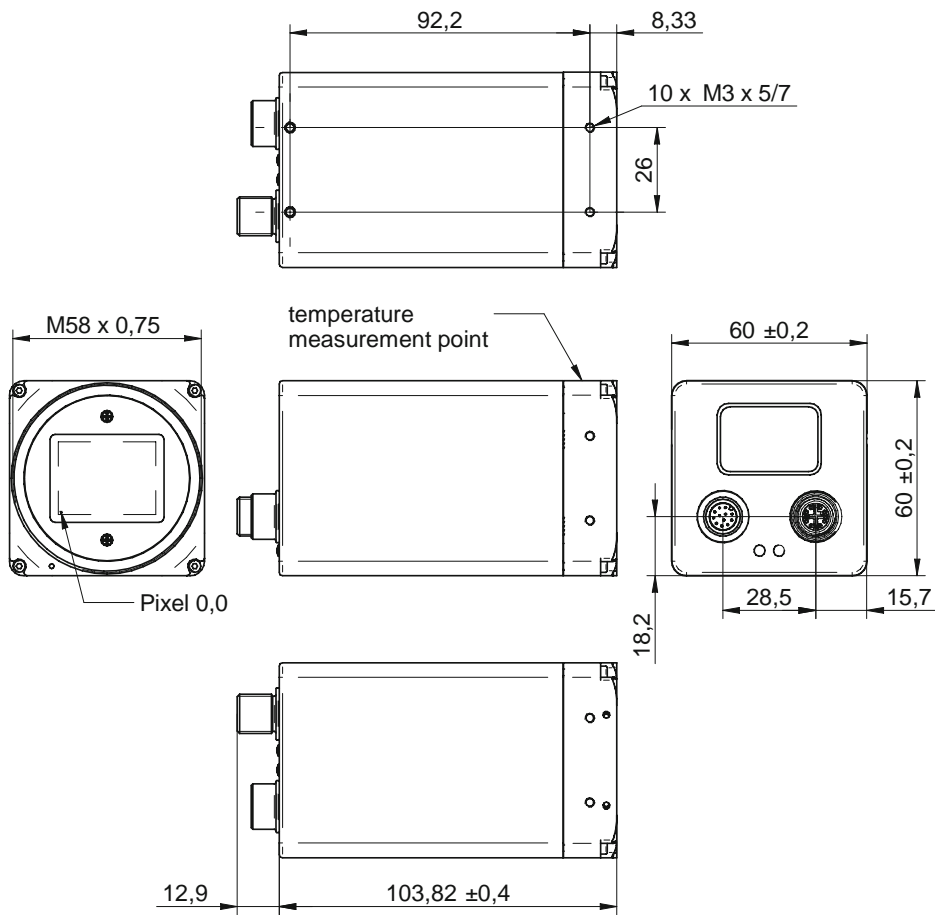

Dimensions (TFL-mount)

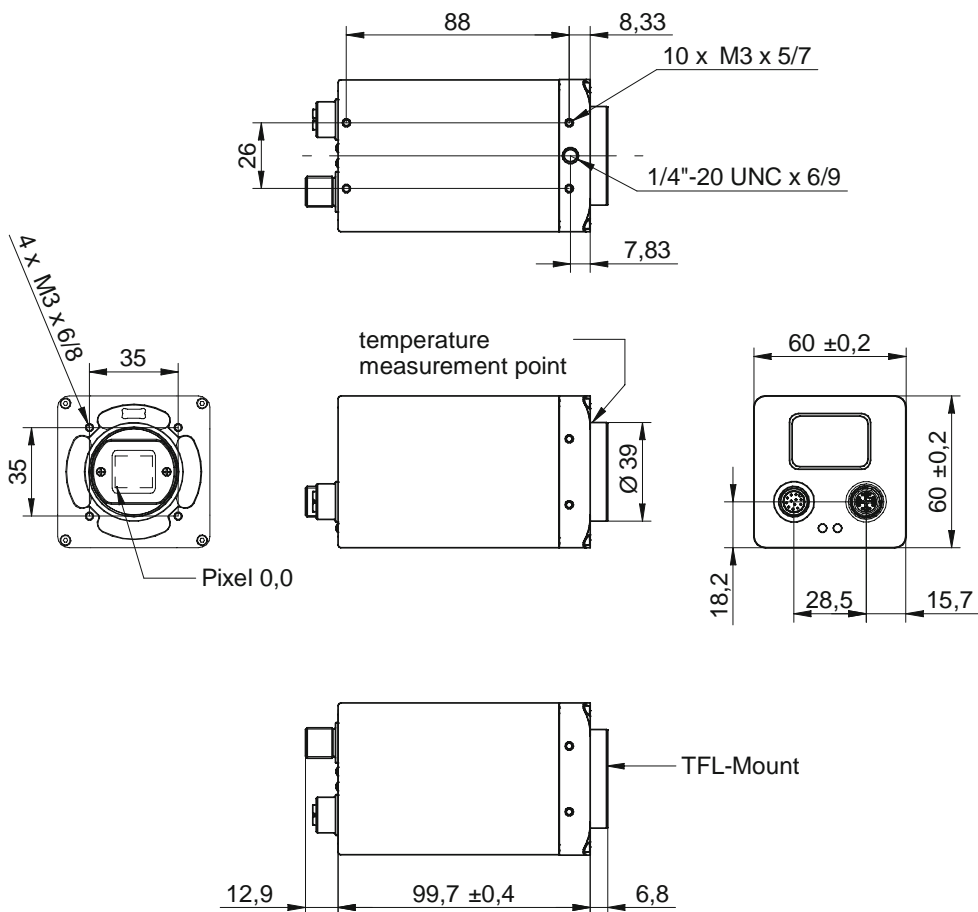

Dimensions (EF-mount)

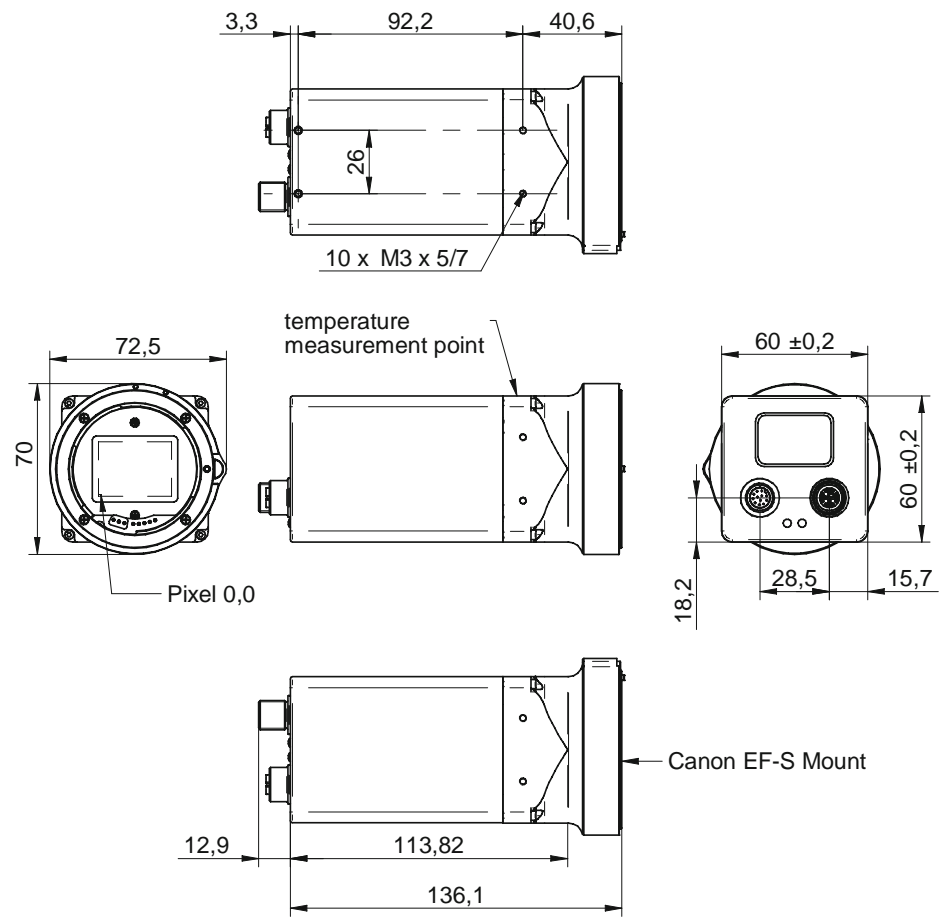

3.2 VLXN.I.JP (5GBASE-T)

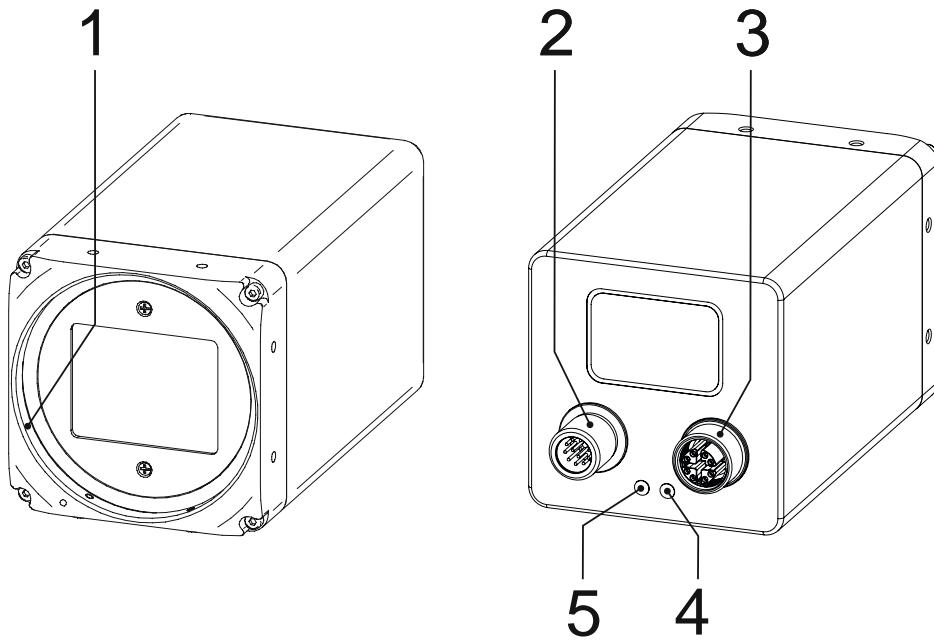

No.	Description	No.	Description
1	Lens mount (M58-Mount)	4	Camera LED
2	Power- and process interface	5	GigE LED
3	Ethernet Port		

Camera Type	Sensor Size	Resolution	Full Frames ¹⁾ [max. fps]
Monochrome			
VLXN-490M.I.JP	2"	7008x 7000	11 11
VLXN-650M.I.JP	2.3"	9344 x 7000	11 9

¹⁾ image acquisition in the camera's internal memory | interface (5 GigE)

Dimensions (M58-mount)

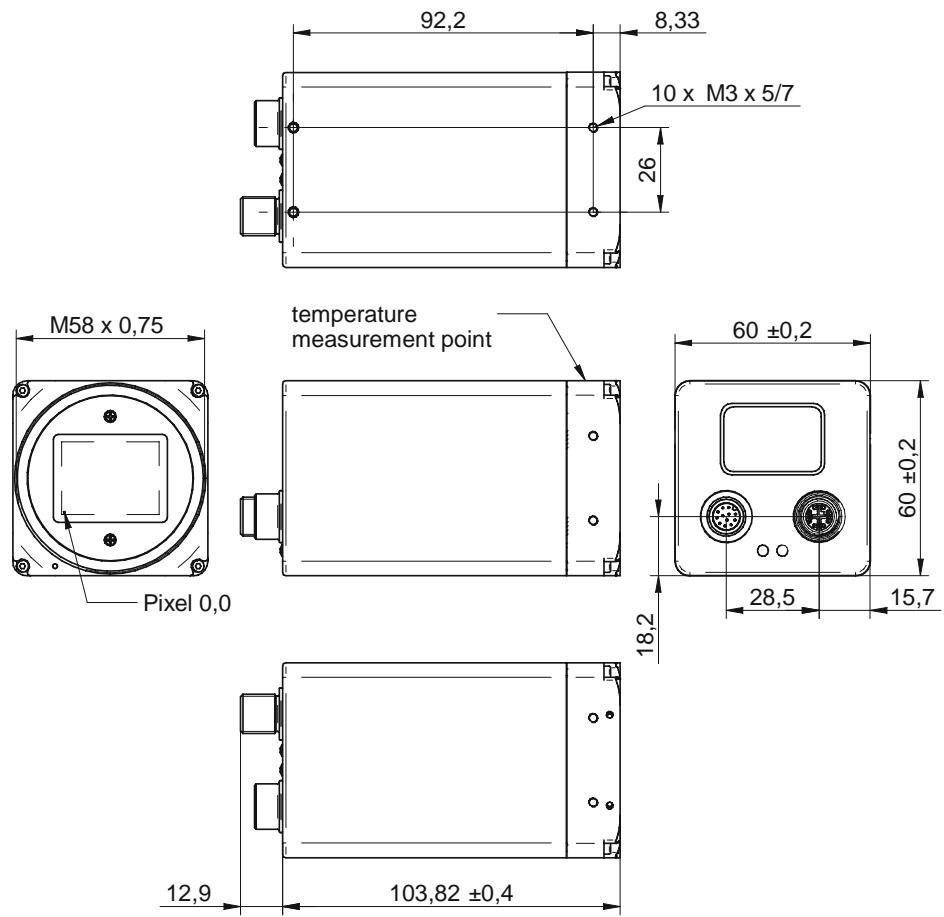

3.3 VLXT.FO (10GBASE-SR/LR)

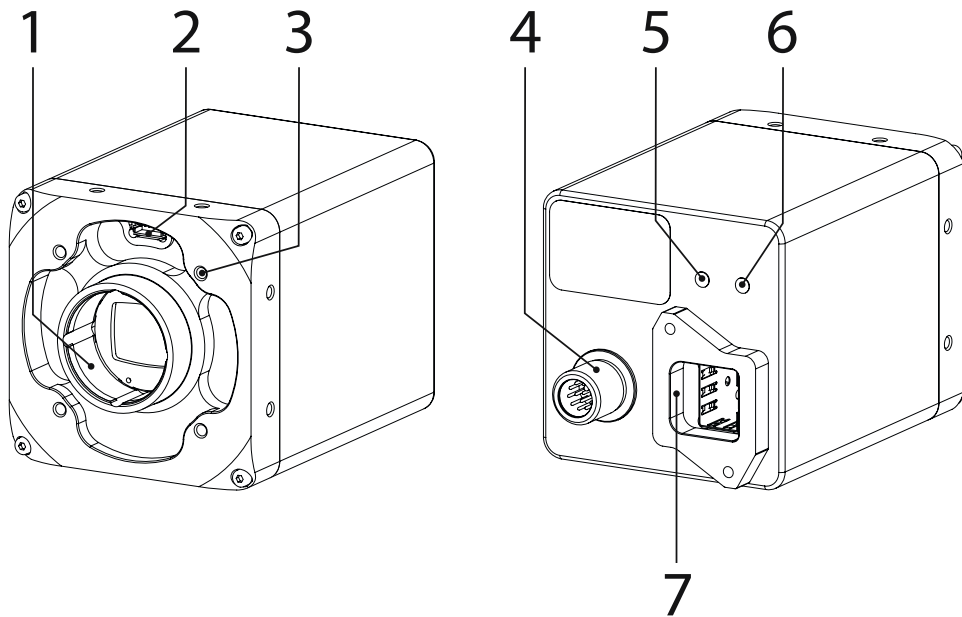

No.	Description	No.	Description
1	Lens mount (C-mount)	5	GigE LED
2	UART0 Interface (≥ Release 3, C- / EF-Mount only)	6	Camera LED
3	4 x Tube Adapter / front mounting threads	7	SFP+ Socket
4	Power- and process interface (including UART1 / RS232)		

Camera Type	Sensor Size	Resolution	Full Frames ¹⁾ [max. fps]
Monochrome			
VLXT-31M.FO	1/1.8"	2048 × 1536	217 217
VLXT-50M.FO	2/3"	2448 × 2048	163 163
VLXT-90M.FO	1"	4096 × 2160	95 95
VLXT-123M.FO	1.1"	4096 × 3000	69 69
Color			
VLXT-50C.FO	2/3"	2448 × 2048	163 163

¹⁾ image acquisition in the camera's internal memory | interface (10 GigE)

Dimensions

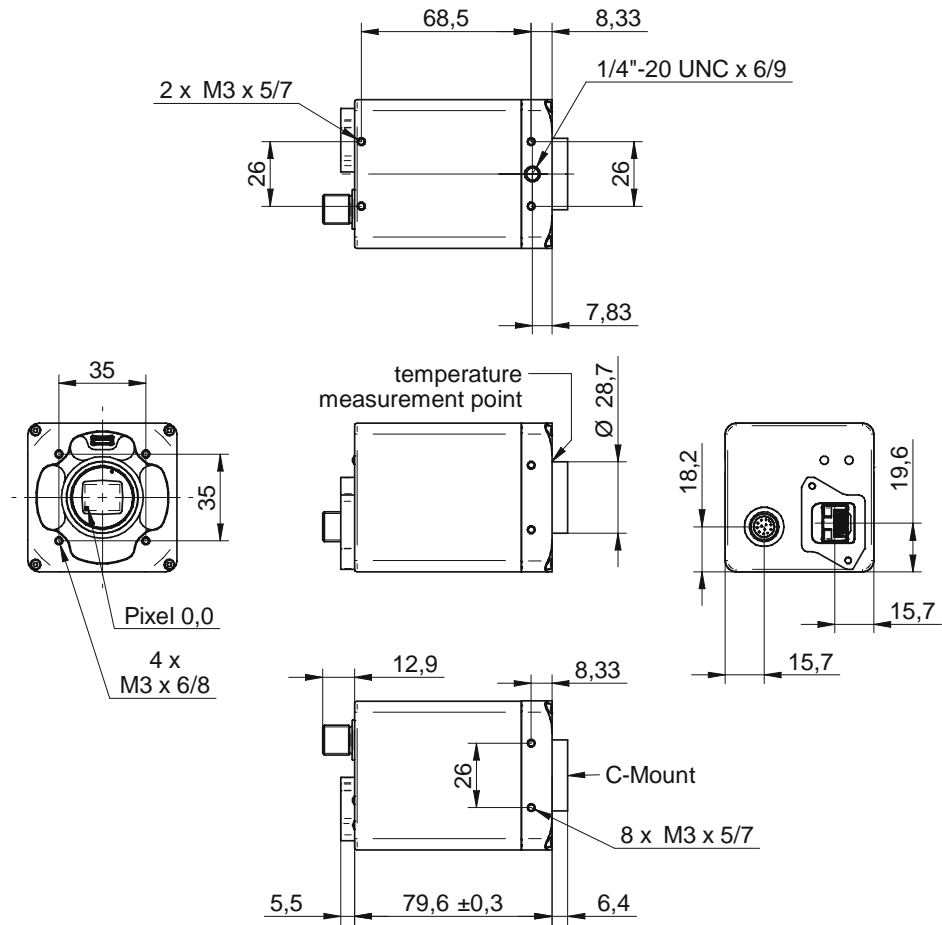

4. Installation



Caution



The installer of the system is responsible for the safety of the system in which the camera is integrated.

4.1 Environmental Requirements

Storage temperature	-10 °C (+14 °F) ... +70 °C (+158 °F)
---------------------	--------------------------------------

Humidity	10 % ... 90 % non condensing
----------	------------------------------

4.2 Ambient Temperature / Heat Transmission



Caution

Heat can damage the camera. Ambient temperature above 25 °C (77 °F) requires heat dissipation measures. Provide adequate dissipation of heat, to ensure that the temperatures does not exceed the specified values.

Baumer recommends the following methods for proper heat dissipation:

- Every form of convection around the device and mounting helps reduce temperature. Prevent heat from becoming trapped!
- Mounting in combination with forced convection may provide proper heat dissipation.
- Avoid mounting onto stainless steel. Stainless steel has a roughly 10-fold lower thermal conductivity compared to aluminium.
- Do not install the device at the end of a profile; this will allow heat to dissipate on both sides (higher temperature drops over a larger area)!
- Do not operate other devices in close proximity to the camera. Their waste heat could additionally heat the camera.
- From an ambient temperature of +30 °C (86 °F) up to +40 °C (104 °F) the camera requires forced air cooling (min. 0.9 m/s).



Max. Temperature Measure Point

Refer to the following tables for the maximum permissible temperature at the temperature measurement point.

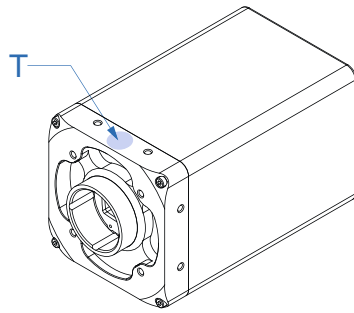

VLXT(N).I (.JP)

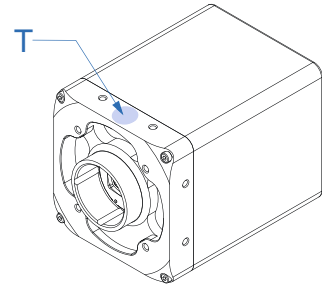

VLXT.FO

VLXT(.I) (.EF) (.JP)

Camera Type	max. Temperature (T = Measurement Point)
Monochrome	
VLXT-06M.I / (.JP)	60 °C (140 °F) / 62 °C (143.6 °F)
VLXT-17M.I	60 °C (140 °F)
VLXT-28M.I (.JP)	60 °C (140 °F) / 62 °C (143.6 °F)
VLXT-31M.I	65 °C (149 °F)
VLXT-50M.I	65 °C (149 °F)
VLXT-55M.I	60 °C (140 °F)
VLXT-71M.I	60 °C (140 °F)
VLXT-81M.I	60 °C (140 °F)
VLXT-83UV.I	60 °C (140 °F)
VLXT-90M.I / (.JP)	65 °C (149 °F) / 65 °C (149 °F)
VLXT-123M.I	65 °C (149 °F)
VLXT-126M.I	60 °C (140 °F)
VLXT-240M.I	60 °C (140 °F)
VLXT-490M.I (.EF)	70 °C (158 °F)
VLXT-650M.I (.EF)	70 °C (158 °F)
Color	
VLXT-06C.I.JP	60 °C (140 °F)
VLXT-31C.I (.JP)	65 °C (149 °F) / 65 °C (149 °F)
VLXT-50C.I	65 °C (149 °F)
VLXT-55C.I	60 °C (140 °F)
VLXT-71C.I	60 °C (140 °F)
VLXT-81C.I	60 °C (140 °F)
VLXT-90C.I	65 °C (149 °F)
VLXT-123C.I	65 °C (149 °F)
VLXT-126C.I	60 °C (140 °F)
VLXT-240C.I	60 °C (140 °F)
VLXT-490C.I (.EF)	70 °C (158 °F)
VLXT-650C.I (.EF)	70 °C (158 °F)

VLXT.FO

Camera Type	max. Temperature (T = Measurement Point)
Monochrome	
VLXT-31M.FO	65 °C (149 °F)
VLXT-50M.FO	65 °C (149 °F)
VLXT-90M.FO	65 °C (149 °F)
VLXT-123M.FO	65 °C (149 °F)
Color	
VLXT-50C.FO	65 °C (149 °F)

VLXN

Camera Type	max. Temperature (T = Measurement Point)
Monochrome	
VLXN-490M.I.JP	70 °C (158 °F)
VLXN-650M.I.JP	70 °C (158 °F)

4.2.1 Emergency shutdown at Overtemperature

To prevent damage on the hardware due to high temperatures, the camera is equipped with an emergency shutdown. The *DeviceTemperatureStatusTransitionSelector* (Category: *Device Control*) feature allows you to select different thresholds for temperatures:

NormalToHigh: freely programmable value

HighToExceeded: fixed value (image recording is stopped if exceeded)

ExceededToNormal: freely programmable value, temperature for error-free re-activation of the camera.

In the *DeviceTemperatureStatusTransition* feature, the temperatures for the programmable temperature transitions are set.

The *Event DeviceTemperatureStatusChanged* is always generated when *DeviceTemperatureStatus* changes.

If the temperature rises above the value set at *HighToExceed*, the *DeviceTemperatureExceeded* feature is set to *True*, the image recording is stopped, and the LED is set to orange.

For further use, the camera must be disconnected from the power supply after cooling down or a device reset should be carried out.

The sufficient cooling is recognizable when the event *EvenDeviceTemperatureStatusChanged* (*Device Temperature < ExceededToNormal*) is output.

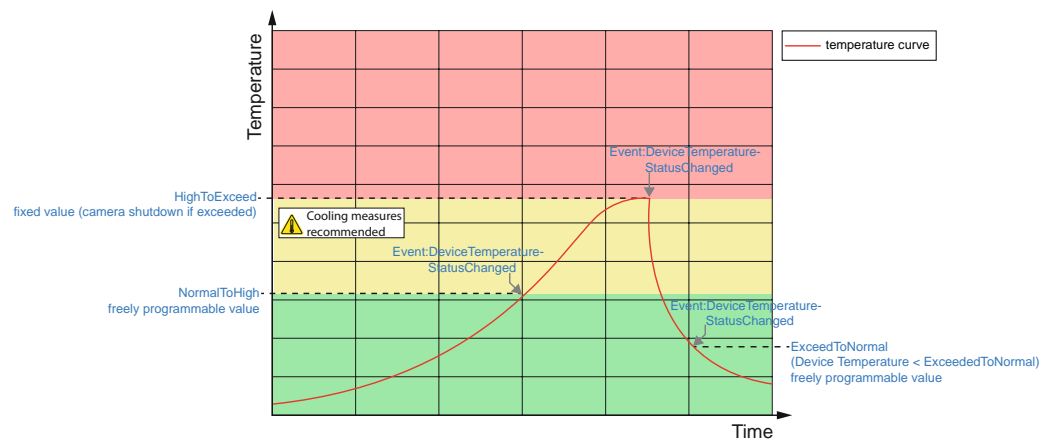

Temperatures for emergency shutdown

When the temperature measurement at the internal temperature sensor gives a temperature exceeding the specified values in the following tables, the *DeviceTemperatureExceeded* feature is set to *True*, the image recording is stopped, and the Camera LED is set to orange.

VLXT(.I) (.EF) (.JP)

Camera Type	Temperatures for emergency shutdown (at internal temperature sensor)
Monochrome	
VLXT-06M.I / (.JP)	69 °C (156.2 °F)
VLXT-17M.I	69 °C (156.2 °F)
VLXT-28M.I (.JP)	69 °C (156.2 °F)
VLXT-31M.I	71 °C (159.8 °F)
VLXT-50M.I	71 °C (159.8 °F)
VLXT-55M.I	69 °C (156.2 °F)
VLXT-71M.I	69 °C (156.2 °F)
VLXT-81M.I	69 °C (156.2 °F)
VLXT-83UV.I	69 °C (156.2 °F)
VLXT-90M.I / (.JP)	71 °C (159.8 °F)
VLXT-123M.I	71 °C (159.8 °F)
VLXT-126M.I	69 °C (156.2 °F)
VLXT-240M.I	69 °C (156.2 °F)
VLXT-490M.I (.EF)	70 °C (158 °F)
VLXT-650M.I (.EF)	70 °C (158 °F)
Color	
VLXT-06C.I.JP	69 °C (156.2 °F)
VLXT-31C.I (.JP)	71 °C (159.8 °F)
VLXT-50C.I	71 °C (159.8 °F)
VLXT-55C.I	69 °C (156.2 °F)
VLXT-71C.I	69 °C (156.2 °F)
VLXT-81C.I	69 °C (156.2 °F)
VLXT-90C.I	71 °C (159.8 °F)
VLXT-123C.I	71 °C (159.8 °F)
VLXT-126C.I	69 °C (156.2 °F)
VLXT-240C.I	69 °C (156.2 °F)
VLXT-490C.I (.EF)	70 °C (158 °F)
VLXT-650C.I (.EF)	70 °C (158 °F)

VLXT.FO

Camera Type	Temperatures for emergency shutdown (at internal temperature sensor)
Monochrome	
VLXT-31M.FO	71 °C (159.8 °F)
VLXT-50M.FO	71 °C (159.8 °F)
VLXT-90M.FO	71 °C (159.8 °F)
VLXT-123M.FO	71 °C (159.8 °F)
Color	
VLXT-50C.FO	71 °C (159.8 °F)

VLXN

Camera Type	Temperatures for emergency shutdown (at internal temperature sensor)
Monochrome	
VLXN-490M.I.JP	70 °C (158 °F)
VLXN-650M.I.JP	70 °C (158 °F)

4.3 Mechanical Tests

except .EF cameras

Environmental Testing	Standard	Parameter	
Vibration, sinussodial	IEC 60068-2-6	Continuous oscillation	10-2000 Hz
		Amplitude underneath cross-over frequencies	0,75 mm
		Acceleration	1 g
		Test duration	150 min (axis) 450 min (total)
Vibration, broad band	IEC 60068-2-64	Frequency range	10-2000 Hz
		Acceleration	10 g
		Test duration	5 h (axis) 15 h (total)
Shock	IEC 60068-2-27	Pulse time	11 ms / 6 ms
		Acceleration	50 g / 100 g
Bump	IEC60068-2-29	Pulse Time	2 ms
		Acceleration	100 g

.EF cameras only

Environmental Testing	Standard	Parameter	
Vibration, broad band	IEC 60068-2-64	Frequency range	5-150 Hz
		Acceleration	0.5 g
		Test duration	5 h (axis) 15 h (total)
Shock	IEC 60068-2-27	Pulse time	30 ms
		Acceleration	5 g

4.4 Lens mounting

Notice

Avoid contamination of the sensor and the lens by dust and airborne particles when mounting the lens to the device!

Therefore the following points are very important:

- Install the camera in an environment that is as dust free as possible!
- Keep the dust cover (bag) on camera as long as possible!
- Hold the camera downwards with unprotected sensor.
- Avoid contact with any optical surface of the camera!



Caution



Do not use grub screws to lock an M58 lens directly to the camera. These can damage the threads of the lens! The grub screws are used only to lock the lens mount adapters.

4.5 Modular tube systems (ordered separately)

4.5.1 Tube Adapter M62

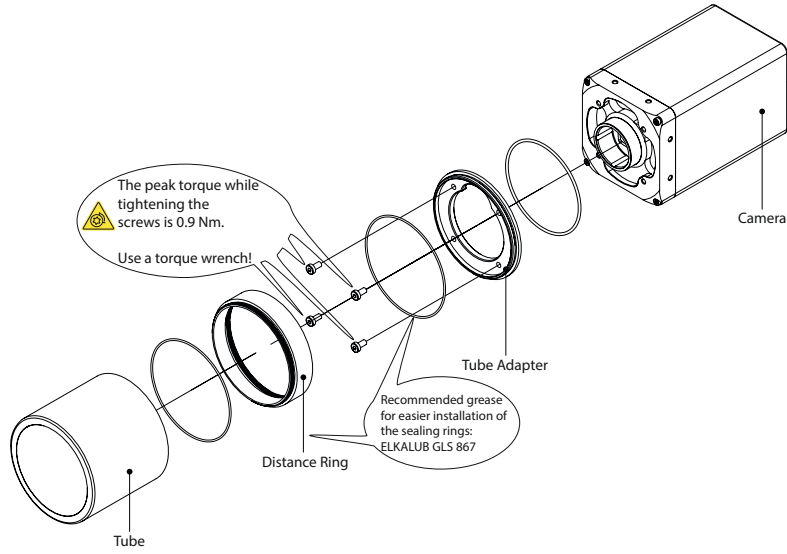

Dimensions M62

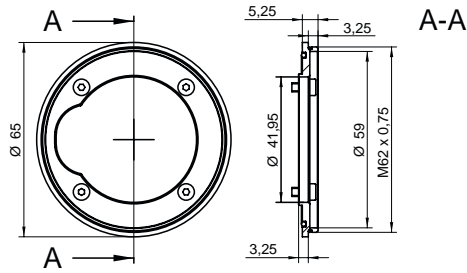

Art. No.: 11193125

Distance Rings M62

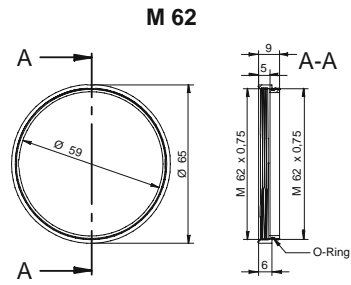

Art. No.: 11185376

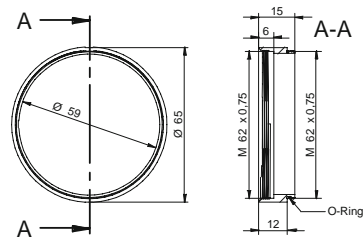

Art. No.: 11185375

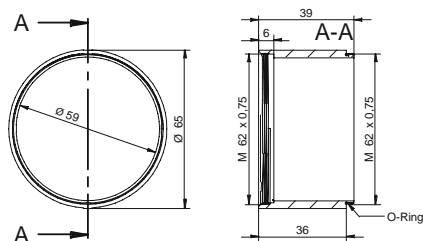

Art. No.: 11198906

Tube M62

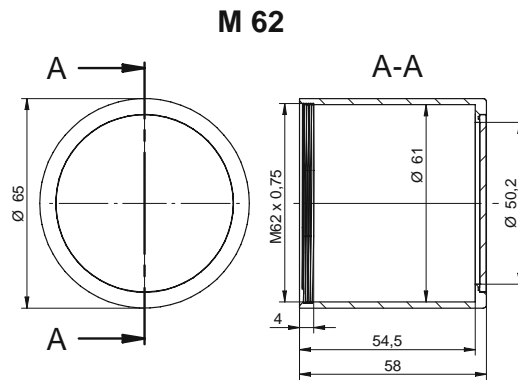

Art. No.: 11185374 / Cover glass: PMMA (Acryl)

Art. No.: 11195426 / Cover glass: resistant laminated safety cover glass

Inner dimensions of the Tube M62

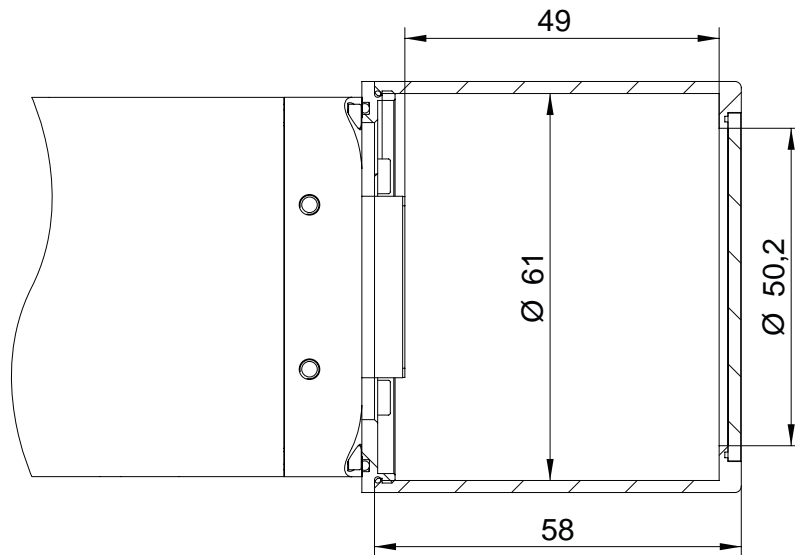

4.5.2 Tube Adapter M92

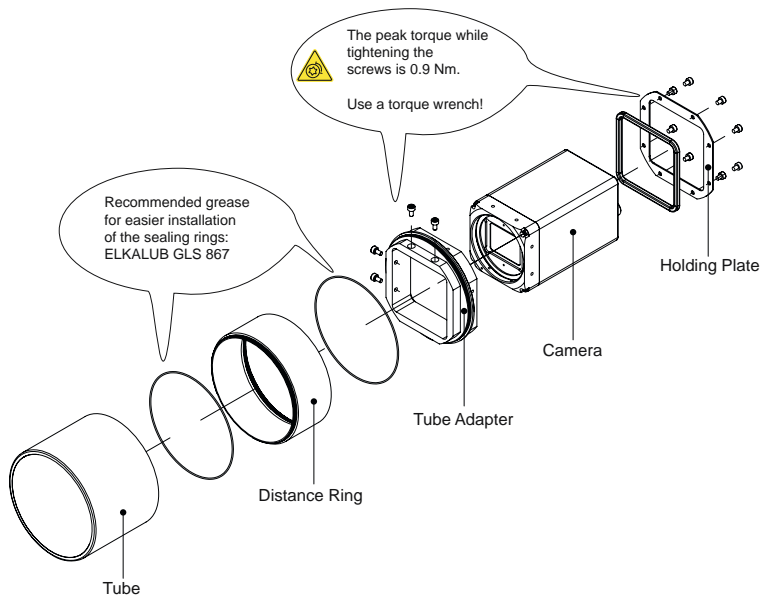

Dimensions

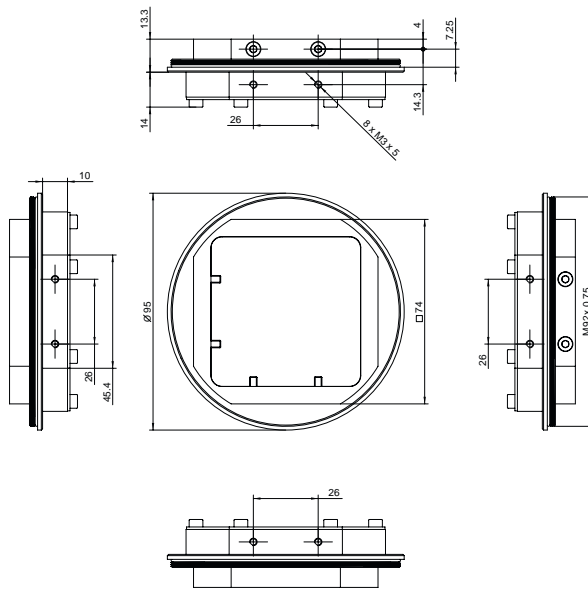

Art. No.: 11704315

Distance Rings

M 92

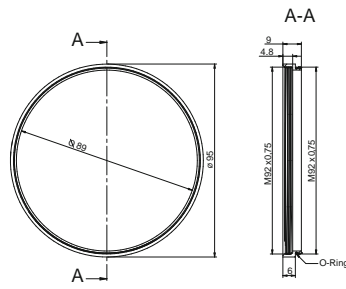

Art. No.: 11704395

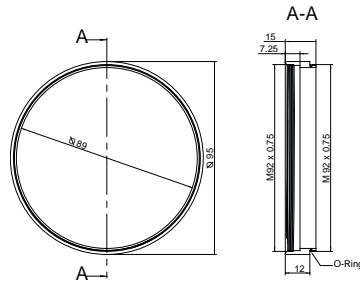

Art. No.: 11704397

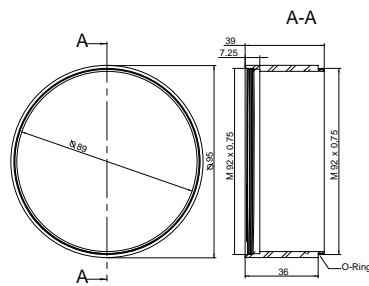

Art. No.: 11704394

Tube M92

M 92

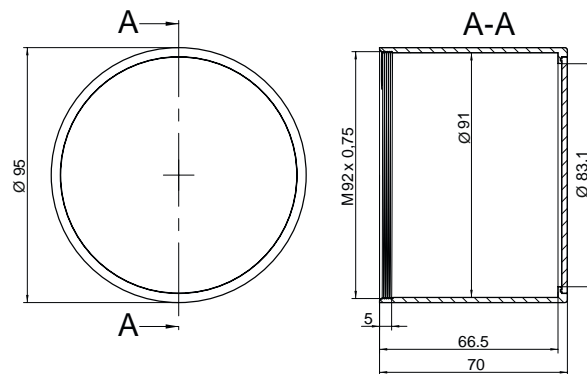

Art. No.: 11704312 / Cover glass: PMMA (Acryl)

4.6 IP Protection classes

The devices continue working in an industrial environment to meet the requirements of various protection classes.

IP40	with mounted lens and 10 GigE cable
IP67	with mounted tube and cable

Notice
The IP Protection classes was not evaluated by UL.

Notice

Definition IP67

IP67 stands for dust tightness besides the protection against submersion into 1 meter deep water for up to 30 minutes. The desired protection level is given as long as the difference in temperature between camera and water is less than 5 K and the water has a temperature of 15 °C (+ 59 °F) ... 35 °C (+ 95 °F).

Caution

In order to achieve the mentioned IP protection level, please note the following information:

- The tube needs to be screwed on gap-free as shown in the figure on the next page.
- The M12 connectors need to be tightened with a torque value of 0.4 Nm. For that Baumer suggests the use of a torque driver (such as Wiha TorqueVario®-S ESD) in combination with a wrench for assembling sensor/actuator cables with M12 connector (such as Phoenix Contact SAC BIT M12-D15).
- Use a cable that also meets the required IP protection class.



VLXT.FO only

On the SFP+ socket, a Harting Adapter and a corresponding cable must be used.

- Harting Adapter: PushPull SFP XS Receptable short, LC Dup (without screws) (item no.: 09574110501200)
- Compatible cable: PP SSFP XS Assy, XSsh-LCdx 50/125 (item no.: 33262310200018)

Sealing rings (M62 Adapter)

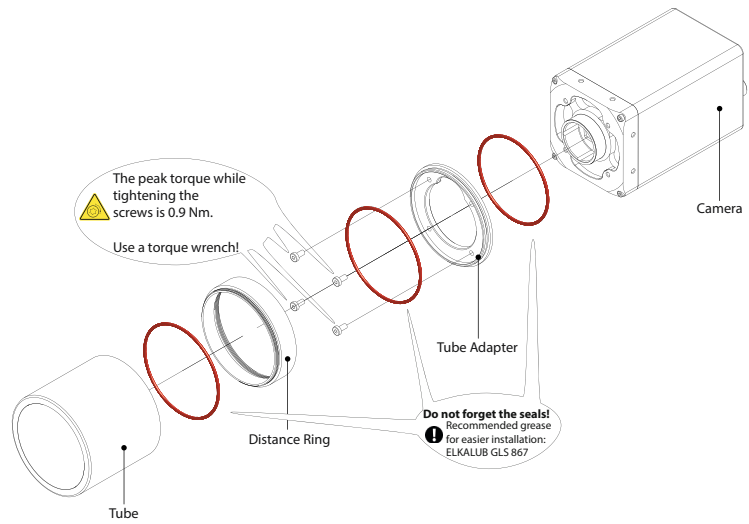

Sealing rings (M92 Adapter)

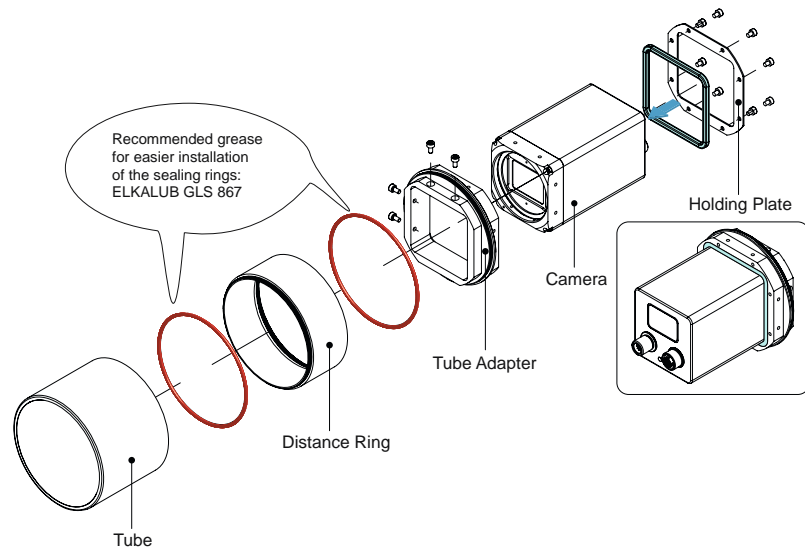

Gap-free assembly

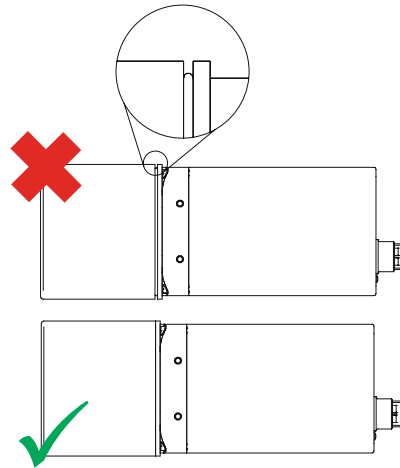

Sealing rings and Harting Adapter (.FO only)

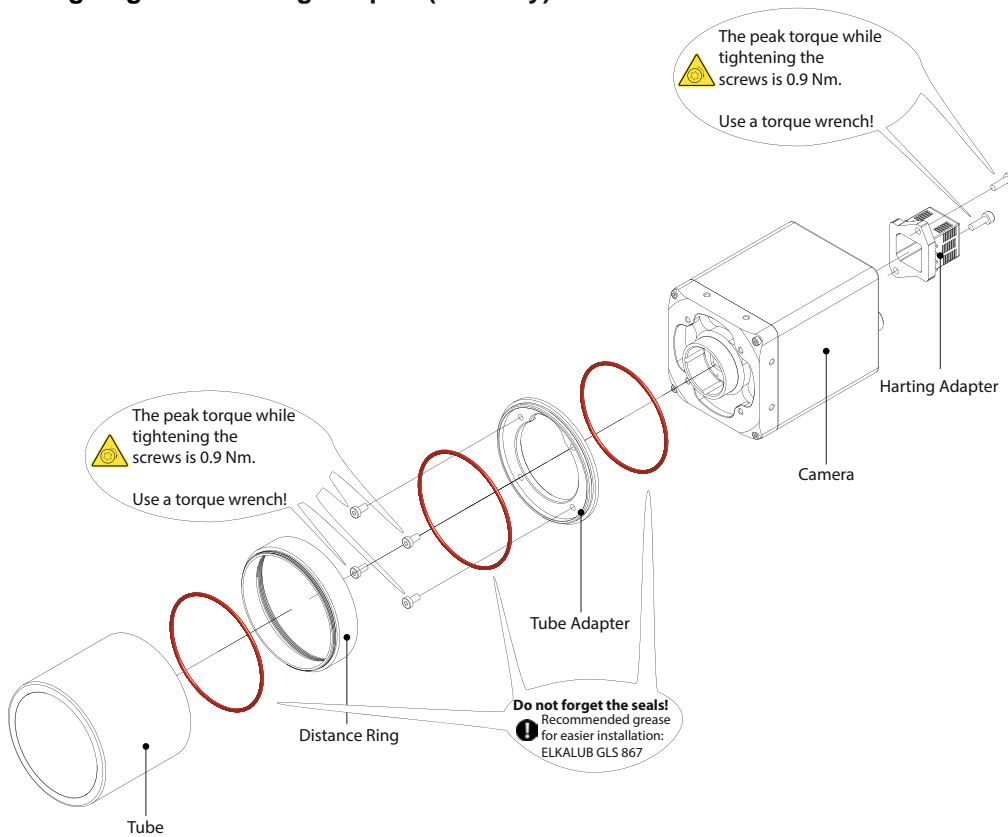

4.7 Cables

For UL conform installations the cables used must meet the following requirements:

- shielding for optimum electrical noise immunity
- IP67 protection
- UL approval
- dielectric strength according to the operating voltages used
- temperature stability in the specified device temperature range
- minimum cross section of cable suitable for max. output current

4.8 Cleaning

Avoid cleaning if possible. To prevent dust build-ups, follow the instructions under *Installation*.

The device requires cleaning if the recorded images resemble the following example. In order to test the camera, capture a homogenous image (test target could be a white sheet of paper).



Filter / Cover glass



Caution!



Use of compressed air during cleaning.

Compressed air may force dust into the camera.

Never use compressed air to clean the filter / cover glass!

Use a soft, lint free cloth dampened with a small amount of pure methanol to clean the filter glass.

Housing



Caution!



Use of volatile solvents for cleaning.

Volatile solvents can damage the surface of the camera.

Never use volatile solvents (benzene, thinner) for cleaning!

Use a soft, dry cloth to clean the surface of the camera housing. To remove persistent stains, use a soft cloth dampened with a small quantity of neutral detergent, then wipe dry.

5. Pin Assignment / LED-Signaling

5.1 VLXT(I) (.EF) (.JP) (10GBASE-T) / VLXN.I.JP (5GBASE-T)

5.1.1 Data Interface

Notice

You can also operate the camera on a slower data interface than 10GigE. This reduces the performance.

Ethernet (SACC-CI-M12FS-8CON-L180-10G)

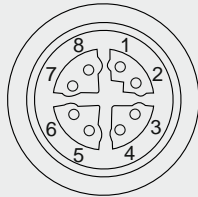

1	MX1+	5	MX4+
2	MX1-	6	MX4-
3	MX2+	7	MX3-
4	MX2-	8	MX3+

Notice

The unit is to be connected only to internal Ethernet networks without exiting a facility and being subjected to Telecom Network Voltages (TNVs).

5.1.2 Power and Process Interface

Power supply / Digital-IO (SACC-CI-M12MS-12CON-L180) wire colors of the connecting cable* (ordered separately)

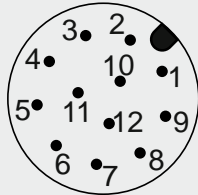

1	Power Vcc	brown	7	OUT3 (Line6)	black
2	GND (Power)	blue	8	RS232 TxD (Line2)	grey
3	IN1 (Line0)	white	9	OUT4 (Line7)	red
4	OUT1 (Line4)	green	10	RS232 RxD (Line3)	violet
5	IN2 (Line1)	pink	11	GND (IO)	grey-pink
6	OUT2 (Line5)	yellow	12	Power (IO)	red-blue

*) shielded cable needs to be used

Notice

Max.Voltage levels RS232 TxD, RS232 RxD line +-15 V. The RS232 interface is controllable by the UART1 value of *boSerialSelector*.

5.1.4 Digital-IO

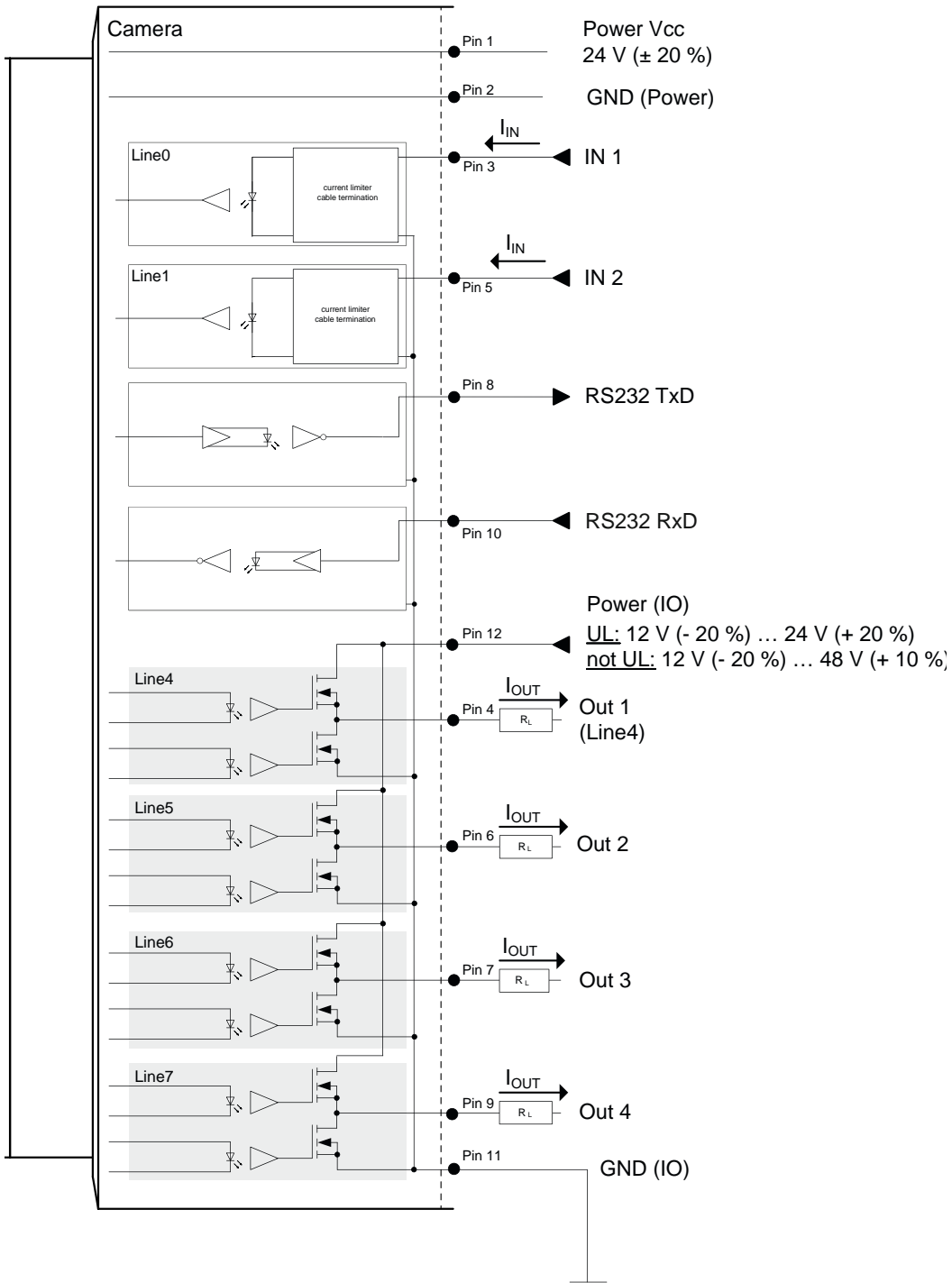

5.1.5 LED Signaling

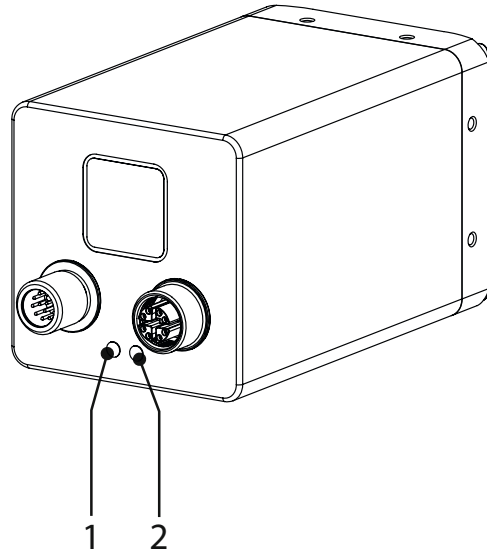

		Signal	Meaning
1	GigE LED	green static	link active
		green flash	receiving
2	Camera LED	yellow static	error
		yellow flash	transmitting
		orange static	overheated

5.2 VLXT.FO (10GBASE-SR/LR)

5.2.1 Data Interface

SFP+ Socket

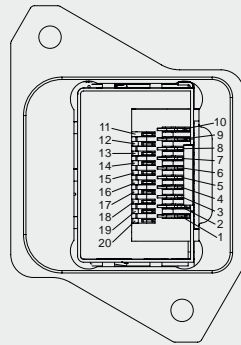

Notice

The unit is to be connected only to internal Ethernet networks without exiting a facility and being subjected to Telecom Network Voltages (TNVs).

1	VEET	11	VEER
2	TX_FAULT	12	RD-
3	TX_DISABLE	13	RD+
4	SDA	14	VEER
5	SCL	15	VCCR
6	MOD_ABS	16	VCCT
7	RS0	17	VEET
8	RX_LOS	18	TD+
9	RS1	19	TD-
10	VEER	20	VEET

5.2.2 Transceiver / Cables

A variety of 10G SFP+ Series Fiber Optic Transceivers and cables available.

Notice

SFP+ modules for GigE (copper) are getting hot and heat the camera.

Only optical SFP+ modules may used which are in compliance with Class I device acc. 21 CFR 1040 (UL).

Please see the compliance list on the Baumer product selector:

<https://www.baumer.com/c/36460/products>

5.2.3 Power and Process Interface

Power supply / Digital-IO (SACC-CI-M12MS-12CON-L180)

wire colors of the connecting cable* (ordered separately)

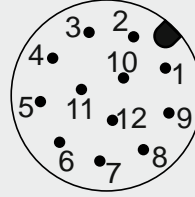

Class 2 per NEC / Protection Class III

The device is intended to be supplied from an isolated Limited Energy Source per UL61010-1, 3rd ed cl. 9.4 or Limited Power Source per UL60950-1 or Class 2 per NEC.

1	Power V _{CC}	brown	7	OUT3 (Line6)	black
2	GND (Power)	blue	8	RS232 TxD (Line2)	grey
3	IN1 (Line0)	white	9	OUT4 (Line7)	red
4	OUT1 (Line4)	green	10	RS232 RxD (Line3)	violet
5	IN2 (Line1)	pink	11	GND (IO)	grey-pink
6	OUT2 (Line5)	yellow	12	Power (IO)	red-blue

^{*)} shielded cable needs to be used

Notice

Max. Voltage levels RS232 TxD, RS232 RxD line +-15 V. The RS232 interface is controllable by the UART1 value of *boSerialSelector*.

Power Supply

Power V _{CC}	12 V ... 24 V (-15 % ... + 20 %) (Power consumption: max. 9.6 W)
Power (IO)	For UL conform installations: 12 V (- 20 %) ... 24 V (+ 20 %) For not UL conform installations: 12 V (- 20 %) ... 48 V (+ 10 %)

5.2.4 UART0 Interface (≥ Release 3 only)

UART0 Interface

(JST BM06B-SRSS-TB)

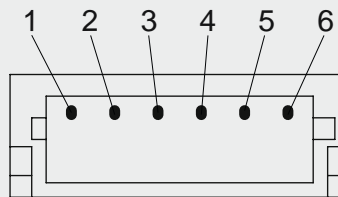

1	Power (UART0)	4	UART TxD
2	GND (UART0)	5	not connected
3	UART RxD	6	not connected

Notice

Please observe the instructions and notes in the technical documentation of the respective lens!

Notice

Serial interface voltage level for UART0 TxD and RxD: 0 V (logical 0) ... 3.3 V (5V tolerant) (logical 1).

This interface is controllable by UART0 value of *boSerialSelector* and is used to control optical components.

5.2.5 Digital-IO

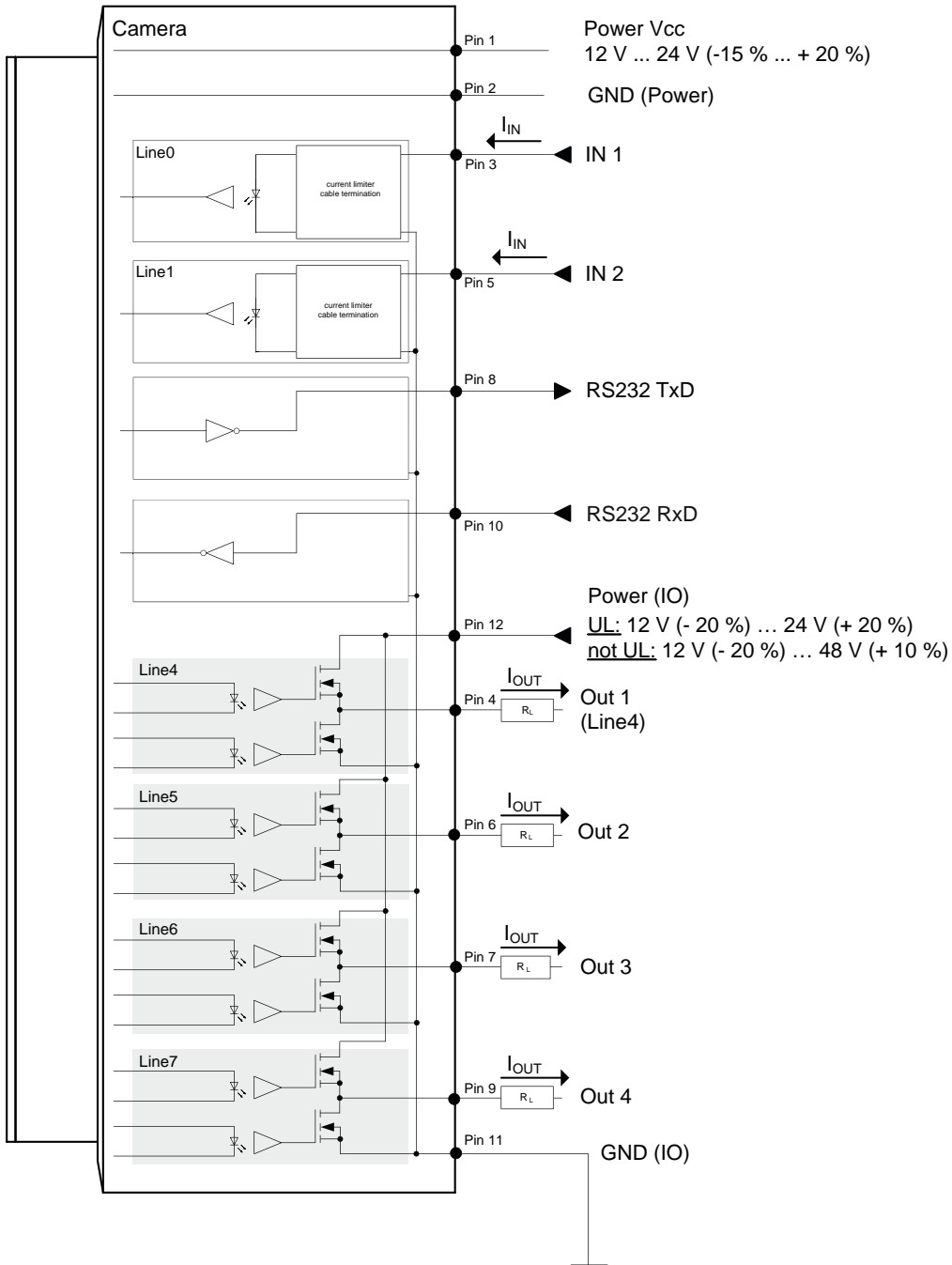

5.2.6 LED Signaling

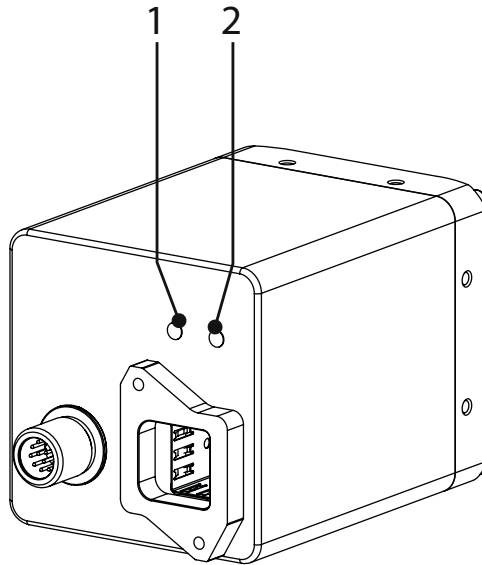

		Signal	Meaning
1	GigE LED	green static	link active
		green flash	receiving
2	Camera LED	yellow static	error
		yellow flash	transmitting
		orange static	overheated

6. Product Specifications

6.1 Spectral Sensitivity

The following graphs show the spectral sensitivity characteristics of the camera. The characteristic curves for the sensors do not take the characteristics of lenses and light sources without filters into consideration.

Values relating to the respective technical data sheets of the sensor.

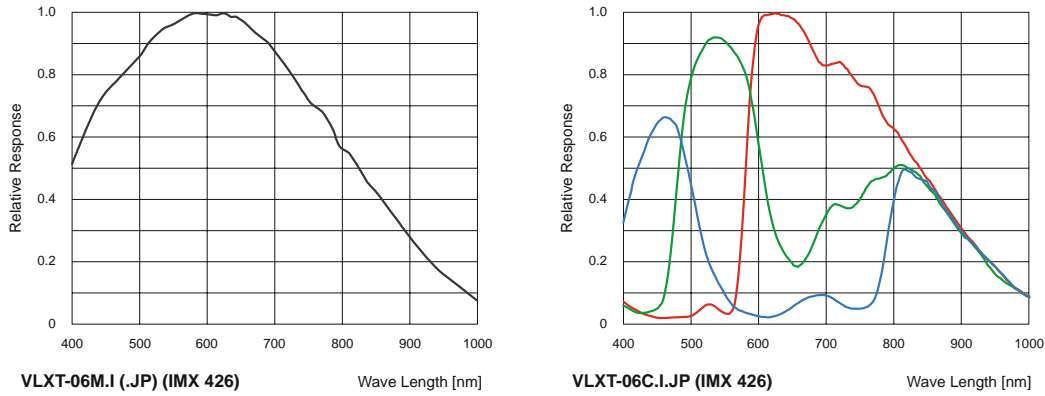

Figure 1: Spectral sensitivities for Baumer cameras with 0.5 MP sensor.

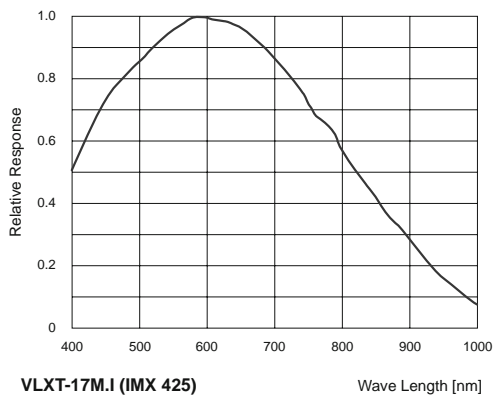

Figure 2: Spectral sensitivities for Baumer cameras with 1.7 MP sensor.

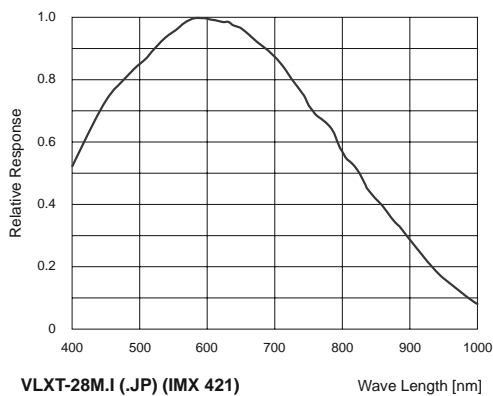

Figure 3: Spectral sensitivities for Baumer cameras with 2.8 MP sensor.

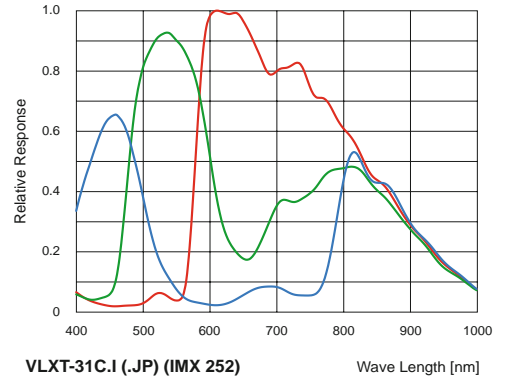
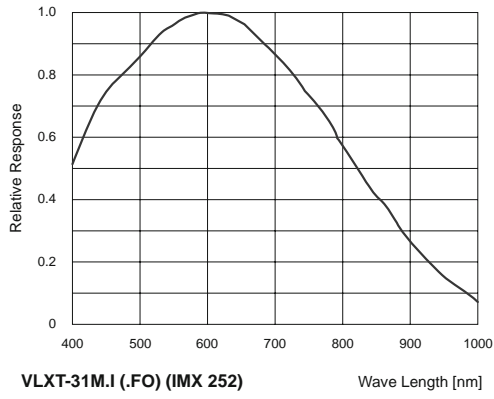

Figure 4: Spectral sensitivities for Baumer cameras with 3.1 MP sensor.

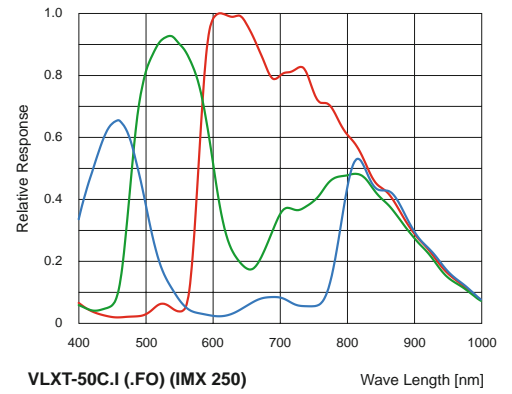
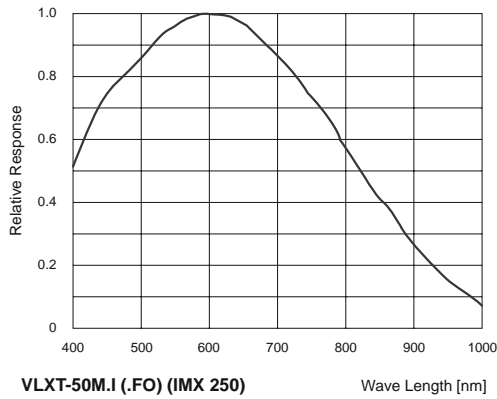

Figure 5: Spectral sensitivities for Baumer cameras with 5.0 MP sensor.

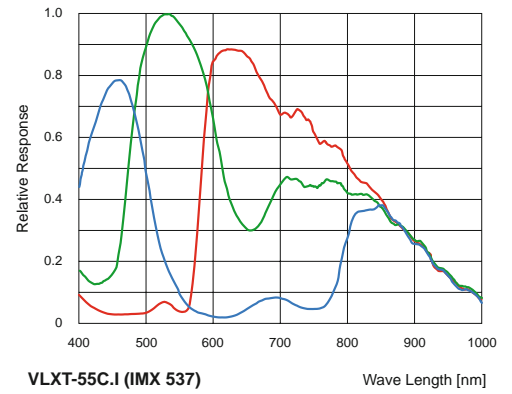
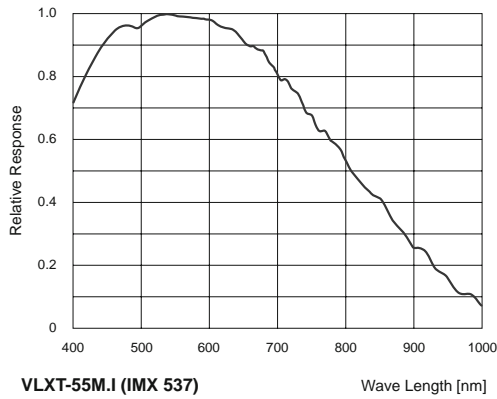

Figure 6: Spectral sensitivities for Baumer cameras with 5.0 MP sensor.

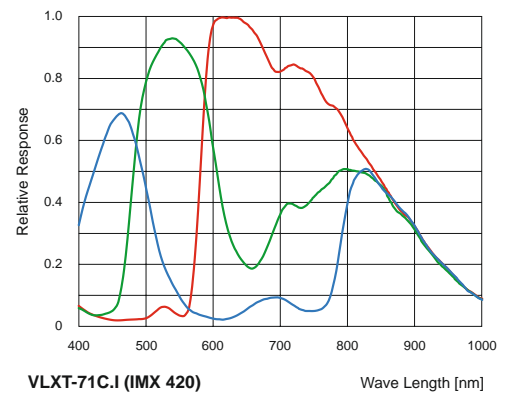
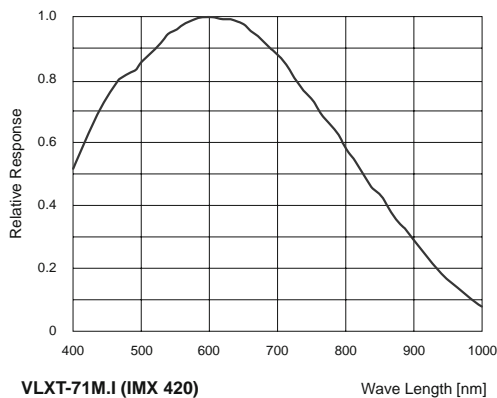

Figure 7: Spectral sensitivities for Baumer cameras with 7.1 MP sensor.

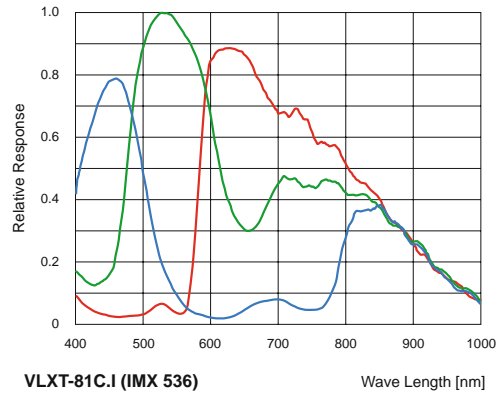
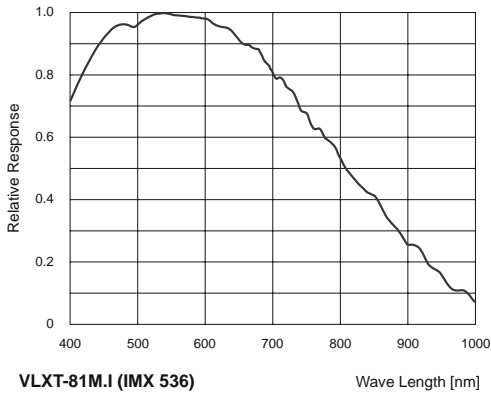
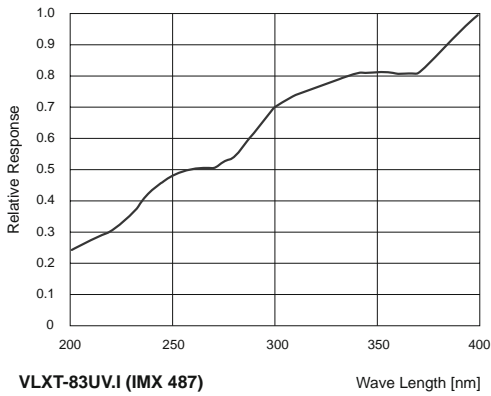

Figure 8: Spectral sensitivities for Baumer cameras with 8.0 MP sensor.



Notice
 Sony® IMX 487 is designed for only UV wavelength (200 nm - 400 nm). In visible wavelength, image quality is not assured.

Figure 9: Spectral sensitivities for Baumer cameras with 8.0 MP UV sensor.

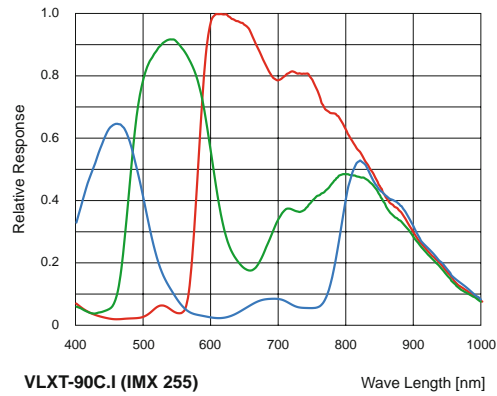
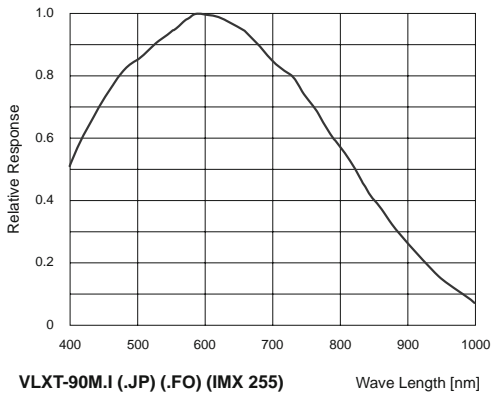

Figure 10: Spectral sensitivities for Baumer cameras with 9.0 MP sensor.

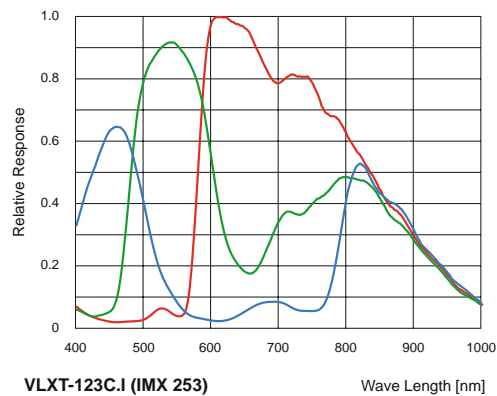
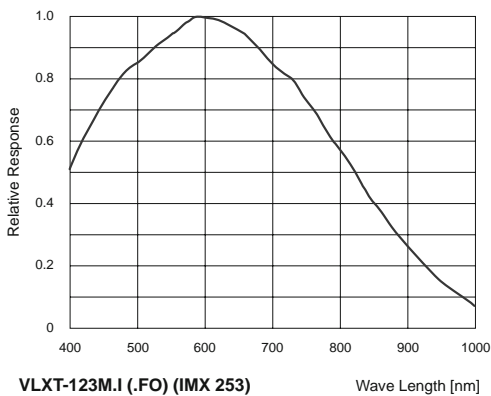

Figure 11: Spectral sensitivities for Baumer cameras with 12.3 MP sensor.

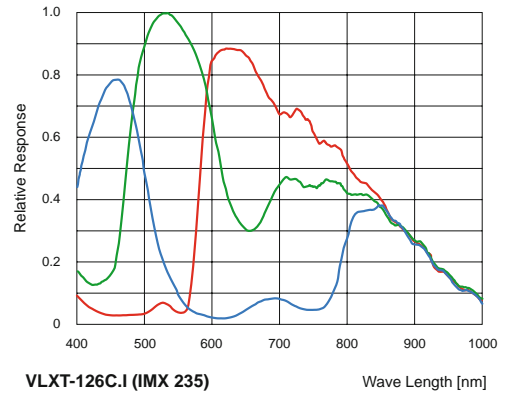
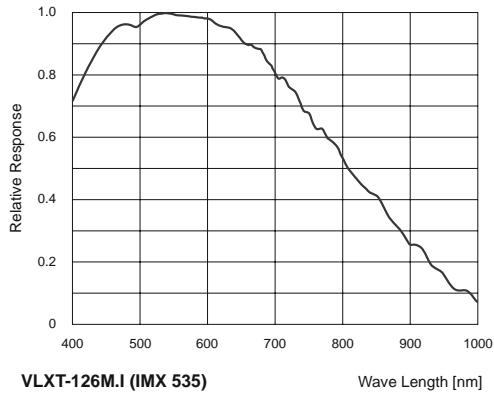

Figure 12: Spectral sensitivities for Baumer cameras with 12.6 MP sensor.

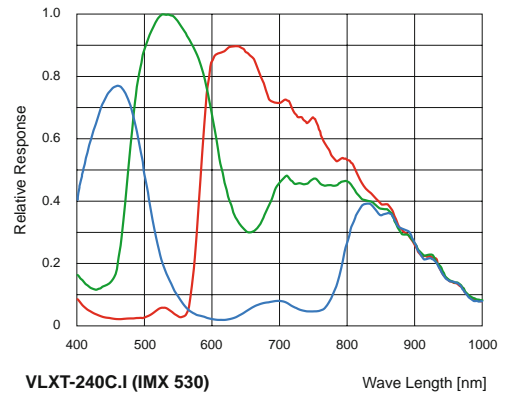
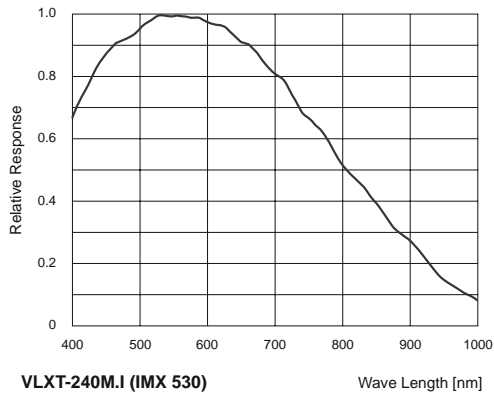

Figure 13: Spectral sensitivities for Baumer cameras with 24.4 MP sensor.

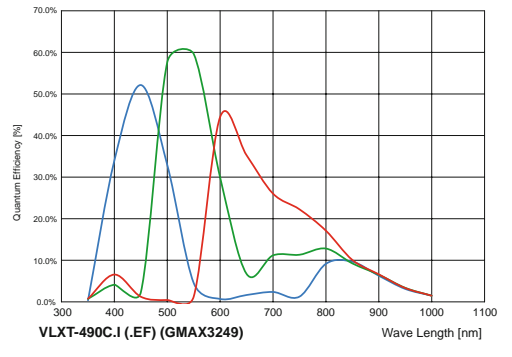
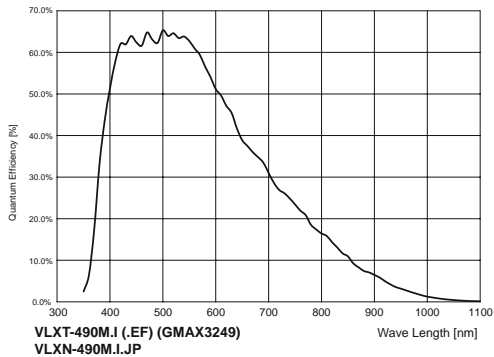

Figure 14: Spectral sensitivities for Baumer cameras with 49 MP sensor.

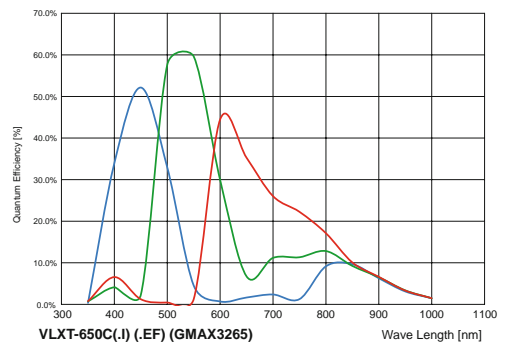
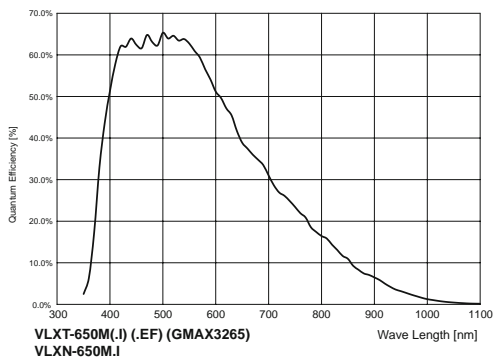
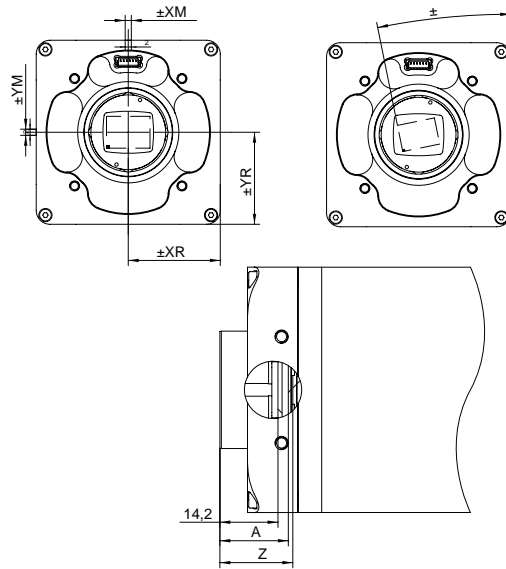

Figure 15: Spectral sensitivities for Baumer cameras with 12.3 MP sensor.

6.2 Sensor position accuracy

The typical accuracy by assumption of the root mean square value is displayed in the figures and the table below:

C- / TFL-Mount



M58-Mount

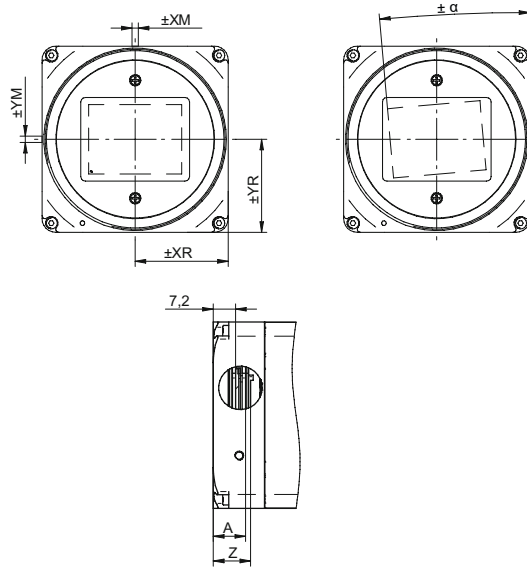

EF-Mount

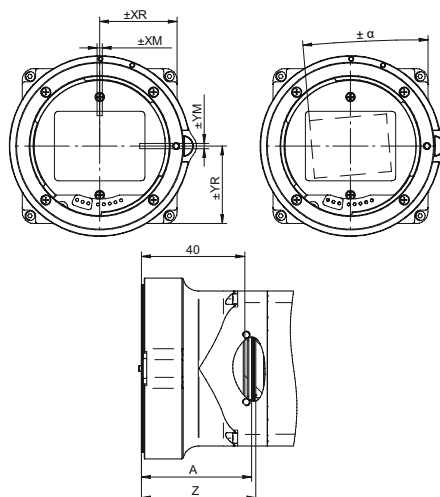

typical accuracy by assumption of the root mean square value

* C or M

** Dimension D in this table is from manufacturer datasheet

*** for color add 0.35 mm to normal value

Camera Type	$\pm X_M$ [mm]	$\pm Y_M$ [mm]	$\pm X_R$ [mm]	$\pm Y_R$ [mm]	Z^{***}_{typ} [mm]	$\pm \alpha_{typ}$ [°]	A^{***} [mm]	D^{**} [mm]
VLXT-06*	0,05	0,05	0,05	0,05	17,53 ±0,05	0,25	15,6	0,5
VLXT-17*	0,05	0,05	0,05	0,05	17,53 ±0,05	0,25	15,6	0,5
VLXT-28*	0,05	0,05	0,05	0,05	17,53 ±0,05	0,25	15,6	0,5
VLXT-31*	0,14	0,14	0,15	0,15	17,53 ±0,05	0,5	16,33	0,7
VLXT-50*	0,14	0,14	0,15	0,15	17,53 ±0,05	0,5	16,33	0,7
VLXT-55*	0,05	0,05	0,05	0,05	17,53 ±0,05	0,25	15,6	0,5
VLXT-71*	0,05	0,05	0,05	0,05	17,53 ±0,05	0,25	15,6	0,5
VLXT-81*	0,05	0,05	0,05	0,05	17,53 ±0,05	0,25	15,6	0,5
VLXT-90*	0,1	0,1	0,11	0,11	17,53 ±0,05	0,5	16,33	0,7
VLXT-123*	0,1	0,1	0,11	0,11	17,53 ±0,05	0,5	16,33	0,7
VLXT-126*	0,05	0,05	0,05	0,05	17,53 ±0,05	0,25	15,6	0,5
VLXT-240*	0,05	0,05	0,05	0,05	17,53 ± 0,05	0,07	15,8	0,5
VLXT-490*	0,11	0,10	0,11	0,10	12 ± 0,25	0,13	10,45	0,9
VLXT-650*	0,11	0,10	0,11	0,10	12 ± 0,25	0,13	10,45	0,9

6.3 Software

6.3.1 Baumer GAPI

Baumer GAPI stands for **Baumer “Generic Application Programming Interface”**. With this API Baumer provides an interface for quick and easy integration of Baumer industrial cameras using C++, C, and C# (Windows only). This software interface allows changing to other camera models.

This API supports Windows, Linux and ARM-based platforms.

More information can be found at: www.baumer.com/vision/software

6.3.2 NeoAPI

The NeoAPI is a powerful, user-friendly API for camera integration. It allows quick integration of Baumer cameras in C++, C#, and Python with only a few lines of code.

This API supports Windows, Linux and ARM-based platforms.

More information can be found at: www.baumer.com/neoAPI

6.3.3 3rd Party Software

Strict compliance with the GenICam™ standard allows Baumer to offer the use of 3rd Party Software for operation with cameras of this series.

You can find a current listing of 3rd Party Software, which was tested successfully in combination with Baumer cameras, at: <https://www.baumer.com/c/14180>

7. Camera Functions

The camera features are represented by a GenICam™ compliant XML description file. The following chapter describes all available features included there. Most of the camera's features are standardized in the GenICam™ SFNC and must use the name defined there. Specialized features not mapping to an existing GenICam™ SFNC name are included as vendor-specific within the 'Custom' namespace.

The camera features are functional grouped by Category features. This elements can be used by software to display the features in more organized way.

Notice

Not all features listed here are supported by every camera.

You can view the functionality of your camera in the feature widget **1** of the *Camera Explorer*.

Please refer to the appropriate documentation.

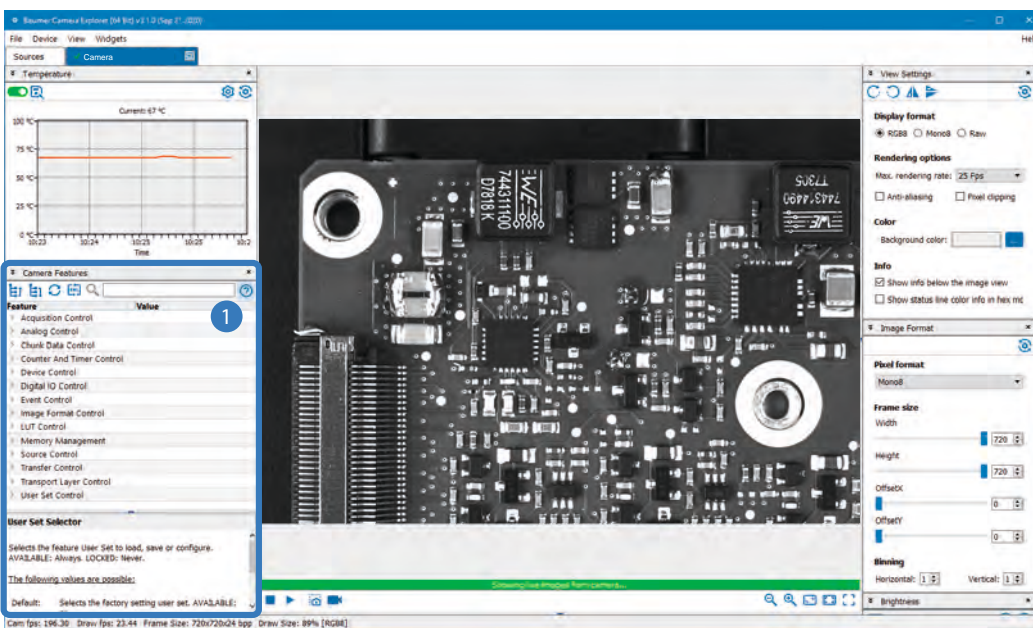

7.1 Category: AcquisitionControl

This chapter describes all features related to image acquisition, including the trigger and exposure control.

7.1.1 AcquisitionAbort

The acquisition abort process is a special case in which the current acquisition is stopped. If an exposure is running, the exposure is aborted immediately and the image is not read out.

Name	AcquisitionAbort
Category	AcquisitionControl
Interface	ICommand
Access	Write only
Unit	-
Values	-

7.1.2 AcquisitionFrameCount

Number of frames to acquire in MultiFrame Acquisition mode

Name	AcquisitionFrameCount
Category	AcquisitionControl
Interface	IInteger
Access	Read / Write
Unit	-
Values	1 - 65535 (Increment: 1)

7.1.3 AcquisitionFrameRate

Controls the acquisition rate (in Hertz) at which the frames are captured.

Notice

For cameras that use the PTP functionality, the generation of the frame rate is based on the synchronized timestamp. This ensures the synchronous recording of frames.

To use this functionality, set *PtpServoStatus = Locked*.

Name	AcquisitionFrameRate
Category	AcquisitionControl
Interface	IFloat
Access	Read / Write
Unit	Hz
Values	depends on camera

7.1.4 AcquisitionFrameRateEnable

Enables the acquisition at the framerate specified by AcquisitionFrameRate.

Name	AcquisitionFrameRateEnable
Category	AcquisitionControl
Interface	IBoolean
Access	Read / Write
Unit	-
Values	true = 1 (On)
	false = 0 (Off)

7.1.5 AcquisitionMode

Sets the acquisition mode of the device. It defines mainly the number of frames to capture during an acquisition and the way the acquisition stops.

Notice

The camera must be stopped before this feature can be edited.

Name	AcquisitionMode	
Category	AcquisitionControl	
Interface	IEnumeration	
Access	Read / Write	
Unit	-	
Values	Continuous	Frames are captured continuously without external events until stopped with the AcquisitionStop command.
	MultiFrame	In this mode a predefined number of frames will be captured after AcquisitionStart. The AcquisitionFrameCount controls the number of captured frames. Then the acquisition is automatically stopped.
	SingleFrame	In this mode the camera is captured one frame after AcquisitionStart. Then the acquisition is stopped.

7.1.6 AcquisitionStart

Once image acquisition has started, the camera processes the images in three steps:

- Determining the current set of image parameters
- Sensor exposure
- Readout from the sensor.

This process is then repeated until the camera is stopped.

Notice

Certain settings which affect the image format can only be adjusted if the camera is stopped.

This includes:

- PixelFormat
- Region of Interest (OffsetX / OffsetY / Width / Height)

Name	AcquisitionStart
Category	AcquisitionControl
Interface	ICommand
Access	Write only
Unit	-
Values	-

7.1.7 AcquisitionStatus

Reads the state of the internal acquisition signal selected using *AcquisitionStatusSelector*.

Name	AcquisitionStatus
Category	AcquisitionControl
Interface	IBoolean
Access	Read only
Unit	-
Values	true = 1 (On) false = 0 (Off)

7.1.8 AcquisitionStatusSelector

Selects the internal acquisition signal to read using AcquisitionStatus.

Name	AcquisitionStatusSelector
Category	AcquisitionControl
Interface	IEnumeration
Access	Read / Write
Unit	-
Values	Acquisition Active Device is currently doing an acquisition of one or many frames. Acquisition Trigger Wait Device is currently waiting for a trigger for the capture of one or many frames.

7.1.9 AcquisitionStop

Stops the Acquisition of the device at the end of the current Frame.

Name	AcquisitionStop
Category	AcquisitionControl
Interface	ICommand
Access	Write only
Unit	-
Values	-

7.1.10 ExposureAuto (≥ Release 2 only)

Sets the automatic exposure mode when ExposureMode is Timed. The exact algorithm used to implement this control is device-specific.

Name	ExposureAuto	
Category	AcquisitionControl	
Interface	IEnumeration	
Access	Read / Write	
Unit	-	
Values	Continuous	Exposure duration is constantly adapted by the device to maximize the dynamic range.
	Off	Exposure duration is user controlled using Exposure-Time.
	Once	Exposure duration is adapted once by the device. Once it has converged, it returns to the Off state.

7.1.11 ExposureMode

Sets the operation mode of the Exposure (or shutter).

Name	ExposureMode	
Category	AcquisitionControl	
Interface	IEnumeration	
Access	Read / Write	
Unit	-	
Values	Timed	Timed exposure. The exposure duration time is set using the ExposureTime or ExposureAuto features and the exposure starts with the FrameStart or LineStart.

7.1.12 ExposureTime

On exposure of the sensor, the inclination of photons produces a charge separation on the semiconductors of the pixels. This results in a voltage difference which is used to extract the signal.

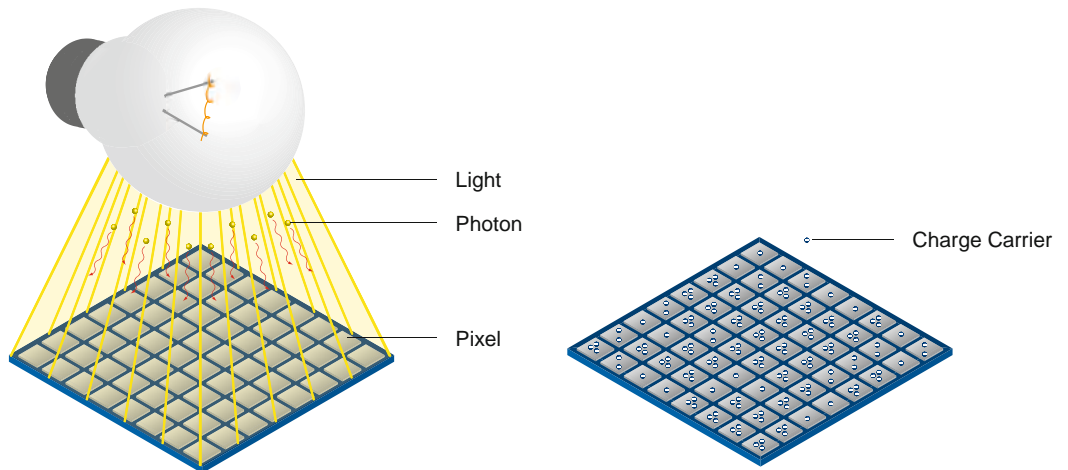

The signal strength is influenced by the incoming amount of photons. It can be increased by increasing the exposure time (t_{exposure}).

Name	ExposureTime
Category	AcquisitionControl
Interface	IFloat
Access	Read / Write
Unit	μs
Values	see table below

Notice

It is not possible to use the *Sequencer* when the feature *Short Exposure Time Enable* is enabled.

Notice

If the feature *ShortExposureTimeEnable* is enabled and the exposure time is changed e.g. from 20 μs to lower than 15 μs , this will change the internal parameters of the sensors and the sensor needs to reinitialize.

This initialization sequence takes about 50 ms. This process is only necessary, if the exposure range is changed. If the new exposure value is within the default exposure range, no initialization is necessary.

Camera Type	$t_{\text{exposure min}}$ <small>ExposureTimeDefault ShortExposureTimeEnable</small>	$t_{\text{non-selectable range}}^*$ <small>ExposureTimeGapMin - ExposureTimeGapMax</small>	$t_{\text{exposure max}}$
Monochrome			
VLXT-06M.I (.JP)	7 1 μs	6 μs	60 s
VLXT-17M.I	7 1 μs	6 μs	60 s
VLXT-31M(.I) (.FO)	15 1 μs		60 s
VLXT-28M.I (.JP)	8 1 μs	6 - 7 μs	60 s
VLXT-50M(.I) (.FO)	15 1 μs		60 s
VLXT-55M.I	5 1 μs	4 μs	60 s
VLXT-71M.I	9 1 μs	6 - 8 μs	60 s
VLXT-81M.I	6 1 μs		60 s
VLXT-83UV.I	6 1 μs		60 s
VLXT-90M (.I) (.JP) (.FO)	15 1 μs		60 s
VLXT-123M(.I) (.FO)	15 1 μs		60 s
VLXT-126M.I	7 1 μs	4 - 6 μs	60 s
VLXT-240M.I	8 1 μs		60 s
VLXT-490M.I (.EF)			60 s
VLXN-490M.I.JP	20 μs		60 s
VLXT-650M.I (.EF)			60 s
VLXN-650M.I.JP	20 μs		60 s
Color			
VLXT-06C.I.JP	7 1 μs	6 μs	60 s
VLXT-31C.I (.JP)	15 1 μs		60 s
VLXT-50C(.I) (.FO)	15 1 μs		60 s
VLXT-55C.I	5 1 μs	4 μs	60 s
VLXT-71C.I	9 1 μs	6 - 8 μs	60 s
VLXT-81C.I	6 1 μs	6 - 8 μs	60 s
VLXT-90C.I	15 1 μs		60 s
VLXT-123C.I	15 1 μs		60 s
VLXT-126C.I	7 1 μs	4 - 6 μs	60 s
VLXT-240C.I	8 1 μs		60 s
VLXT-490C.I (.EF)	20 μs		60 s
VLXT-650C.I (.EF)	20 μs		60 s

^{*)} range only relevant with activated *ShortExposureTimeEnable*

Notice

If the `ExposureTime` is within the gap range ($t_{\text{non-selectable range}}^*$), a value of `ExposureTimeGapMax + 1` is automatically set.

7.1.13 ExposureTimeGapMax (≥ Release 3 only)

Returns the maximum value of the exposure time gap.

Name	ExposureTimeGapMax
Category	AcquisitionControl
Interface	IFloat
Access	Read only
Unit	μs
Values	0 - 2,000,000.000000 (Increment: 1.00)

7.1.14 ExposureTimeGapMin (≥ Release 3 only)

Returns the minimum value of the exposure time gap.

Name	ExposureTimeGapMin
Category	AcquisitionControl
Interface	IFloat
Access	Read only
Unit	μs
Values	0 - 2,000,000.000000 (Increment: 1.00)

7.1.15 ReadoutMode

Specifies the operation mode of the readout for the acquisition.

Image acquisition consists of two separate procedures carried out in succession.

Exposing the pixels on the photosensitive surface of the sensor is only the first part of the image acquisition process. Once this first step is completed, the pixels are read out.

The exposure time (t_{exposure}) can be adjusted by the user, however, the time needed for the readout (t_{readout}) is determined by the particular sensor and image format in use.

The cameras can be operated sequential or overlapped depending on the mode and the combination of exposure and readout times used:

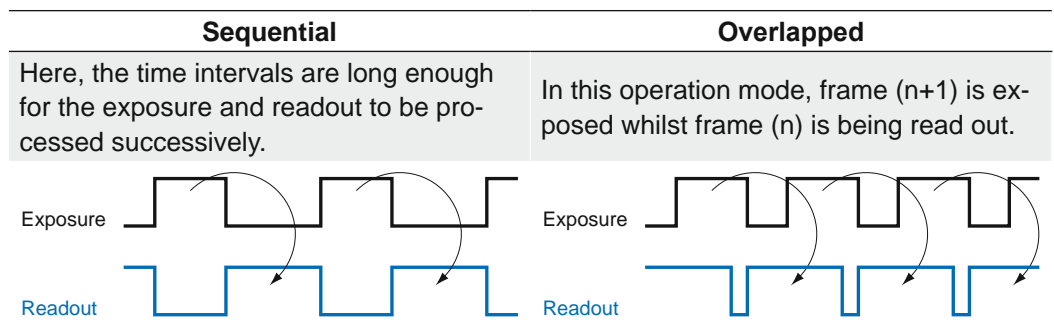

Name	ReadoutMode	
Category	AcquisitionControl	
Interface	IEnumeration	
Access	Read / Write	
Unit	-	
Values	Overlapped	Overlapped ReadoutMode
	Sequential	Sequential ReadoutMode

7.1.16 ShortExposureTimeEnable

Controls if short exposure time should be supported.

Notice

It is not possible to use the *Sequencer* when the feature *Short Exposure Time Enable* is enabled.

Name	ShortExposureTimeEnable
Category	AcquisitionControl
Interface	IBoolean
Access	Read / Write
Unit	-
Values	true = 1 (On) false = 0 (Off)

7.1.17 TriggerActivation

Specifies the activation mode of the trigger.

Name	TriggerActivation
Category	AcquisitionControl
Interface	IEnumeration
Access	Read / Write
Unit	-
Values	FallingEdge Specifies that the trigger is considered valid on the falling edge of the source signal. RisingEdge Specifies that the trigger is considered valid on the rising edge of the source signal.

7.1.18 TriggerDelay

Specifies the delay in microseconds (us) to apply after the trigger reception before activating it.

Name	TriggerDelay
Category	AcquisitionControl
Interface	IFloat
Access	Read / Write
Unit	µs
Values	0 - 2,000,000.000000 (Increment: 1.00)

7.1.19 TriggerMode

Controls if the selected trigger is active.

Name	TriggerMode	
Category	AcquisitionControl	
Interface	IEnumeration	
Access	Read / Write	
Unit	-	
Values	Off	Disables the selected trigger.
	On	Enable the selected trigger.

7.1.20 TriggerOverlap

Specifies the type trigger overlap permitted with the previous frame.

Name	TriggerOverlap	
Category	AcquisitionControl	
Interface	IEnumeration	
Access	Read / Write	
Unit	-	
Values	Read Out	Trigger is accepted immediately after the exposure period..

7.1.21 TriggerSelector

Selects the type of trigger to configure.

Name	TriggerSelector	
Category	AcquisitionControl	
Interface	IEnumeration	
Access	Read / Write	
Unit	-	
Values	Frame Start	Selects the type of trigger to configure.

7.1.22 TriggerSoftware

Generates a internal trigger. *TriggerSource* must be set to Software.

Name	TriggerSoftware	
Category	AcquisitionControl	
Interface	ICommand	
Access	Write only	
Unit	-	
Values	-	

7.1.23 TriggerSource

Specifies the internal signal or physical input Line to use as the trigger source. The selected trigger must have its *TriggerMode* set to On.

Name	TriggerSource	
Category	AcquisitionControl	
Interface	IEnumeration	
Access	Read / Write	
Unit	-	
Values	Action1	Specifies which Action command to use as internal source for the trigger.
	All	All trigger sources are active.
	Counter1End (≥ Rel. 2 only)	Specifies which of the Counter signal to use as internal source for the trigger.
	Counter2End (≥ Rel. 2 only)	Specifies which of the Counter signal to use as internal source for the trigger.
	Line0	Specifies which physical line (or pin) and associated I/O control block to use as external source for the trigger signal.
	Line1	Specifies which physical line (or pin) and associated I/O control block to use as external source for the trigger signal.
	Off	No trigger source is active.
	Software	Specifies that the trigger source will be generated by software using the TriggerSoftware command.

7.2 Category: ActionControl

Category that contains the Action control features.

7.2.1 ActionDeviceKey

Provides the device key that allows the device to check the validity of action commands. The device internal assertion of an action signal is only authorized if the *ActionDeviceKey* and the action device key value in the protocol message are equal.

Name	ActionDeviceKey
Category	AnalogControl
Interface	Integer
Access	Write only
Unit	-
Values	0 - 4294967295 (Increment: 1)

7.2.2 ActionGroupKey

Provides the key that the device will use to validate the action on reception of the action protocol message.

Name	ActionGroupKey
Category	AnalogControl
Interface	Integer
Access	Read / Write
Unit	-
Values	0 - 4294967295 (Increment: 1)

7.2.3 ActionGroupMask

Provides the mask that the device will use to validate the action on reception of the action protocol message.

Name	ActionGroupMask
Category	AnalogControl
Interface	Integer
Access	Read / Write
Unit	-
Values	0 - 4294967295 (Increment: 1)

7.2.4 ActionSelector

Selects to which Action Signal further Action settings apply.

Name	ActionSelector
Category	AnalogControl
Interface	IInteger
Access	Read / Write
Unit	-
Values	1 - 1 (Increment: 1)

7.3 Category: AnalogControl

Features in this chapter describes how to influence the analog features of an image, such as gain, black level, brightness correction and gamma.

7.3.1 BalanceWhiteAuto (color cameras only)

Controls the mode for automatic white balancing between the color channels. The white balancing ratios are automatically adjusted.

Name	BalanceWhiteAuto	
Category	AnalogControl	
Interface	IEnumeration	
Access	Read / Write	
Unit	-	
Values	Continuous	White balancing is constantly adjusted by the device.
	Off	White balancing is off.
	Once	White balancing is automatically adjusted once by the device. Once it has converged, it automatically returns to the Off state.

7.3.2 BlackLevel

Controls the analog black level as an absolute physical value. This represents a DC offset applied to the video signal.

Name	BlackLevel
Category	AnalogControl
Interface	IFloat
Access	Read / Write
Unit	-
Values	see table below (Increment: 1.00)

Camera Type	Black Level
Monochrome	
VLXT-06M.I (.JP)	0 ... 255 DN12
VLXT-17M.I	0 ... 255 DN12
VLXT-28M.I (.JP)	0 ... 255 DN12
VLXT-31M(.I) (.FO)	0 ... 255 DN12
VLXT-50M(.I) (.FO)	0 ... 255 DN12
VLXT-55M.I	0 ... 255 DN12
VLXT-71M(.I) (.FO)	0 ... 255 DN12
VLXT-81M.I	0 ... 255 DN12
VLXT-83UV.I	0 ... 255 DN12
VLXT-90M(.I) (.JP) (.FO)	0 ... 255 DN12
VLXT-123M(.I) (.FO)	0 ... 255 DN12
VLXT-126M.I	0 ... 255 DN12
VLXT-240M.I	0 ... 255 DN12
VLXT-490M.I (.EF)	0 ... 255 DN12
VLXN-490M.I.JP	0 ... 255 DN12
VLXT-650M.I (.EF)	0 ... 255 DN12
VLXN-650M.I.JP	0 ... 255 DN12
Color	
VLXT-06C.I.JP	0 ... 255 DN12
VLXT-31C.I (.JP)	0 ... 255 DN12
VLXT-50C(.I) (.FO)	0 ... 255 DN12
VLXT-55C.I	0 ... 255 DN12
VLXT-71C.I	0 ... 255 DN12
VLXT-81C.I	0 ... 255 DN12
VLXT-90C.I	0 ... 255 DN12
VLXT-123C.I	0 ... 255 DN12
VLXT-126C.I	0 ... 255 DN12
VLXT-240C.I	0 ... 255 DN12
VLXT-490C.I (.EF)	0 ... 255 DN12
VLXT-650C.I (.EF)	0 ... 255 DN12

7.3.3 BlackLevelSelector

Selects which Black Level is controlled by the various Black Level features.

Name	BlackLevelSelector
Category	AnalogControl
Interface	IEnumeration
Access	Read / Write
Unit	-
Values	All Black Level will be applied to all channels or taps.

7.3.4 Gain

Motion blur is unacceptable in high quality image acquisition. Exposure times are therefore limited. However, this results in low output signals from the camera and dark images. To solve this issue, the signals can be amplified by a user-defined gain factor within the camera.

Notice

Increasing the gain factor also increases image noise.

Controls the selected gain as an absolute physical value.

Name	Gain
Category	AnalogControl
Interface	IIFloat
Access	Read / Write
Unit	-
Values	see table below

Camera Type	Gain [db]
Monochrome	
VLXT-06M.I (.JP)	0...48
VLXT-17M.I	0...48
VLXT-28M.I (.JP)	0...48
VLXT-31M(.I) (.FO)	0...48
VLXT-50M(.I) (.FO)	0...48
VLXT-55M.I	0...48
VLXT-71M.I	0...48
VLXT-81M.I	0...48
VLXT-83UV.I	0...48
VLXT-90M(.I) (.JP) (.FO)	0...48
VLXT-123M(.I) (.FO)	0...48
VLXT-126M.I	0...48
VLXT-240M.I	0...48
VLXT-490M.I	0...48
VLXN-490M.I.JP	
VLXT-650M.I (.EF)	0...48
VLXN-650M.I.JP	

Camera Type	Gain [db]
Color	
VLXT-06C.I.JP	0...48
VLXT-31C.I (.JP)	0...48
VLXT-50C(.I) (.FO)	0...48
VLXT-55C.I	0...48
VLXT-71C.I	0...48
VLXT-81C.I	0...48
VLXT-90C.I	0...48
VLXT-123C.I	0...48
VLXT-126C.I	0...48
VLXT-240C.I	0...48
VLXT-490C.I (.EF)	0...48
VLXT-650C.I (.EF)	0...48

7.3.5 GainAuto (≥ Release 2 only)

Sets the automatic gain control (AGC) mode. The exact algorithm used to implement AGC is device-specific.

Name	GainAuto	
Category	AnalogControl	
Interface	IEnumeration	
Access	Read / Write	
Unit	-	
Values	Continuous	Gain is constantly adjusted by the device.
	Off	Gain is User controlled using Gain.
	Once	Gain is automatically adjusted once by the device. Once it has converged, it automatically returns to the Off state.

7.3.6 GainSelector

Selects which gain is controlled by the various gain features.

Name	GainSelector	
Category	AnalogControl	
Interface	IEnumeration	
Access	Read / Write	
Unit	-	
Values	All	Gain will be applied to all channels or taps.
	Blue	Gain will be applied to the blue channel. (color cameras only)
	GreenBlue	Gain will be applied to the green blue channel. (color cameras only)
	GreenRed	Gain will be applied to the green red channel. (color cameras only)
	Red	Gain will be applied to the red channel. (color cameras only)

7.3.7 Gamma

Controls the gamma correction of pixel intensity. This is typically used to compensate for non-linearity of the display system (such as CRT).

Name	Gamma
Category	AnalogControl
Interface	IFloat
Access	Read / Write
Unit	-
Values	0.1 - 2.0 (Increment: 0.10)

7.3.8 HighConversionGainEnable

Enables the high conversion gain mode inside the sensor.

This function makes the image brighter. However, the quality of the image is better than when the exposure time alone is increased. Combine both functions.

Notice

The camera must be stopped before this feature can be edited.

The following cameras support this function:

Camera Type	HighConversionGainEnable
Mono	
VLXT-06M.I	■
VLXT-17M.I	■
VLXT-28M.I	■
VLXT-71M.I	■
Color	
VLXT-71C.I	■

Name	HighConversionGainEnable
Category	AnalogControl
Interface	IBoolean
Access	Read / Write
Unit	-
Values	true = 1 (On) false = 0 (Off)

7.3.9 HighConversionGain

Returns the high conversion gain of the sensor.

Name	HighConversionGain
Category	AnalogControl
Interface	IFloat
Access	Read only
Unit	-
Values	1.0 - dependent on sensor (Increment: 1.00)

7.4 Category: AutoFeatureControl (≥ Release 2 only)

Category that contains the auto feature control features.

General Information

Various auto features are available to affect the automatic adjustment of image brightness. Two methods are described below.

BrightnessAutoPriority = ExposureAuto

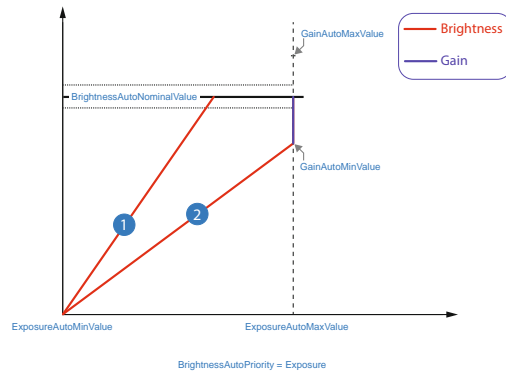

1 Example 1

For image 1, increasing the brightness with *ExposureTime* is sufficient to achieve the *BrightnessAutoNominalValue*.

2 Example 2

For image 2, increasing the brightness with *ExposureTime* is not enough to reach the value of *BrightnessAutoNominalValue*.

Therefore, the gain is increased after reaching *ExposureAutoMaxValue*.

BrightnessAutoPriority = GainAuto

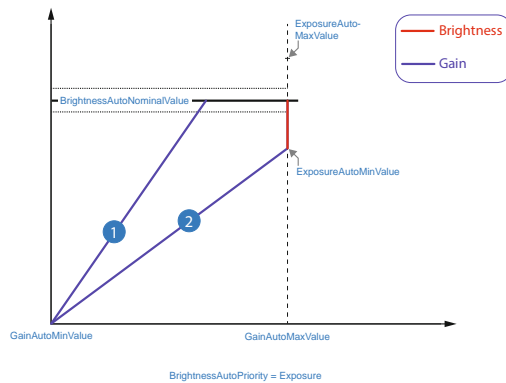

1 Example 1

For image 1, increasing the brightness with *Gain* is sufficient to achieve the *BrightnessAutoNominalValue*.

2 Example 2

For image 2, increasing the brightness with *Gain* is not enough to reach the value of *BrightnessAutoNominalValue*.

Therefore, the *ExposureTime* is increased after reaching *GainAutoMaxValue*.

AutoFeature ROI - General Information

You can use the AutoFeature Region of Interest (ROI) function to predefine a so-called region of interest. This ROI is an area of pixels on the sensor.

This function is used if only the image data (e.g. brightness) of a particular region of the image is of interest. The calculated corrections will be applied to the entire image.

The AutoFeature ROI is specified using four values:

- AutoFeatureOffsetX - x-coordinate of the first relevant pixel
- AutoFeatureOffsetY - y-coordinate of the first relevant pixel
- AutoFeatureWidth - horizontal size of the Region
- AutoFeatureHeight - vertical size of the Region

AutoFeature ROI in Full Frame

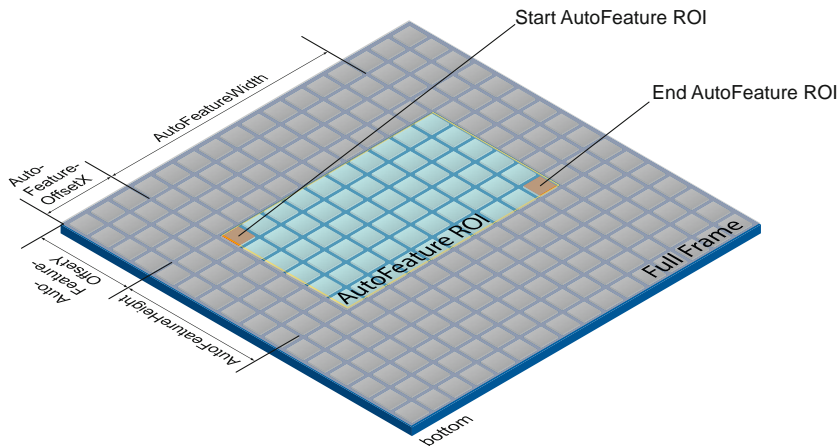

AutoFeature ROI in an ROI

Notice

It is possible to set an AutoFeature ROI in an ROI (Category: *ImageFormatControl*). The values that can be set for the AutoFeature ROI are adjusted accordingly.

The starting point for *AutoFeatureOffsetX* and *AutoFeatureOffsetY* is determined by the ROI (Category: *ImageFormatControl*).

It is not possible to use AutoFeature ROI and Multi ROI together.

If the AutoFeature ROI is outside the AutoFeatureRegionReference ROI (Category: *ImageFormatControl*) the corresponding AutoFeature cannot be started.

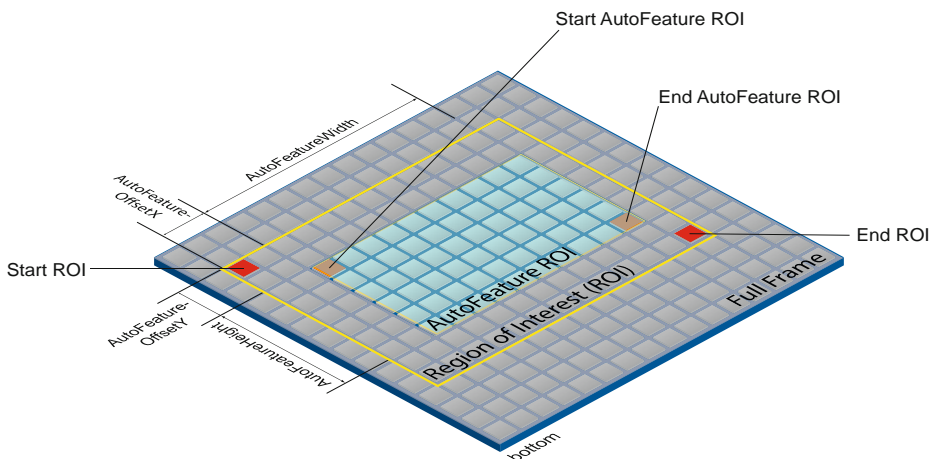

7.4.1 AutoFeatureHeight

Height of the selected Auto Feature Region (in pixels).

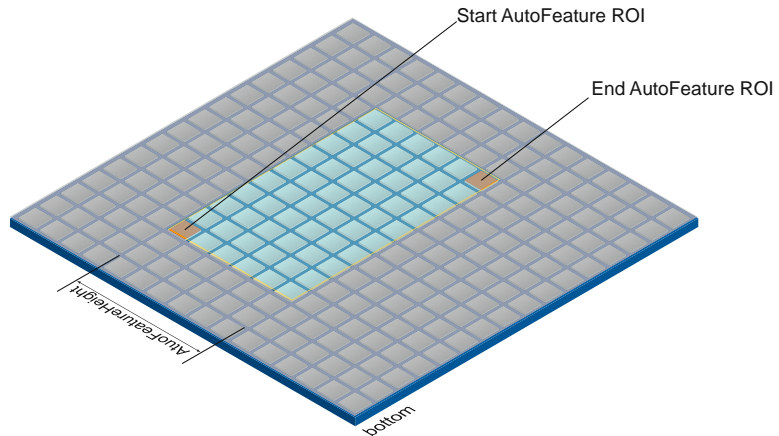

Name	AutoFeatureHeight
Category	AutoFeatureControl
Interface	Integer
Access	Read / Write
Unit	-
Values	see chapter „7.13.10 Height“ on page 143

7.4.2 AutoFeatureOffsetX

Horizontal offset from the origin to the Auto Feature Region (in pixels).

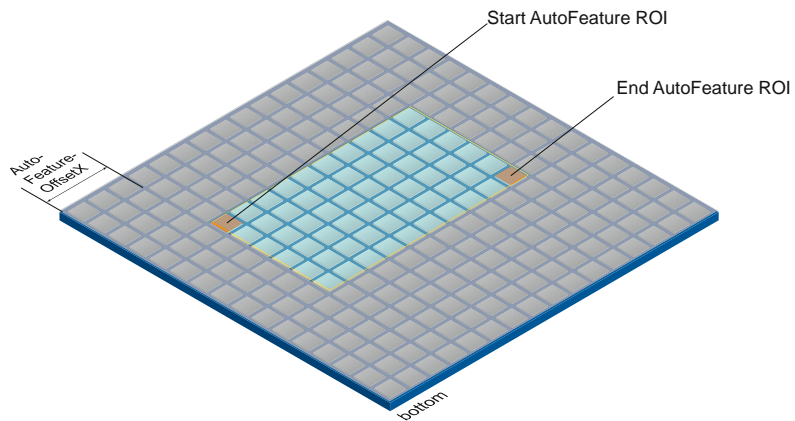

Name	AutoFeatureOffsetX
Category	AutoFeatureControl
Interface	Integer
Access	Read / Write
Unit	-
Values	0 - depends on set <i>AutoFeatureWidth</i>

7.4.3 AutoFeatureOffsetY

Vertical offset from the origin to the Auto Feature Region (in pixels).

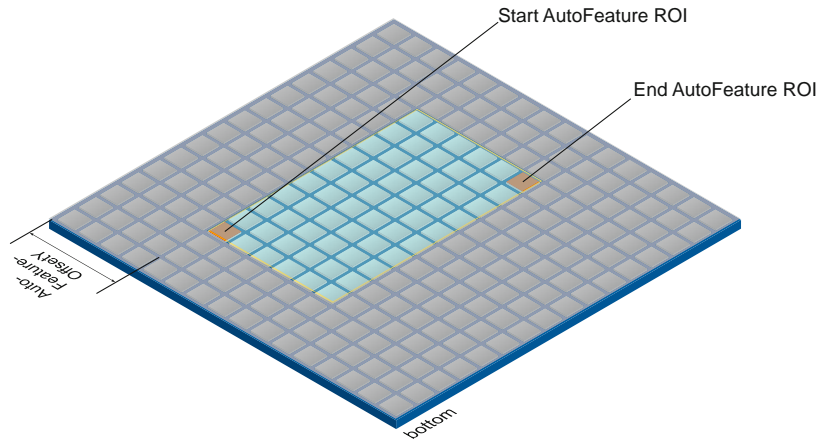

Name	AutoFeatureOffsetY
Category	AutoFeatureControl
Interface	Integer
Access	Read / Write
Unit	-
Values	0 - depends on set <i>AutoFeatureHeight</i>

7.4.4 AutoFeatureRegionMode

Controls the mode of the selected Auto Feature Region (AutoFeature ROI).

Notice

The camera must be stopped before this feature can be edited.

Name	AutoFeatureRegionMode	
Category	AutoFeatureControl	
Interface	Enumeration	
Access	Read / Write	
Unit	-	
Values	Off	All settings of the selected AutoFeature ROI are automatically equal to the selected AutoFeatureRegionReference.
	On	The settings of the selected AutoFeature ROI are user defined. The AutoFeature is useable only if the AutoFeature ROI fits into the AutoFeatureregionReference of the AutoFeature.

7.4.5 AutoFeatureRegionReference

The Reference Region of interest. The Auto Feature Region is part of this region and all Auto Feature Region features are refer to this Reference Region.

Name	AutoFeatureRegionReference
Category	AutoFeatureControl
Interface	IEnumeration
Access	Read / Write
Unit	-
Values	Region0 The selected Auto Feature Region refers to Region 0.

7.4.6 AutoFeatureRegionSelector

Selects the Region of interest to control. The RegionSelector feature allows devices that are able to extract multiple regions out of an image, to configure the features of those individual regions independently.

Name	AutoFeatureRegionSelector
Category	AutoFeatureControl
Interface	IEnumeration
Access	Read / Write
Unit	-
Values	BalanceWhite-Auto Selected features will control the region for Balance-WhiteAuto and ColorTransformationAuto algorithm.
	Brightness-Auto Selected features will control the region for GainAuto and ExposureAuto algorithm.

7.4.7 AutoFeatureWidth

Width of the selected Auto Feature Region (in pixels).

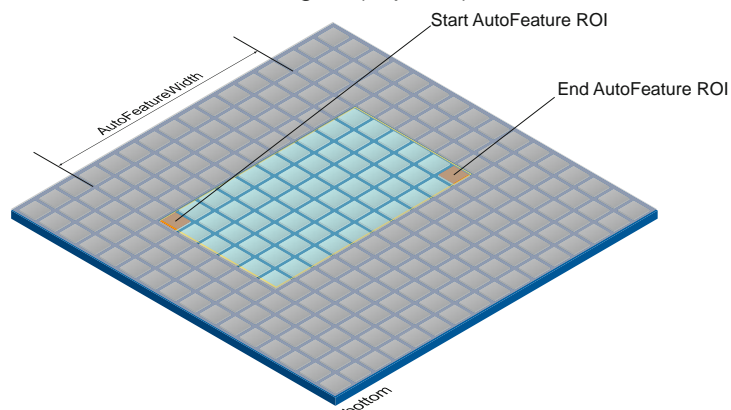

Name	AutoFeatureWidth
Category	AutoFeatureControl
Interface	IInteger
Access	Read / Write
Unit	-
Values	see chapter „7.13.32 Width“ on page 158

7.4.8 BalanceWhiteAutoStatus

Status of BalanceWhiteAuto.

Name	BalanceWhiteAutoStatus	
Category	AutoFeatureControl	
Interface	IEnumeration	
Access	Read / Write	
Unit	-	
Values	ColorGain- sTooHigh	The BalanceWhiteAuto calculation failed since at least one of the calculated color gains exceeds the maximum value.
	Initial	BalanceWhiteAuto has never been started.
	Start	BalanceWhiteAuto is waiting for statistic data.
	Success	The last BalanceWhiteAuto calculation succeeded.
	Underrun	The BalanceWhiteAuto calculation failed since at least one color-channel shows invalid statistic data.

7.4.9 BrightnessAutoNominalValue

Sets the nominal value for brightness in percent of full scale. It will be adjusted with consider the setting in BrightnessAutoPriority.

Name	BrightnessAutoNominalValue	
Category	AutoFeatureControl	
Interface	IFloat	
Access	Read / Write	
Unit	%	
Values	5 - 95 (Increment: 1)	

7.4.10 BrightnessAutoPriority

The feature set the highest priority auto feature to adjust the brightness. If both, ExposureAuto and GainAuto, are enabled, this feature determines which one of the control-parameter ExposureTime or Gain shall be adjusted first. If the prioritized parameter exceeds the minimum or maximum limit the second parameter will be adjusted to reach the target brightness.

Notice

If BrightnessAutoPriority is set to ExposureAuto the image frame rate might be reduced due to an increased ExposureTime but the image noise will not change..

If BrightnessAutoPriority is set to GainAuto there might occur image noise due to an increased Gain but the image frame rate remains constant.

Name	BrightnessAutoPriority	
Category	AutoFeatureControl	
Interface	IEnumeration	
Access	Read / Write	
Unit	-	
Values	ExposureAuto	ExposureAuto has highest priority and will be modified first.
	GainAuto	GainAuto has highest priority and will be modified first.

BrightnessAutoPriority = ExposureAuto

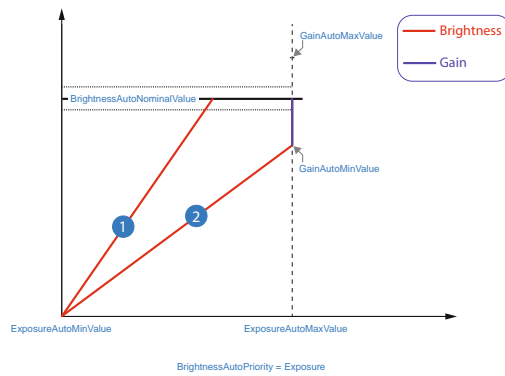

1 Example 1

For image 1, increasing the brightness with *ExposureTime* is sufficient to achieve the *BrightnessAutoNominalValue*.

2 Example 2

For image 2, increasing the brightness with *ExposureTime* is not enough to reach the value of *BrightnessAutoNominalValue*.

Therefore, the gain is increased after reaching *ExposureAutoMaxValue*.

BrightnessAutoPriority = GainAuto

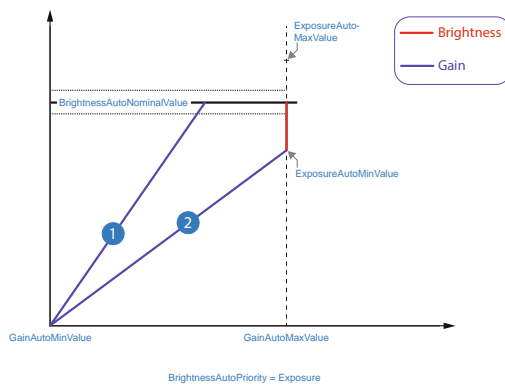

1 Example 1

For image 1, increasing the brightness with *Gain* is sufficient to achieve the *BrightnessAutoNominalValue*.

2 Example 2

For image 2, increasing the brightness with *Gain* is not enough to reach the value of *BrightnessAutoNominalValue*.

Therefore, the *ExposureTime* is increased after reaching *ExposureAutoMaxValue*.

7.4.11 ExposureAutoMaxValue

Maximal value of *ExposureTime* calculable by exposure auto algorithm.

Name	ExposureAutoMaxValue
Category	AutoFeatureControl
Interface	IFloat
Access	Read / Write
Unit	µs
Values	Adjustable value depends on the camera. see chapter „7.1.12 ExposureTime“ on page 60

7.4.12 ExposureAutoMinValue

Minimal value of ExposureTime calculable by exposure auto algorithm.

Name	ExposureAutoMinValue
Category	AutoFeatureControl
Interface	IFloat
Access	Read / Write
Unit	µs
Values	Adjustable value depends on the camera. see chapter „7.1.12 ExposureTime“ on page 60

7.4.13 GainAutoMaxValue

Maximum value of Gain calculable by gain auto algorithm.

Name	GainAutoMaxValue
Category	AutoFeatureControl
Interface	IFloat
Access	Read / Write
Unit	µs
Values	Adjustable value depends on the camera. see chapter „7.3.4 Gain“ on page 69

7.4.14 GainAutoMinValue

Minimal value of Gain calculable by gain auto algorithm.

Name	GainAutoMinValue
Category	AutoFeatureControl
Interface	IFloat
Access	Read / Write
Unit	µs
Values	Adjustable value depends on the camera. see chapter „7.3.4 Gain“ on page 69

7.5 Category: ChunkDataControl

The chunk is a data packet that is generated by the camera and integrated into the payload (every image), if chunk mode is activated. This data include different settings for the respective image. This integrated data packet contains different image settings. Baumer GAPI can read the Image Info Header (Chunk).

There are three Chunk modes:

Image Data

Only the image data is transferred, no Chunk data.

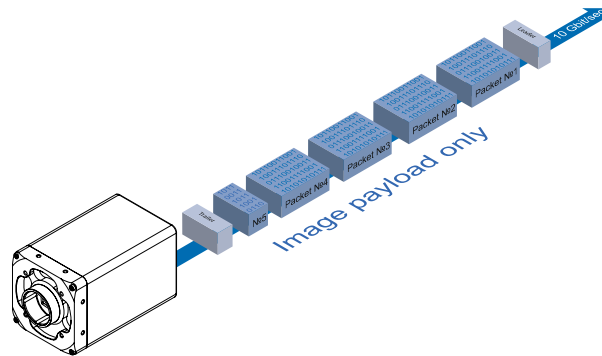

Chunk Data

Only the chunk is transferred, no image data.

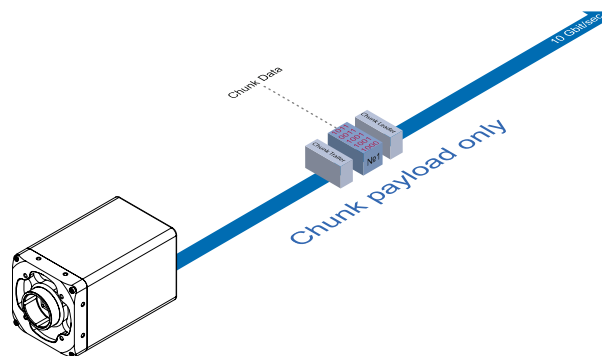

Extended Chunk Data

Chunk data and image data is transferred. The Chunk Data are included in the last data packet.

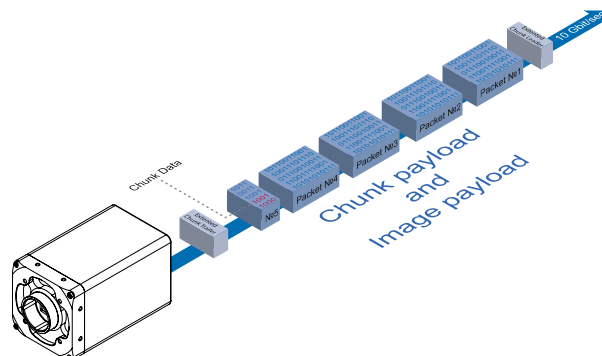

7.5.1 ChunkEnable

Enables the inclusion of the selected chunk data in the payload of the image.

Notice

You can choose the desired chunk under *Chunk Selector*.

Notice

The camera must be stopped before this feature can be edited.

Name	ChunkEnable
Category	ChunkDataControl
Interface	IBoolean
Access	Read / Write
Unit	-
Values	true = 1 (On) false = 0 (Off)

7.5.2 ChunkModeActive

Activates the inclusion of chunk data in the payload of the image.

Notice

The camera must be stopped before feature can be edited.

Name	ChunkModeActive
Category	ChunkDataControl
Interface	IBoolean
Access	Read / Write
Unit	-
Values	true = 1 (On) false = 0 (Off)

7.5.3 ChunkSelector

Selects which chunk to enable or control.

Name	ChunkSelector
Category	ChunkDataControl
Interface	IEnumeration
Access	Read / Write
Unit	-
Values	see table below

Feature	Description
Binning (subordinate features only together selectable)	
BinningHorizontal	Number of horizontal photo-sensitive cells to combine together.
BinningHorizontalMode	Sets the mode to use to combine horizontal photo-sensitive cells together when BinningHorizontal is used.
BinningSelector	Selects which binning engine is controlled by the BinningHorizontal and BinningVertical features.
BinningVertical	Number of vertical photo-sensitive cells to combine together.
BinningVerticalMode	Sets the mode used to combine horizontal photo-sensitive cells together when BinningVertical is used.
BlackLevel	Returns the black level used to capture the image included in the payload.
CounterValue (≥ Rel. 2 only)	Returns the current value of the selected Counter.
DeviceTemperature	Device temperature in degrees Celsius (C). It is measured at the location selected by DeviceTemperatureSelector.
ExposureTime	Returns the exposure time used to capture the image.
FrameID	Returns the unique Identifier of the frame (or image) included in the payload.
Gain	Returns the gain used to capture the image.
Height	Returns the height of the image included in the payload.
Image	Transmits the Image data in chunk block.
ImageControl (subordinate features only together selectable)	
DefectPixelCorrection	On/Off the correction of defect pixels.
FixedPatternNoise	On/ Off the Fixed pattern noise correction.
ReverseX	On/Off Flip horizontally the image sent by the device. The Region of interest is applied after the flipping.
ReverseY	On/Off Flip vertically the image sent by the device. The Region of interest is applied after the flipping.
LineStyleAll	Returns the current status of all available Line signals at time of polling in a single bitfield.
OffsetX	Horizontal offset from the origin to the area of interest (in pixels).
OffsetY	Vertical offset from the origin to the area of interest (in pixels).
PixelFormat	Returns the pixel format of the image included in the payload.
SequencerSetActive	Returns the active sequencer set.
Timestamp	Returns the Timestamp of the image included in the payload at the time of the FrameStart internal event.
TriggerID (Rel. 2 only)	Returns the Trigger ID and the Trigger Source. The Trigger ID counts the incoming triggers of the signal selected at <i>TriggerSource</i> . When the signal <i>Action1</i> is selected, the Request ID and the Source IP of the triggering device are output.
TriggerControl (≥ Rel. 3) (subordinate features only together selectable)	Returns ActionRequestID, ActionSourceIP, Timestamp, TriggerCounter and TriggerSource.
Width	Returns the width of the image included in the payload.

7.6 Category: ColorTransformationControl (color cameras only)

Category that contains the Color Transformation control features.

Oversimplified, color processing is realized by 4 modules.

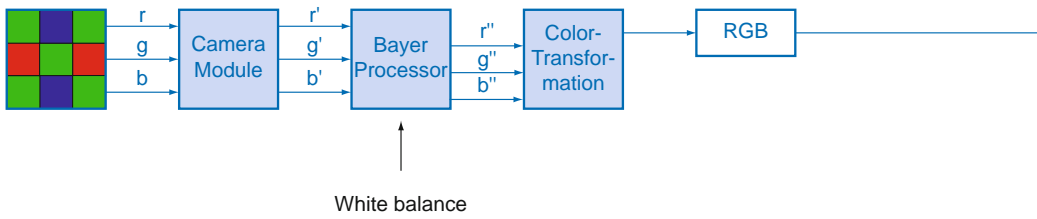

Figure 16: Color processing modules of color cameras.

The color signals r (red), g (green) and b (blue) of the sensor are amplified in total and digitized within the camera module.

Within the Bayer processor, the raw signals r' , g' and b' are amplified by using of independent factors for each color channel. Then the missing color values are interpolated, which results in new color values (r'' , g'' , b'').

The next step is the color transformation. Here the previously generated color signals r'' , g'' and b'' are converted to optimized RGB (Color adjustment as physical balance of the spectral sensitivities).

7.6.1 ColorTransformationAuto

Controls the mode for automatic adjusting the gains of the active transformation matrix.

Name	ColorTransformationAuto	
Category	ColorTransformationControl	
Interface	IEnumeration	
Access	Read / Write	
Unit	-	
Values	Continuous	Color transformation is constantly adjusted by the device.
	Off	Color transformation is user controlled using the various Colortransformation features
	Once	Color transformation is automatically adjusted once by the device. Once it has converged, it automatically returns to the Off state.

7.6.2 ColorTransformationEnable

Activates the selected Color Transformation module.

Name	ColorTransformationEnable	
Category	ColorTransformationControl	
Interface	IBoolean	
Access	Read only	
Unit	-	
Values	true = 1 (On)	
	false = 0 (Off)	

7.6.3 ColorTransformationFactoryListSelector

Selects the OptimizedMatrix for the desired color temperature.

Name	ColorTransformationFactoryListSelector	
Category	ColorTransformationControl	
Interface	IEnumeration	
Access	Read / Write	
Unit	-	
Values	OptimizedMatrix-For3000K	Matrix is tuned to the color temperature of 3000K.
	OptimizedMatrix-For5000K (≥ Rel. 2 only)	Matrix is tuned to the color temperature of 5000K.
	OptimizedMatrix-For6500K	Matrix is tuned to the color temperature of 6500K.
	OptimizedMatrix-For9500K (≥ Rel. 2 only)	Matrix is tuned to the color temperature of 9500K.

7.6.4 ColorTransformationOutputColorSpace (≥ Release 2 only)

Returns the color space of the camera.

Name	ColorTransformationOutputColorSpace
Category	ColorTransformationControl
Interface	IString
Access	Read only
Unit	-
Values	Color space (sRGB Gamma 1)

7.6.5 ColorTransformationResetToFactoryList

Resets the ColorTransformation to the selected ColorTransformationFactoryList.

Name	ColorTransformationResetToFactoryList
Category	ColorTransformationControl
Interface	ICommand
Access	Write only
Unit	-
Values	-

7.6.6 ColorTransformationValue

Represents the value of the selected Gain factor inside the Transformation matrix.

Name	ColorTransformationValue
Category	ColorTransformationControl
Interface	IFloat
Access	Read / Write
Unit	-
Values	-8.0 – 8.0 (Increment: 1.00)

7.6.7 ColorTransformationValueSelector

Selects the Gain factor of the Transformation matrix to access in the selected Color Transformation module.

Name	ColorTransformationValueSelector
Category	ColorTransformationControl
Interface	IEnumeration
Access	Read / Write
Unit	-
Values	<ul style="list-style-type: none">▪ Gain00▪ Gain01▪ Gain02▪ Gain10▪ Gain11▪ Gain12▪ Gain20▪ Gain21▪ Gain22

7.7 Category: CounterAndTimerControl

This chapter lists all features that relates to control and monitoring of Counters and Timers.

7.7.1 CounterDuration

Sets the duration (or number of events) before the CounterEnd event is generated.

When the counter reaches the CounterDuration value, a CounterEnd event is generated, the CounterActive signal becomes inactive and the counter stops counting until a new trigger happens or it is explicitly reset with CounterReset.

Name	CounterDuration
Category	CounterAndTimerControl
Interface	Integer
Access	Read / Write
Unit	-
Values	0 ... 65535 (Increment: 1)

7.7.2 CounterEventActivation

Selects the Activation mode Event Source signal.

Name	CounterEventActivation	
Category	CounterAndTimerControl	
Interface	IEumeration	
Access	Read / Write	
Unit	-	
Values	RisingEdge	Counts on the Rising Edge of the signal.
	FallingEdge	Counts on the Falling Edge of the signal.
	AnyEdge	Counts on the Falling or rising Edge of the selected signal.

7.7.3 CounterEventSource

Selects the signals that will be the source to increment the Counter.

Name	CounterEventSource	
Category	CounterAndTimerControl	
Interface	IEumeration	
Access	Read / Write	
Unit	-	
Values	Counter1End	Counts the number of Counter End.
	Counter2End	Counts the number of Counter End.
	ExposureActive	Counts all Exposures.
	FrameTransferSkipped	Counts when a frame transfer skipped.
	FrameTrigger	Counts the number of Frame Start Trigger.
	Line0 (≥ Rel. 2 only)	Counts by the chosen I/O Line.
	Line1 (≥ Rel. 2 only)	Counts by the chosen I/O Line.
	Off	Disable the Counter Reset trigger.
	TriggerSkipped	Counts when a Trigger skipped.

7.7.4 CounterReset

Does a software reset of the selected Counter and starts it. The counter starts counting events immediately after the reset unless a Counter trigger is active. CounterReset can be used to reset the Counter independently from the CounterResetSource. To disable the counter temporarily, set CounterEventSource to Off.

Notice

Note that the value of the Counter at time of reset is automatically latched and reflected in the *CounterValueAtReset*.

Name	CounterReset	
Category	CounterAndTimerControl	
Interface	ICommand	
Access	Write only	
Unit	-	
Values	-	

7.7.5 CounterResetActivation

Selects the Activation mode of the Counter Reset Source signal.

Name	CounterResetActivation	
Category	CounterAndTimerControl	
Interface	IEumeration	
Access	Read / Write	
Unit	-	
Values	RisingEdge	Resets the counter on the Rising Edge of the signal.
	FallingEdge	Resets the counter on the Falling Edge of the signal.
	AnyEdge	Resets the counter on the Falling or rising Edge of the selected signal.

7.7.6 CounterResetSource

Selects the signals that will be the source to reset the Counter.

Name	CounterResetSource	
Category	CounterAndTimerControl	
Interface	IEumeration	
Access	Read / Write	
Unit	-	
Values	Counter1End	Resets with the reception of the Counter End.
	Counter2End	Resets with the reception of the Counter End.
	Line0 (≥ Rel. 2 only)	Resets by the chosen I/O Line.
	Line1 (≥ Rel. 2 only)	Resets by the chosen I/O Line.
	Off	Disable the Counter Reset trigger.

7.7.7 CounterSelector

Selects which Counter to configure.

Name	CounterSelector	
Category	CounterAndTimerControl	
Interface	IEumeration	
Access	Read / Write	
Unit	-	
Values	Counter1	Selects the counter 1.
	Counter2	Selects the counter 2.

7.7.8 CounterValue

Reads or writes the current value of the selected Counter. Writing to CounterValue is typically used to set the start value.

Name	CounterValue
Category	CounterAndTimerControl
Interface	Integer
Access	Read / Write
Unit	-
Values	0 ... 65535 (Increment: 1)

7.7.9 CounterValueAtReset

Reads the value of the selected Counter when it was reset by a trigger or by an explicit CounterReset command.

It represents the last counter value latched before resetting the counter.

Name	CounterValueAtReset
Category	CounterAndTimerControl
Interface	Integer
Access	Read only
Unit	-
Values	0 ... 65535 (Increment: 1)

7.7.10 FrameCounter

The FrameCounter is part of the Baumer Image Info Header (chunk) and is added to every image if chunk mode is activated. It is generated by the hardware and can be used to verify that each of the camera's images is transmitted to the PC and received in the right order.

It is possible to set the FrameCounter to a specific value by write this value to the FrameCounter.

Name	FrameCounter
Category	CounterAndTimerControl
Interface	Integer
Access	Read / Write
Unit	-
Values	0 ... 4294967295 (Increment: 1)

7.7.11 TimerDelay

Sets the duration (in microseconds) of the delay to apply at the reception of a trigger before starting the Timer.

Name	TimerDelay
Category	CounterAndTimer
Interface	IFloat
Access	Read / Write
Unit	µs
Values	0 ... 2,000,000.000000 (Increment: 1.00)

7.7.12 TimerDuration

Sets the duration (in microseconds) of the Timer pulse.

Name	TimerDuration
Category	CounterAndTimer
Interface	IFloat
Access	Read / Write
Unit	µs
Values	10.000000 ... 2,000,000.000000 (Increment: 1.00)

7.7.13 TimerSelector

Selects which Timer to configure.

Name	TimerSelector
Category	CounterAndTimerControl
Interface	IEumeration
Access	Read / Write
Unit	-
Values	Timer1 Selects the Timer 1.

7.7.14 TimerTriggerActivation

Selects the activation mode of the trigger to start the Timer.

Name	TimerTriggerActivation	
Category	CounterAndTimerControl	
Interface	IEumeration	
Access	Read / Write	
Unit	-	
Values	RisingEdge	Starts counting on the Rising Edge of the selected trigger signal.
	FallingEdge	Starts counting on the Falling Edge of the selected trigger signal.
	AnyEdge	Starts counting on the Falling or Rising Edge of the selected trigger signal.

7.7.15 TimerTriggerSource

Selects the source of the trigger to start the Timer.

Name	TimerTriggerSource	
Category	CounterAndTimerControl	
Interface	IEumeration	
Access	Read / Write	
Unit	-	
Values	Action1	Starts with the assertion of the chosen action signal.
	ExposureEnd	Starts with the reception of the Exposure End.
	ExposureStart	Starts with the reception of the Exposure Start.
	FrameTransfer-Skipped	Frame Transfer Skipped.
	Line0	Starts when the specified TimerTriggerActivation condition is met on the chosen I/O Line.
	Line1	Starts when the specified TimerTriggerActivation condition is met on the chosen I/O Line.
	Off	Disables the Timer trigger.
	Software	Starts when the trigger was generated by the software.
	TriggerSkipped	Starts when a trigger was skipped.

7.8 Category: CustomDataControl (≥ Release 2 only)

The feature contains the category of the custom data related features.

7.8.1 CustomData

The feature holds one byte of custom special data.

Name	CustomData
Category	CustomDataControl
Interface	Integer
Access	Read / Write
Unit	-
Values	0x0 ... 0xFF (Increment: 1)

7.8.2 CustomDataConfigurationMode

Controls if the custom data configuration mode is active.

Name	CustomDataConfigurationMode
Category	CustomDataControl
Interface	Enumeration
Access	Read / Write
Unit	-
Values	Off Disables the custom data configuration mode. On Enables the custom data configuration mode.

7.8.3 CustomDataSelector

The feature selects the index of the custom data byte array.

Name	CustomDataSelector
Category	CustomDataControl
Interface	Integer
Access	Read / Write
Unit	-
Values	0 ... 127 (Increment: 1)

7.9 Category: DeviceControl

Category for device information and control.

7.9.1 DeviceCharacterSet

Character set used by the strings of the device's bootstrap registers.

Name	DeviceCharacterSet
Category	DeviceControl
Interface	IEnumeration
Access	Read only
Unit	-
Values	UTF8 Device uses UTF8 character set.

7.9.2 DeviceEventChannelCount

Indicates the number of event channels supported by the device.

Name	DeviceEventChannelCount
Category	DeviceControl
Interface	IInteger
Access	Read only
Unit	-
Values	0 ... 4294967295 (Increment: 1)

7.9.3 DeviceFamilyName

Identifier of the product family of the device.

Name	DeviceFamilyName
Category	DeviceControl
Interface	IString
Access	Read only
Unit	-
Values	device family name (e.g. VLXT)

7.9.4 DeviceFirmwareVersion

Version of the firmware in the device.

Name	DeviceFirmwareVersion
Category	DeviceControl
Interface	IString
Access	Read only
Unit	-
Values	e.g. CID:012004/PID:11208326

7.9.5 DeviceLinkCommandTimeout

Indicates the current command timeout of the specific Link.

Name	DeviceLinkCommandTimeout
Category	DeviceControl
Interface	IFloat
Access	Read only
Unit	µs
Values	200,000.000000 (Increment: 1)

7.9.6 DeviceLinkHeartbeatMode

Activate or deactivate the Link's heartbeat.

Name	DeviceLinkHeartbeatMode
Category	DeviceControl
Interface	IEnumeration
Access	Read / Write
Unit	-
Values	On Enables the Link heartbeat. Off Disables the Link heartbeat.

7.9.7 DeviceLinkHeartbeatTimeout

Controls the current heartbeat timeout of the specific Link.

Name	DeviceLinkHeartbeatTimeout
Category	DeviceControl
Interface	IFloat
Access	Read / Write
Unit	µs
Values	500,000.000000 ... 4,294,967,295,000.000000 (Increment: 1)

7.9.8 DeviceLinkSelector

Selects which Link of the device to control.

Generally, a device has only one Link that can be composed of one or many connections. But if there are many, this selector can be used to target a particular Link of the device with certain features.

Name	DeviceLinkSelector
Category	DeviceControl
Interface	Integer
Access	Read / Write
Unit	-
Values	0 ... 0 (Increment: 1)

7.9.9 DeviceLinkSpeed

Indicates the speed of transmission negotiated on the specified link.

Name	DeviceLinkSpeed
Category	DeviceControl
Interface	Integer
Access	Read only
Unit	Bps
Values	0 ... 9223372036854775807 (Increment: 1)

7.9.10 DeviceLinkThroughputLimit

Limits the maximum bandwidth of the data that will be streamed out by the device on the selected Link. If necessary, delays will be uniformly inserted between transport layer packets in order to control the peak bandwidth.

Name	DeviceLinkThroughputLimit	
Category	DeviceControl	
Interface	Integer	
Access	Read / Write	
Unit	Bps	
Values	GigE	1250000 ... 125000000 (Increment: 12500000)
	5GigE	1250000 ... 625000000 (Increment: 12500000)
	10GigE	1250000 ... 1250000000 (Increment: 12500000)
	USB3	1000000 ... 400000000 (Increment: 1000000)

7.9.11 DeviceManufacturerInfo

Manufacturer information about the device.

The content might look as follows:

Firmware (F) / FPGA (C) / BL3-Version (BL)

Name	DeviceManufacturerInfo
Category	DeviceControl
Interface	IString
Access	Read only
Unit	-
Values	e. g. F:0200BBD4/C:0200BCFC/BL3.8:0200BAB4

7.9.12 DeviceModelName

Model of the device.

Name	DeviceModelName
Category	DeviceControl
Interface	IString
Access	Read only
Unit	-
Values	e.g. VLXT-90C.I

7.9.13 DeviceRegistersEndianness

Endianness of the register of the device.

Name	DeviceRegistersEndianness
Category	DeviceControl
Interface	IEnumeration
Access	Read only
Unit	-
Values	Big Device registers are big Endian.

7.9.14 DeviceReset

The Device Reset feature corresponds with the camera's switched on and switched off states. Using this means it is no longer necessary to disconnect the power supply.

Notice

The execution of this feature may take several seconds.

Name	DeviceReset
Category	DeviceControl
Interface	ICommand
Access	Write only
Unit	-
Values	-

7.9.15 DeviceResetToDeliveryState

By executing this feature, the camera is set to the factory settings. The settings stored in the camera (e.g. *UserSets*) will be lost.

Name	DeviceResetToDeliveryState
Category	DeviceControl
Interface	ICommand
Access	Write only
Unit	-
Values	-

7.9.16 DeviceSFNCVersionMajor

Major version of the Standard Features Naming Convention that was used to create the device's GenICam XML.

Name	DeviceSFNCVersionMajor
Category	DeviceControl
Interface	Integer
Access	Read only
Unit	-
Values	0 ... 9223372036854775807 (Increment: 1)

7.9.17 DeviceSFNCVersionMinor

Minor version of the Standard Features Naming Convention that was used to create the device's GenICam XML.

Name	DeviceSFNCVersionMinor
Category	DeviceControl
Interface	IInteger
Access	Read only
Unit	-
Values	0 ... 9223372036854775807 (Increment: 1)

7.9.18 DeviceSFNCVersionSubMinor

Sub minor version of the Standard Features Naming Convention that was used to create the device's GenICam XML.

Name	DeviceSFNCVersionSubMinor
Category	DeviceControl
Interface	IInteger
Access	Read only
Unit	-
Values	0 ... 9223372036854775807 (Increment: 1)

7.9.19 DeviceScanType

Scan type of the sensor of the device.

Name	DeviceScanType
Category	DeviceControl
Interface	IEnumeration
Access	Read only
Unit	-
Values	Areascan 2D Sensor.

7.9.20 DeviceSensorType

This feature specifies the type of the sensor.

Name	DeviceSensorType
Category	DeviceControl
Interface	IEnumeration
Access	Read only
Unit	-
Values	CMOS CMOS sensor.

7.9.21 DeviceSerialNumber

Device's serial number. This string is a unique identifier of the device.

Name	DeviceSerialNumber
Category	DeviceControl
Interface	IString
Access	Read only
Unit	-
Values	e.g. 1117281217

7.9.22 DeviceStreamChannelCount

Indicates the number of streaming channels supported by the device.

Name	DeviceStreamChannelCount
Category	DeviceControl
Interface	IInteger
Access	Read only
Unit	-
Values	0 ... 4294967295 (Increment: 1)

7.9.23 DeviceStreamChannelEndianness

Endianness of multi-byte pixel data for this stream.

Name	DeviceStreamChannelEndianness
Category	DeviceControl
Interface	IEnumeration
Access	Read / Write
Unit	-
Values	Little Endianness of multi-byte pixel data for this stream is little Endian.

7.9.24 DeviceStreamChannelPacketSize

Specifies the stream packet size, in bytes, to send on the selected channel for a Transmitter or specifies the maximum packet size supported by a receiver.

Name	DeviceStreamChannelPacketSize
Category	DeviceControl
Interface	IInteger
Access	Read only
Unit	Byte
Values	576 ... 9000 (Increment: 2)

7.9.25 DeviceStreamChannelSelector

Selects the stream channel to control.

Name	DeviceStreamChannelSelector
Category	DeviceControl
Interface	Integer
Access	Read / Write
Unit	-
Values	0 ... 0 (Increment: 1)

7.9.26 DeviceStreamChannelType

Reports the type of the stream channel.

Name	DeviceStreamChannelType
Category	DeviceControl
Interface	IEnumeration
Access	Read only
Unit	-
Values	Transmitter Data stream transmitter channel.

7.9.27 DeviceTLType

Transport Type of the device.

Name	DeviceTLType
Category	DeviceControl
Interface	IEnumeration
Access	Read only
Unit	-
Values	GigEVision

7.9.28 DeviceTLVersionMajor

Major version of the Transport Layer (GigE Vision® version) of the device.

Name	DeviceTLVersionMajor
Category	DeviceControl
Interface	Integer
Access	Read only
Unit	-
Values	0 ... 65535 (Increment: 1)

7.9.29 DeviceTLVersionMinor

Minor version of the Transport Layer (GigE Vision® version) of the device.

Name	DeviceTLVersionMinor
Category	DeviceControl
Interface	Integer
Access	Read only
Unit	-
Values	0 ... 65535 (Increment: 1)

7.9.30 DeviceTLVersionSubMinor

Minor version of the Transport Layer (GigE Vision® version) of the device.

Name	DeviceTLVersionSubMinor
Category	DeviceControl
Interface	Integer
Access	Read only
Unit	-
Values	0 ... 9223372036854775807 (Increment: 1)

7.9.31 DeviceTemperature

Device temperature in degrees Celsius (C). It is measured at the location selected by *Device Temperature Selector*.

Name	DeviceTemperature
Category	DeviceControl
Interface	IFloat
Access	Read only
Unit	°C
Values	-127.0 ... 127.0

7.9.32 DeviceTemperatureExceeded

Returns if the device operates in critical temperature range.

Name	DeviceTemperatureExceeded
Category	DeviceControl
Interface	IBoolean
Access	Read only
Unit	-
Values	true = 1 (On) false = 0 (Off)

7.9.33 DeviceTemperatureSelector

Selects the location within the device, where the temperature will be measured.

Name	DeviceTemperatureSelector
Category	DeviceControl
Interface	IEnumeration
Access	Read / Write
Unit	-
Values	InHouse Temperature inside the camera housing.

7.9.34 DeviceTemperatureStatus

Returns the current temperature status of the device.

Name	DeviceTemperatureStatus
Category	DeviceControl
Interface	IEnumeration
Access	Read only
Unit	-
Values	Exceeded Device operates in critical temperature range. High Device operates in increased temperature range. Normal Device operates in normal temperature range.

7.9.35 DeviceTemperatureStatusTransition

Temperature threshold for selected status transition in degrees Celsius (C).

Name	DeviceTemperatureStatusTransition
Category	DeviceControl
Interface	IInteger
Access	Read / Write
Unit	°C
Values	-126.0 ... 71.0

7.9.36 DeviceTemperatureStatusTransitionSelector

Selects which temperature transition is controlled by the DeviceTemperatureStatusTransition feature.

Name	DeviceTemperatureStatusTransitionSelector	
Category	DeviceControl	
Interface	IEnumeration	
Access	Read / Write	
Unit	-	
Values	ExceededToNormal	Temperature threshold for transition from status Exceeded back to status Normal.
	HighToExceeded	Temperature threshold for transition from status High to status Exceeded.
	NormalToHigh	Temperature threshold for transition from status Normal to status High.

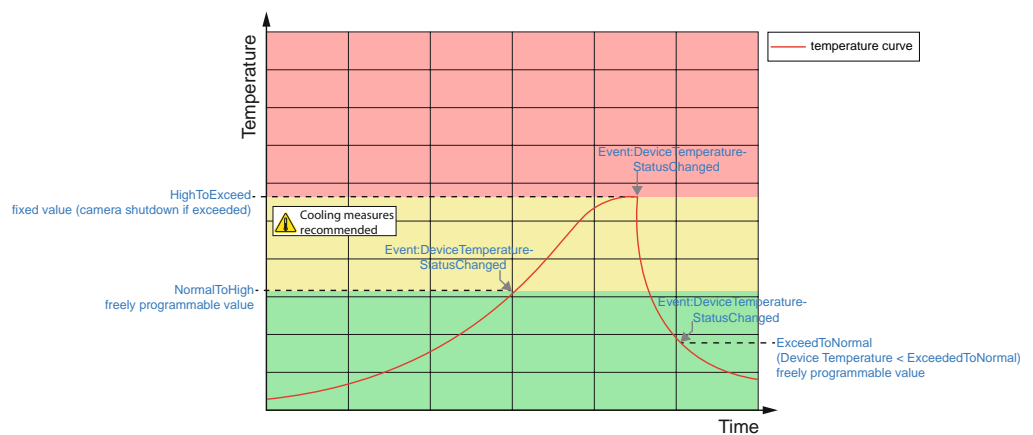

7.9.37 DeviceType

Returns the device type.

Name	DeviceType	
Category	DeviceControl	
Interface	IEnumeration	
Access	Read only	
Unit	-	
Values	Transmitter	Data stream transmitter device.

7.9.38 DeviceUserID

User-programmable device identifier.

Name	DeviceUserID	
Category	DeviceControl	
Interface	IString	
Access	Read / Write	
Unit	-	
Values	e.g. "camera 1" (max. length 64)	

7.9.39 DeviceVendorName

Name of the manufacturer of the device.

Name	DeviceVendorName
Category	DeviceControl
Interface	IString
Access	Read only
Unit	-
Values	Name of the camera manufacturer

7.9.40 DeviceVersion

Version of the device.

Name	DeviceVersion
Category	DeviceControl
Interface	IString
Access	Read only
Unit	-
Values	e.g. R1.0.0

7.9.41 ReadOutTime

Readout time in μs for current format settings.

Notice

Read Out Time depends on:

- OffsetY
- Height
- PixelFormat
- SensorBinning

Name	ReadOutTime
Category	DeviceControl
Interface	Integer
Access	Read only
Unit	μs
Values	0 ... 65535 (Increment: 1)

7.9.42 TimestampLatch

Latches the current timestamp counter into *TimestampLatchValue*.

Name	TimestampLatch
Category	DeviceControl
Interface	ICommand
Access	Write only
Unit	-
Values	-

7.9.43 TimestampLatchValue

Returns the latched value of the timestamp counter.

Name	TimestampLatchValue
Category	DeviceControl
Interface	IInteger
Access	Read only
Unit	ns
Values	0 ... 9223372036854775807 (Increment: 8)

7.9.44 TimestampLatchValuePtpDays (≥ Release 2 only)

The feature returns the latched value of the Ptp timestamp in days since 01.01.1970 00:00:00.

Name	TimestampLatchValuePtpDays
Category	DeviceControl
Interface	IInteger
Access	Read only
Unit	-
Values	0 ... 9223372036854775807 (Increment: 1)

7.9.45 TimestampLatchValuePtpHours (≥ Release 2 only)

The feature returns the latched value of the Ptp timestamp in hours since 00:00 AM.

Name	TimestampLatchValuePtpHours
Category	DeviceControl
Interface	IInteger
Access	Read only
Unit	-
Values	0 ... 23 (Increment: 1)

7.9.46 TimestampLatchValuePtpMinutes (≥ Release 2 only)

The feature returns the latched value of the Ptp timestamp in minutes since the last hour.

Name	TimestampLatchValuePtpMinutes
Category	DeviceControl
Interface	Integer
Access	Read only
Unit	-
Values	0 ... 59 (Increment: 1)

7.9.47 TimestampLatchValuePtpSeconds (≥ Release 2 only)

The feature returns the latched value of the Ptp timestamp counters in seconds since the last minute.

Name	TimestampLatchValuePtpSeconds
Category	DeviceControl
Interface	Integer
Access	Read only
Unit	s
Values	0 ... 59 (Increment: 1)

7.9.48 TimestampLatchValuePtpNanoseconds (≥ Release 2 only)

The feature returns the latched value of the Ptp timestamp in nanoseconds since the last second.

Name	TimestampLatchValuePtpNanoseconds
Category	DeviceControl
Interface	Integer
Access	Read only
Unit	ns
Values	0 ... 999999999 (Increment: 1)

7.9.49 TimestampReset

Resets the current value of the device timestamp counter.

Name	TimestampReset
Category	DeviceControl
Interface	ICommand
Access	Write only
Unit	-
Values	-

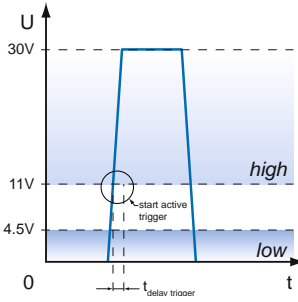

7.10 Category: DigitalIOControl

The Digital I/O chapter covers the features required to control the general Input and Output signals of the device.

Trigger (Line Selector → Line 0 / Line 1) (General Information)

Trigger signals are used to synchronize the camera exposure and a machine cycle or, in case of a software trigger, to take images at predefined time intervals.

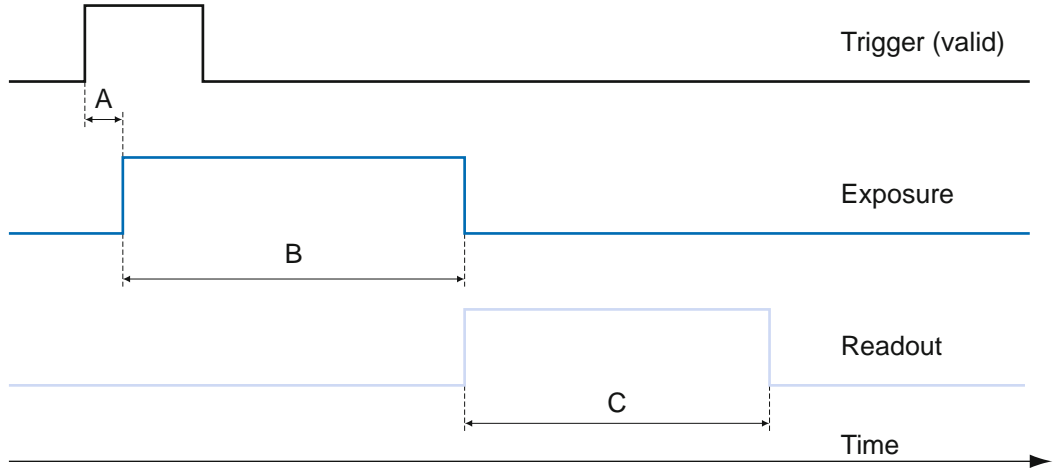

- A - Trigger delay
- B - Exposure time
- C - Readout time

Different trigger sources can be used here.

Trigger Delay:

The trigger delay is a flexible user-defined delay between the given trigger impulse and the image capture. The delay time can be set between 0.0 μ s and 2.0 s in increments of 1 μ s. Where there are multiple triggers during the delay, the triggers will also be stored and delayed. The buffer is able to store up to 512 trigger signals during the delay.

Your benefits:

- No need for an external trigger sensor to be perfectly aligned
- Different objects can be captured without hardware changes

Trigger Source (Examples of possible trigger sources)

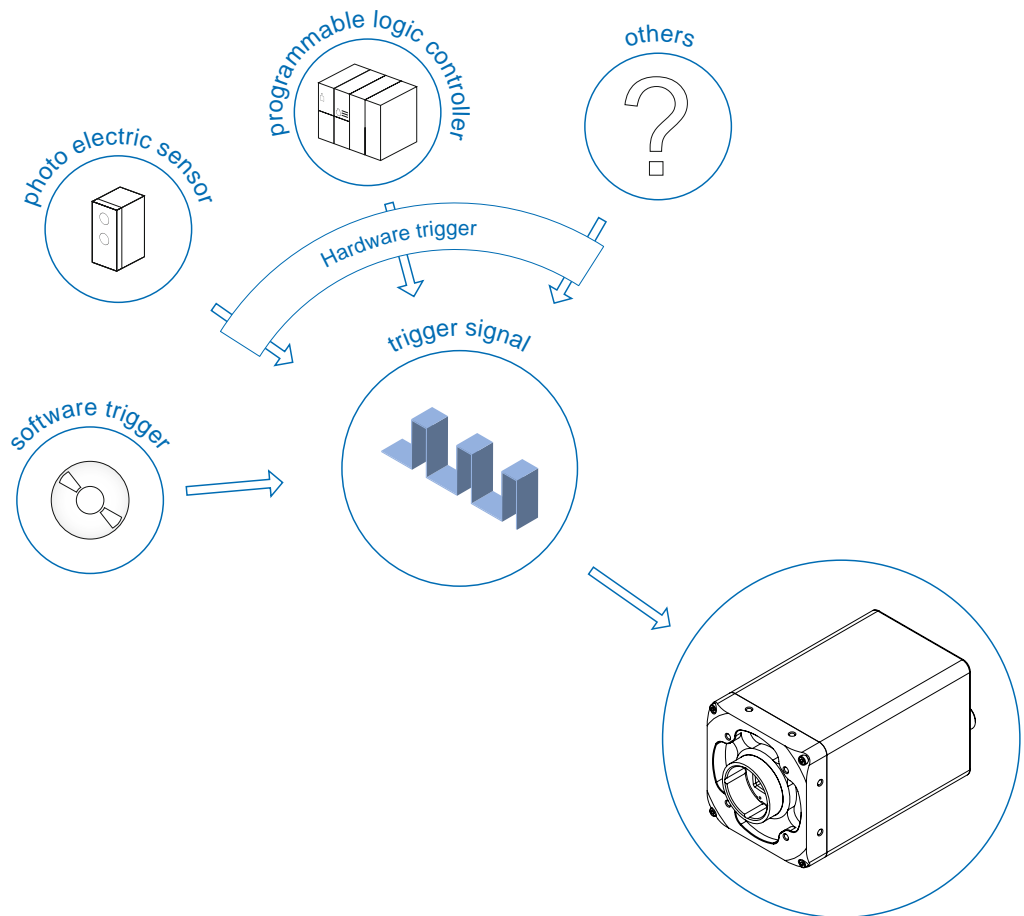

Each trigger source must be activated separately. When the trigger mode is activated, the hardware trigger is activated by default.

Debouncer (LineDebouncerHighTimeAbs / LineDebouncerLowTimeAbs)

The basic idea behind this features was to separate interfering signals (short peaks) from valid square wave signals, which can be important in industrial environments. Debouncing means that invalid signals are filtered out, and signals lasting longer than a user-defined testing time $t_{\text{DebounceHigh}}$ will be recognized and routed to the camera to induce a trigger.

In order to detect the end of a valid signal and filter out possible jitters within the signal, a second testing time $t_{\text{DebounceLow}}$ was introduced. The timing for this can also be adjusted by the user. If the signal value falls to state low and does not rise within $t_{\text{DebounceLow}}$, this is recognized as the end of the signal.

The debouncing times $t_{\text{DebounceHigh}}$ and $t_{\text{DebounceLow}}$ are adjustable from 0 to 5 ms in increments of 1 μs .

Notice

Please note that the edges of valid trigger signals are shifted by $t_{\text{DebounceHigh}}$ and $t_{\text{DebounceLow}}$.

Depending on these two timings, the trigger signal may be temporally stretched or compressed.

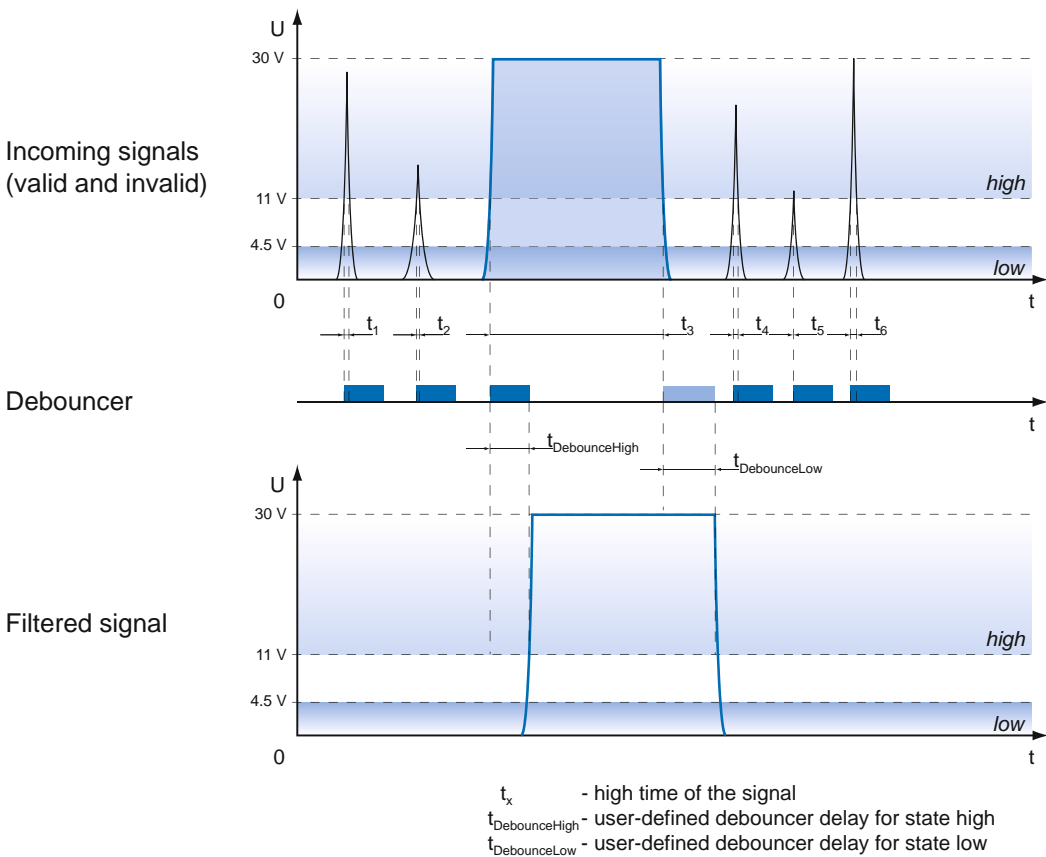

7.10.1 LineDebouncerHighTimeAbs

Sets the absolute value of the selected line debouncer time in microseconds for switch from low to high.

Name	LineDebouncerHighTimeAbs
Category	DigitalIOControl
Interface	IFloat
Access	Read / Write
Unit	µs
Values	0.000000 - 5,000.000000 (Increment: 1.00)

7.10.2 LineDebouncerLowTimeAbs

Sets the absolute value of the selected line debouncer time in microseconds for switch from high to low.

Name	LineDebouncerLowTimeAbs
Category	DigitalIOControl
Interface	IFloat
Access	Read / Write
Unit	µs
Values	0.000000 - 5,000.000000 (Increment: 1.00)

7.10.3 LineFormat

Controls the current electrical format of the selected physical input or output Line.

By switching the LineFormat, the behavior of the outputs can be adapted to the respective installation.

Notice

In all modes the supply voltage for the outputs (Pin 11, 12) must be connected!

Name	LineFormat
Category	DigitalIOControl
Interface	IEnumeration
Access	Read / Write
Unit	-
Values	see table below

The following line formats are available for each of the 4 outputs (Line 4, 5, 6, 7):

Modes	Description	Circuit
Push-Pull	<p>This mode is used to generate sharp edges for fast switching processes.</p> <p><u>Advantage:</u> Sharp edges in both directions.</p> <p><u>Disadvantage:</u> For long cable more susceptible to ground bounce and potential differences.</p>	
Open-Source	<p>Typical applications for this mode are: PLC input, control of illumination connected to ground.</p> <p><u>Advantage:</u> Stable at long cable lengths and potential differences.</p> <p><u>Disadvantage:</u> The falling edge has a lower slope due to parasitic capacitances. Switching off is slower due to this lower slope.</p>	
Open-Drain	<p>A typical case of application for this mode is a illumination control connected to plus.</p> <p><u>Advantage:</u> Stable at long cable lengths and potential differences.</p> <p><u>Disadvantage:</u> The rising edge has a lower slope due to parasitic capacitances. Switching off is slower due to this lower slope.</p>	

Tri-State In this mode, the output is disabled.

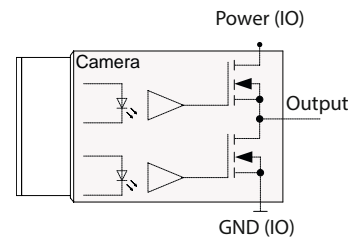

7.10.4 LineInverter

Controls the inversion of the signal of the selected input or output Line.

Name	LineInverter
Category	DigitalIOControl
Interface	IBoolean
Access	Read / Write
Unit	-
Values	true = 1 (On) false = 0 (Off)

7.10.5 LineMode

Controls if the physical Line is used to Input or Output a signal.

Name	LineMode				
Category	DigitalIOControl				
Interface	IEnumeration				
Access	Read only				
Unit	-				
Values	<table border="1"> <tr> <td>Input</td> <td>The selected physical line is used to Input an electrical signal.</td> </tr> <tr> <td>Output</td> <td>The selected physical line is used to Output an electrical signal.</td> </tr> </table>	Input	The selected physical line is used to Input an electrical signal.	Output	The selected physical line is used to Output an electrical signal.
Input	The selected physical line is used to Input an electrical signal.				
Output	The selected physical line is used to Output an electrical signal.				

7.10.6 LinePWMConfigurationMode

Activates the Features *LinePWMMaxDuration* and *LinePWMMaxDutyCycle*.

Name	LinePWMConfigurationMode	
Category	DigitalIOControl	
Interface	IEnumeration	
Access	Read / Write	
Unit	-	
Values	Off	Disables the line PWM configuration mode.
	On	Enables the line PWM configuration mode.

With the function *Pulse Width Modulated Outputs (PWM)* it is possible to control an illumination controller or an illumination directly connected to the camera in various ways. The set LineSource is used as a signal for the control.

⚠ Caution

Erroneous settings can destroy the illumination! The outputs of the camera are protected against destruction. Please follow the information in the data sheets for your illumination. Contact the manufacturer of the illumination if you are unsure about admissible parameters.

Setting a output to a specific illumination

1. Set *LinePWMConfigurationMode* to *true*
2.  Set at *LinePWMMaxDutyCycle* and *LinePWMMaxDuration* the maximum admissible parameters of your illumination (e.g. Falcon FLDR-i90B-IR24).

LinePWMMaxDutyCycle = 10 %
LinePWMMaxDuration = 10 ms
3. Set *LinePWMConfigurationMode* to *false*.

→ The values set in step 2 are now the max. admissible parameters.

Electrical specifications (Output Line4 ... Line7)

⚠ Danger!	
	Use in wet environments requiring IP67 protection
	Risk of electric shock. Electric shock can be fatal or cause serious injury.
	Use is only permitted under consideration of pollution degree 2 and overvoltage category 2.
	The M12 connectors must comply with the IEC 61076-2-101 standard.
	The dielectric strength and withstand voltage for the plug/socket combination must be checked according to DIN EN 60664-1:2008-01 for 60 V.

U_{EXT} : UL conform applications: 12 V (- 20 %) ... 24 V (+ 20 %)

U_{EXT} : not UL conform applications: 12 V (- 20 %) ... 48 V (+ 10 %)

I_{OUT} : - max. 1.5 A permanently in sum or per output individually

- Pulse 40 % of the period, max. 2.5 A (t_{ON} max 1 s)

- $t_{ON} = < 0.2 \mu s$ / $t_{OFF} = < 0.2 \mu s$

- max. Frequency: 500 kHz

Notice

In case of overload or short circuit, the outputs are disabled. To re-enable the output, disconnect Power (IO) (pin 12) from the power supply or perform a *DeviceReset*.

7.10.7 LinePWMDuration

Sets the pulse time in μs , with which the illumination is pulsed.

Name	LinePWMDuration
Category	DigitalIOControl
Interface	Integer
Access	Read / Write
Unit	μs
Values	1 - 5000 (Increment: 1)

7.10.8 LinePWMDutyCycle

Sets the duty cycle (ratio of pulse duration to period time duration) in %. This value is specified by the connected illumination.

Name	LinePWMDutyCycle
Category	DigitalIOControl
Interface	Integer
Access	Read / Write
Unit	%
Values	1 - 100 (Increment: 1)

7.10.9 LinePWMMaxDuration

Sets the maximum possible *LinePWMDuration* time in μs . This value is specified by the connected lighting. [Read/Write] (max = 50000 μs)

Name	LinePWMMaxDuration
Category	DigitalIOControl
Interface	Integer
Access	Read / Write
Unit	μs
Values	1 - 50000 (Increment: 1)

7.10.10 LinePWMMaxDutyCycle

Sets the maximum possible *LinePWMDutyCycle* in %. This value is specified by the connected illumination.

Name	LinePWMMaxDutyCycle
Category	DigitalIOControl
Interface	Integer
Access	Read / Write
Unit	%
Values	1 - 100 (Increment: 1)

7.10.11 LinePWMMode

Selects the PWM mode of the selected output line.

Name	LinePWMMode	
Category	DigitalIOControl	
Interface	IEnumeration	
Access	Read / Write	
Unit	-	
Values	Fixed Frequency	The selected output line generate a fixed frequency of pulses starting with every transition from 0 to 1 and stopping with every transition from 1 to 0.
	Off	The PWM Mode is off. The output line acts as a normal output.
	OnePulse	The selected output line generate one pulse with every transition from 0 to 1.

Timing diagrams of the PWMModes:

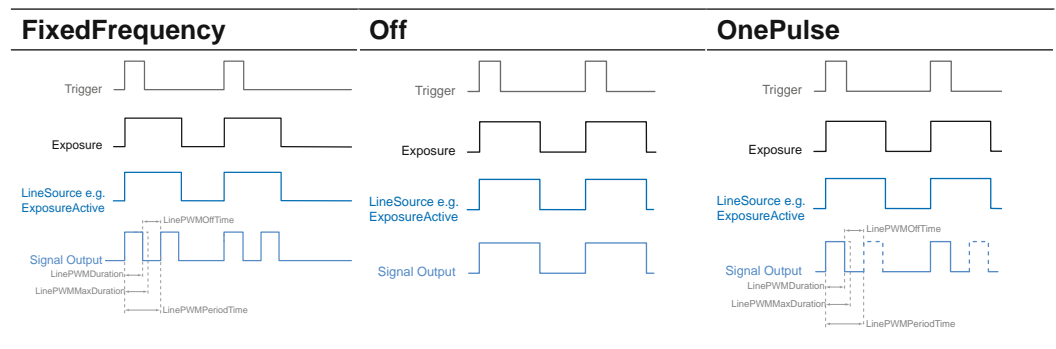

7.10.12 LinePWMOffTime

Offers the off time included in the PWM Period in microseconds.

Name	LinePWMMaxDutyCycle
Category	DigitalIOControl
Interface	Integer
Access	Read only
Unit	μs
Values	-9223372036854775808 - 9223372036854775808 (Increment: 1)

7.10.13 LinePWMPeriodTime

Readout of the entire period in μs .

Name	LinePWMPeriodTime
Category	DigitalIOControl
Interface	Integer
Access	Read only
Unit	μs
Values	depends on PWM settings

7.10.14 LineSelector

Selects the physical line (or pin) of the external device connector to configure.

Name	LineSelector	
Category	DigitalIOControl	
Interface	IEnumeration	
Access	Read / Write	
Unit	-	
Values	Line0	Index of the physical line and associated I/O control block to use.
	Line1	Index of the physical line and associated I/O control block to use.
	Line4	Index of the physical line and associated I/O control block to use.
	Line5	Index of the physical line and associated I/O control block to use.
	Line6	Index of the physical line and associated I/O control block to use.
	Line7	Index of the physical line and associated I/O control block to use.

7.10.15 LineSource

Input (Line Selector → Line 0 / Line 1)

The wiring of these input connector is left to the user.

Sole exception is the compliance with predetermined high and low levels (0 .. 4.5 V low, 11 .. 30 V high).

The defined signals will have no direct effect, but can be analyzed and processed on the software side and used for controlling the camera.

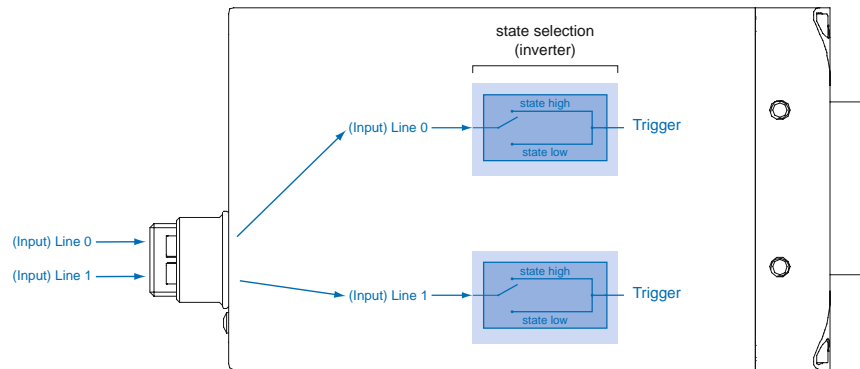

Output (Line Selector → Line 4 / Line 5 / Line 6 / Line 7)

Selects which internal acquisition or I/O source signal to output on the selected Line.

With this feature, Baumer gives you the option to wire the output connectors to internal signals that are controlled on the software side.

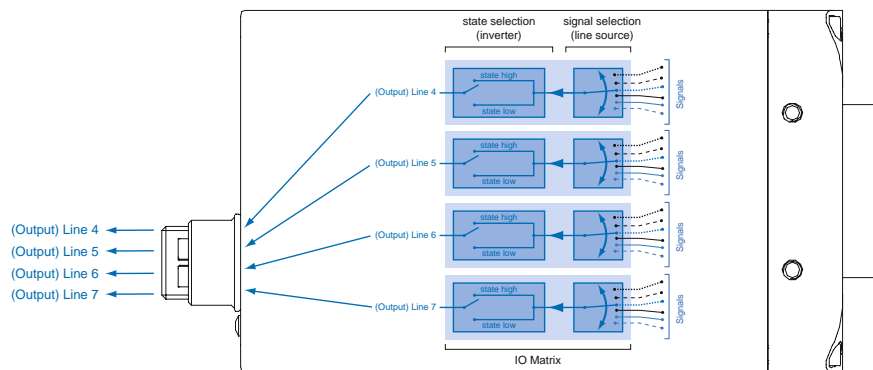

Name	LineSource
Category	DigitalIOControl
Interface	IEnumeration
Access	Read / Write
Unit	-
Values	see table below

Signals	
ExposureActive	Device is doing the exposure of a Frame (or Line).
Line 0	Device is currently waiting for signal of input line 0.
Line 1	Device is currently waiting for signal of input line 1.
Off	Line output is disabled (Tri-State).
ReadoutActive	Device is doing the readout of a Frame.
Timer1Active	The chosen Timer is in active state.
TriggerReady	Device is ready for trigger.
UserOutput1	The chosen User Output Bit state as defined by its current UserOutputValue.
UserOutput2	The chosen User Output Bit state as defined by its current UserOutputValue.
UserOutput3	The chosen User Output Bit state as defined by its current UserOutputValue.
UserOutput4	The chosen User Output Bit state as defined by its current UserOutputValue.

7.10.16 LineStatus

Returns the current status of the selected input or output Line.

Name	LineStatus
Category	DigitalIOControl
Interface	IBoolean
Access	Read only
Unit	-
Values	true = 1 (On) false = 0 (Off)

7.10.17 LineStatusAll

Returns the current status of all available Line signals at time of polling in a single bitfield.

Name	LineStatusAll
Category	DigitalIOControl
Interface	Integer
Access	Read only
Unit	-
Values	Devices-Specific (HexNumber)

7.10.18 UserOutputSelector

Selects which bit of the User Output register will be set by UserOutputValue.

Name	UserOutputSelector	
Category	DigitalIOControl	
Interface	IEnumeration	
Access	Read / Write	
Unit	-	
Values	UserOutput1	Selects the bit 0 of the User Output register.
	UserOutput2	Selects the bit 1 of the User Output register.
	UserOutput3	Selects the bit 2 of the User Output register.
	UserOutput4	Selects the bit 3 of the User Output register.

7.10.19 UserOutputValue

Sets the value of the bit selected by *UserOutputSelector*.

Name	UserOutputValue	
Category	DigitalIOControl	
Interface	IBoolean	
Access	Read / Write	
Unit	-	
Values	true = 1 (On)	
	false = 0 (Off)	

7.10.20 UserOutputValueAll

Sets the value of all the bits of the User Output register.

Name	UserOutputValueAll	
Category	DigitalIOControl	
Interface	IInteger	
Access	Read only	
Unit	-	
Values	0 ... 4294967295 (Increment: 1)	

7.11 Category: EventControl

This chapter describes how to control the generation of Events to the host application. An Event is a message that is sent to the host application to notify it of the occurrence of an internal event.

General Information

The asynchronous message channel is described in the GigE Vision® standard and offers the possibility of event signaling. There is a timestamp (64 bits) for each announced event, which contains the accurate time the event occurred.

Each event can be activated and deactivated separately (*EventSelector*).

7.11.1 EventNotification

Activate or deactivate the notification to the host application of the occurrence of the selected Event.

Name	EventNotification	
Category	EventControl	
Interface	IEnumeration	
Access	Read / Write	
Unit	-	
Values	Off	The selected Event notification is disabled.
	On	The selected Event notification is enabled.

7.11.2 EventSelector

Selects which Event to signal to the host application.

Name	EventSelector	
Category	EventControl	
Interface	IEnumeration	
Access	Read / Write	
Unit	-	
Values	see table below	

Event	Event-ID	Description		
DeviceTemperatureStatusChanged	0x9030	Status of the internal device temperature has been changed.		
EventLost	0x9021	Event was lost in the camera.		
ExposureEnd	0x9001	Exposure ended.		
ExposureStart	0x9000	Exposure started.		
FrameEnd	0x9003	Device just completed the capture of one Frame.		
FrameStart	0x9002	Device just started the capture of one Frame.		
FrameTransfer-Skipped	0x9019	The event will be generated when the internal camera buffer is overflowed and and image has been lost.		
GigEVisionError	0x9020	Device just detected an error.		
GigEVisionHeartbeatTimeOut	0x9023	Device runs in heartbeat timeout.		
Line0FallingEdge	0x9008	Falling Edge is detected on the Line 0.		
Line0RisingEdge	0x9007	Rising Edge is detected on the Line 0.		
Line1FallingEdge	0x900A	Falling Edge is detected on the Line 1.		
Line1RisingEdge	0x9009	Rising Edge is detected on the Line 1.		
Line4FallingEdge	0x9010	Falling Edge is detected on the Line 4.		
Line4RisingEdge	0x900F	Rising Edge is detected on the Line 4.		
Line5FallingEdge	0x9012	Falling Edge is detected on the Line 5.		
Line5RisingEdge	0x9011	Rising Edge is detected on the Line 5.		
Line6FallingEdge	0x9014	Falling Edge is detected on the Line 6.		
Line6RisingEdge	0x9013	Rising Edge is detected on the Line 6.		
Line7FallingEdge	0x9016	Falling Edge is detected on the Line 7.		
Line7RisingEdge	0x9015	Rising Edge is detected on the Line 7.		
PrimaryApplication-Switch	0x0007	For systems where redundancy and fault recovery are required, it is often necessary for a second application to take control over the camera that is already under the control of a primary application. In order to notify the primary application that a switchover has occurred, send this event before granting access to new primary application.		
PtpServoStatus-Changed (≥ Rel. 2 only)	0x9032	The event will be generated when the status of the internal PTP servo has been changed.		
PtpStatusChanged (≥ Rel. 2 only)	0x9031	The event will be generated when the status of the internal PTP state machine has been changed.		
<table border="1" style="margin: auto;"> <thead> <tr> <th style="background-color: #0070C0; color: white;">Notice</th> </tr> </thead> <tbody> <tr> <td>There is a possibility that a large number of events <i>PtpStatusChanged</i> will be issued as long as <i>PtpServoStatus</i> ≠ <i>Locked</i>.</td> </tr> </tbody> </table>			Notice	There is a possibility that a large number of events <i>PtpStatusChanged</i> will be issued as long as <i>PtpServoStatus</i> ≠ <i>Locked</i> .
Notice				
There is a possibility that a large number of events <i>PtpStatusChanged</i> will be issued as long as <i>PtpServoStatus</i> ≠ <i>Locked</i> .				
TransferBufferFull	0x9017	The event will be generated when no internal camera buffer is available.		
TransferBuffer-Ready	0x9018	The event will be generated when an internal camera buffer is available again.		
TriggerOverlapped	0x9005	Trigger Overlapped.		
TriggerReady	0x9004	Camera is able to process incoming trigger.		
TriggerSkipped	0x9006	Camera reject an incoming trigger signal.		

7.11.3 LostEventCounter

Counts lost events.

Name	LostEventCounter
Category	EventControl
Interface	Integer
Access	Read only
Unit	-
Values	0 ... 9223372036854775807 (Increment: 1)

7.12 Category: HDRControl

This is the category that contains the Baumer HDR features.

HDR (**H**igh **D**ynamic **R**ange) is a technique that allows a greater dynamic range of luminance between the brightest and darkest areas of an image.

The HDR feature implemented here is based on the principle of interleaved readout of the sensor. Two different methods are used. The two different methods are described below.

The following cameras support the HDR function:

Camera Type	Gain-Controlled (row-based)	Exposure-Controlled (row-based)
Mono		
VLXT-06M.I	■	□
VLXT-17M.I	■	□
VLXT-28M.I	■	□
VLXT-55M.I	■	
VLXT-71M.I	■	□
VLXT-81M.I	■	□
VLXT-83UV.I	■	□
VLXT-126M.I	■	□
VLXT-240M.I	■	□
VLXT-490M.I (.EF) VLXN-490M.I.JP	□	■
VLXT-650M.I (.EF) VLXN-650M.I.JP	□	■

Operating principles

Gain-Controlled

Row {
1. } Gain A (*HDRGainBrightArea*) } same row
2. } Gain B (*HDRGainDarkArea*) } different gains

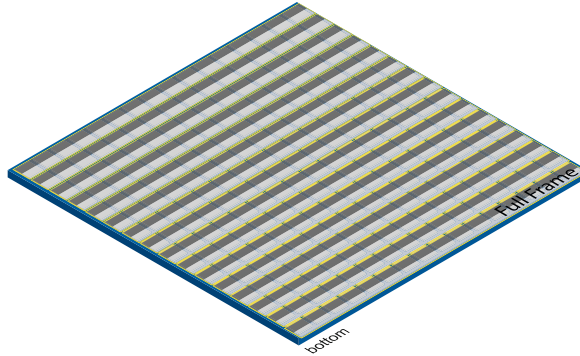

With this method the rows of the sensor are read out twice with different gains (Gain A / Gain B). The gain factor between Gain A and Gain B is set using the *HDRGainRatioSelector* feature.

By reading out the rows twice, an image with twice the height is generated. The image is calculated to the previous height, taking into account the different gains and can be adjusted with further settings (e.g. tone mapping).

Notice

Because each row is read out twice (Gain A / Gain B), the frame rate is halved.

Exposure-Controlled

Row 1 { } Exposure 1 (*HDRExposureTimeBrightArea*) } different rows and
Row 2 { } Exposure 2 (*HDRExposureTimeDarkArea*) } exposure times

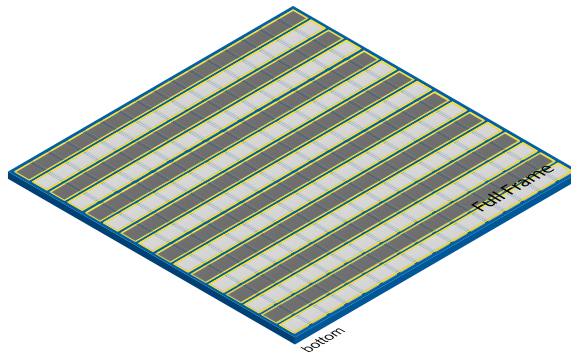

With this method every row of the sensor are read out with different exposure times (Exposure Time Row 1: *HDRExposureTimeBrightArea* / Exposure Time Row 2: *HDRExposureTimeDarkArea*).

The resulting image can be adjusted with further settings (e.g. tone mapping).

Notice

With this method, the number of rows read out is the same as for a non-HDR image. The framerate is unchanged.

How to set up HDR with Baumer Camera Explorer

1. Start the *Camera Explorer*. Open the camera. Select the profile *GenICam Guru* if necessary.
2. Make sure HDR is inactive (Category: HDRControl → `HDREnable = False`). Configure the lighting situation as it will be for the planned application.
3. Open the Diagram Tool [F7]. Activate the Selection. Select the brightest area in the image.

4. Set the exposure time (Category: AcquisitionControl → `ExposureTime`) of the camera so that the histogram peak value is between the values of 175 to 235.

→ Now you do not lose information in the bright area.

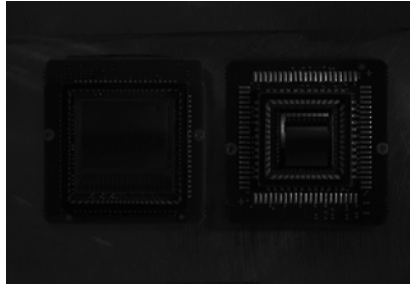

5. Stop the camera.

Notice

Do not use the feature (Category: AcquisitionControl → *AcquisitionStop*) in the feature tree.

This has other influences on the image acquisition too.

Use the button on the toolbar of the Camera Explorer or [F11].

6. Activate HDR (Category: HDRControl → `HDREnable = True`).

7. Gain-Controlled (row-based)

Select the gain ratio with the *HDRGainRatioSelector* feature.

Select the value for *HDRGainRatioSelector* so that the dark image areas contain sufficient gray value information.

Exposure-Controlled (row-based)

Select the exposure ratio with the *HDRExposureTimeRatio* feature.

Select the value for *HDRExposureTimeRatio* so that the dark image areas contain sufficient gray value information.

Notice

HDRGainRatioSelector is set by default to the value of 12dB (highest possible gain).

Notice

HDRExposureTimeRatio is set by default to the value of 16.

8. Start the camera again.

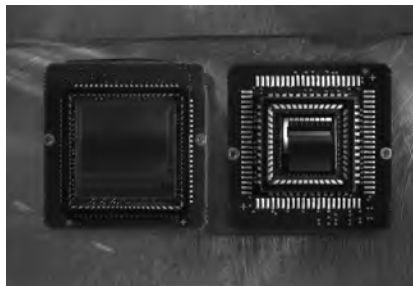

Notice

Do not use the feature (Category: AcquisitionControl → *AcquisitionStart*) in the feature tree.

This has other influences on the image acquisition too.

Use the button on the toolbar of the Camera Explorer or [F12].

Notice

If you want to output the direct image from the sensor, then deactivate the processing of the image data (`HDRProcessingEnable = False`).

Gain-Controlled (row-based)

A vertical subsampling is performed on the sensor image because the camera can not display twice the number of lines.

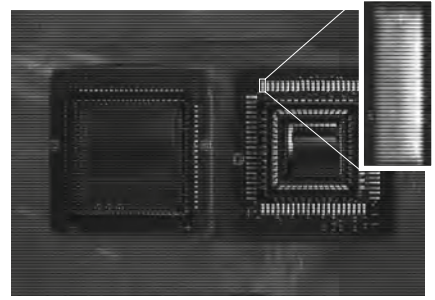

Gain-Controlled (row-based)

Notice

If you want to display the image information for (`HDRGainBrightArea = currently set value`) and (`HDRGainDarkArea = currently set value`) simultaneously, activate the SplitView feature (`HDRSplitView = True`).

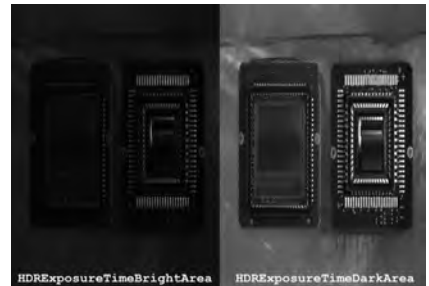

Exposure-Controlled (row-based)

Notice

If you want to display the image information for (`HDRExposureTimeDarkArea = current value`) and (`HDRExposureTimeBrightArea = current value`) simultaneously, activate the SplitView feature (`HDRSplitView = True`).

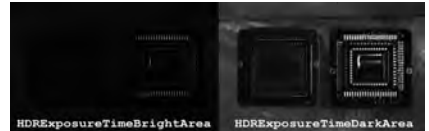

9. Exposure-Controlled (row-based)

With the features `HDRProcessingThresholdMax` and `HDRProcessingThresholdMin` you have further optional possibilities to influence the image.

- In the last step you have the option to influence the image via tone mapping.

Notice

To use tone mapping, the *HDRSplitView* feature must be disabled.

With tone mapping, the HDR (High Dynamic Range) image is converted to an LDR (Low Dynamic Range) image.

It does use a transfer function, which is approximated by up to 16 different linear sections.

Three presets are available (selectable via *HDRTonemappingCurvePresetSelector*).

[see chapter „7.12.13 Category: HDRTonemappingCurveControl“ on page 132](#)

- Execute the *HDR Tone MappingCurveResetToPreset* command to activate the selected preset.

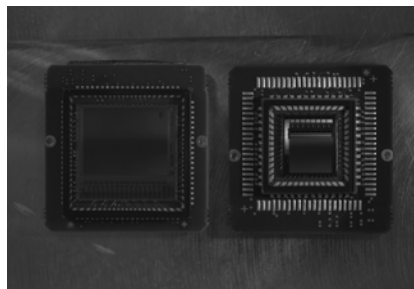
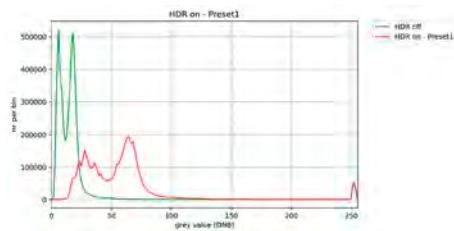

Histogram of the final image → more details in the dark areas

final image with tone mapping
(*HDRTonemappingCurvePresetSelector* = *Preset1*)

7.12.1 HDREnable

Enables the High Dynamic Range mode of the camera.

Notice

The camera must be stopped before feature can be set. HDR can not be used together with the Sequencer.

Name	HDREnable
Category	HDRControl
Interface	IBoolean
Access	Read / Write
Unit	-
Values	true = 1 (On) false = 0 (Off)

7.12.2 HDRExposureTimeBrightArea

Returns the exposure time for bright areas of image.

The following cameras support this function:

Camera Type	HDRExposureTimeBrightArea
Mono	
VLXT-490M.I (.EF) VLXN-490M.I.JP	■
VLXT-650M.I (.EF) VLXN-650M.I.JP	■
Name	HDRExposureTimeBrightArea
Category	HDRControl
Interface	IFloat
Access	Read only
Unit	μs
Values	20,000000 - 30,000,000.000000 (Increment: 1.00)

7.12.3 HDRExposureTimeDarkArea

Returns the exposure time for dark areas of image. This value represents the long exposure time, which is derived from short exposure time multiplied by *HDRExposureTimeRatio*.

The following cameras support this function:

Camera Type	HDRExposureTimeDarkArea
Mono	
VLXT-490M.I (.EF) VLXN-490M.I.JP	■
VLXT-650M.I (.EF) VLXN-650M.I.JP	■
Name	HDRExposureTimeDarkArea
Category	HDRControl
Interface	IFloat
Access	Read only
Unit	μs
Values	40,000000 - 60,000,000.000000 (Increment: 1.00)

7.12.4 HDRGainBrightArea

Returns the sensor gain for bright areas of image. This value represents the lower gain used as offset for the HDR image.

The following cameras support this function:

Camera Type	HDRGainBrightArea
Mono	
VLXT-06M.I	■
VLXT-17M.I	■
VLXT-28M.I	■
VLXT-55M.I	■
VLXT-71M.I	■
VLXT-81M.I	■
VLXT-83UV.I	■
VLXT-126M.I	■
VLXT-240M.I	■

Name	HDRGainBrightArea
Category	HDRControl
Interface	IFloat
Access	Read only
Unit	-
Values	1.000000 - 3.981072 (Increment: 0.10)

7.12.5 HDRGainDarkArea

Returns the sensor gain for dark areas of image. This value represents the higher gain, which is derived from lower gain and *HDRGainRatio*.

The following cameras support this function:

Camera Type	HDRGainDarkArea
Mono	
VLXT-06M.I	■
VLXT-17M.I	■
VLXT-28M.I	■
VLXT-55M.I	■
VLXT-71M.I	■
VLXT-81M.I	■
VLXT-83UV.I	■
VLXT-126M.I	■
VLXT-240M.I	■

Name	HDRGainDarkArea
Category	HDRControl
Interface	IFloat
Access	Read only
Unit	-
Values	1.000000 - 3.981072 (Increment: 0.10)

7.12.6 HDRGainRatio

Returns the gain ratio for HDR mode.

The following cameras support this function:

Camera Type	HDRGainRatio
Mono	
VLXT-06M.I	■
VLXT-17M.I	■
VLXT-28M.I	■
VLXT-55M.I	■
VLXT-71M.I	■
VLXT-81M.I	■
VLXT-83UV.I	■
VLXT-126M.I	■
VLXT-240M.I	■

Name	HDRGainRatio
Category	HDRControl
Interface	IFloat
Access	Read only
Unit	-
Values	1.000000 - 1.333521 (Increment: 0.10)

7.12.7 HDRExposureTimeRatio

Sets the exposure time ratio for HDR mode.

The following cameras support this function:

Camera Type	HDRExposureTimeRatio
Mono	
VLXT-490M.I (.EF)	■
VLXT-650M.I (.EF)	■

Name	HDRExposureTimeRatio
Category	HDRControl
Interface	Integer
Access	Read / Write
Unit	-
Values	2, 4, 8, 16, 32, 64, 128, 256, 512, 1024, 2048, 4096 (Increment: see value interval)
Values	Notice The maximum adjustable value depends on the exposure time of the camera.

7.12.8 HDRGainRatioSelector

Selects the gain ratio for HDR mode. The following cameras support this function:

Camera Type	HDRGainRatioSelector
Mono	
VLXT-06M.I	■
VLXT-17M.I	■
VLXT-28M.I	■
VLXT-55M.I	■
VLXT-71M.I	■
VLXT-81M.I	■
VLXT-83UV.I	■
VLXT-126M.I	■
VLXT-240M.I	■

Notice

The camera must be stopped before this feature can be set.

Notice

You can use the *HDRSplitviewEnable* feature to display a before and after image of your setting.

Name	HDRGainRatioSelector	
Category	HDRControl	
Interface	IEnumeration	
Access	Read / Write	
Unit	-	
Values	DynamicRange12_0dB	Sets HDR gain ratio to dynamic range of 12.0 dB. (Gain B 4 times higher than Gain A)
	DynamicRange2_5dB	Sets HDR gain ratio to dynamic range of 2.5 dB. (Gain B 1.33 times higher than Gain A)
	DynamicRange3_5dB	Sets HDR gain ratio to dynamic range of 3.5 dB. (Gain B 1.5 times higher than Gain A)
	DynamicRange6_0dB	Sets HDR gain ratio to dynamic range of 6.0 dB. (Gain B 2 times higher than Gain A)
	DynamicRange9_5dB	Sets HDR gain ratio to dynamic range of 9.5 dB. (Gain B 3 times higher than Gain A)
	Off	Sets HDR gain ratio to dynamic range of 0dB. (Gain B and Gain A the same)

7.12.9 HDRProcessingEnable

Enables the calculation of an interleaved HDR image of the sensor to an HDR image. If this feature is disabled while HDR is enabled the interleaved HDR image of the sensor will be output.

Name	HDRProcessingEnable	
Category	HDRControl	
Interface	IBoolean	
Access	Read / Write	
Unit	-	
Values	true = 1 (On)	
	false = 0 (Off)	

7.12.10 HDRProcessingThresholdMax

Specifies the upper threshold to determine valid pixels for HDR processing.

Notice

Pixels are valid if the brightness of the pixel is within the set range. If the brightness is outside the range, the pixels of the neighboring rows are used for HDR processing.

The following cameras support this function:

Camera Type	HDRProcessingThresholdMax
Mono	
VLXT-650M.I (.EF)	■
VLXT-650M.I (.EF)	■
Name	HDRProcessingThresholdMax
Category	HDRControl
Interface	Integer
Access	Read / Write
Unit	-
Values	2048 ... 4095 (Increment: 1)

7.12.11 HDRProcessingThresholdMin

Specifies the lower threshold to determine valid pixels for HDR processing.

Notice

Pixels are valid if the brightness of the pixel is within the set range. If the brightness is outside the range, the pixels of the neighboring rows are used for HDR processing.

The following cameras support this function:

Camera Type	HDRProcessingThresholdMin
Mono	
VLXT-490M.I (.EF)	■
VLXN-490M.I.JP	
VLXT-650M.I (.EF)	■
VLXT-650N.I.JP	
Name	HDRProcessingThresholdMin
Category	HDRControl
Interface	Integer
Access	Read / Write
Unit	-
Values	0 ... 2047 (Increment: 1)

7.12.12 HDRSplitviewEnable

Gain-Controlled (row-based)

After activating this function, the image for (HDRGainBrightArea) is displayed in the left area and the image for (HDRGainDarkArea) is displayed in the right area.

This view helps to better adjust the *HDRGainRatioSelector*.

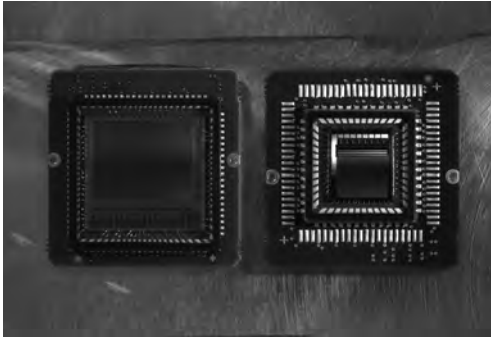

HDRSplitviewEnable = Off

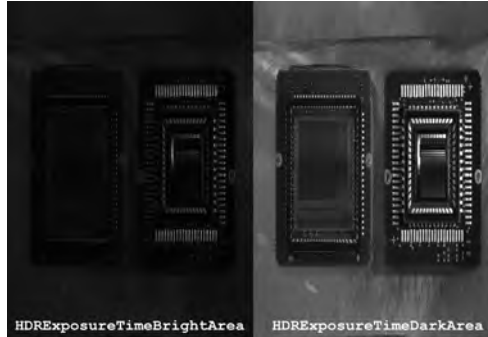

HDRSplitviewEnable = On
(HDRGainRatioSelector = 12.0 dB)

Exposure-Controlled (row-based)

After activating this function, the image for (HDRExposureTimeBrightArea) is displayed in the left area and the image for (HDRExposureTimeDarkArea) is displayed in the right area.

This view helps to better adjust the *HDRExposureTimeRatio*.

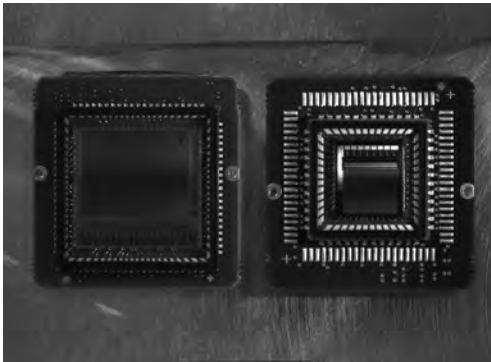

HDRSplitviewEnable = Off



HDRSplitviewEnable = On
(HDRExposureTimeRatio = 4)

Name	HDRSplitviewEnable
Category	HDRControl
Interface	IBoolean
Access	Read / Write
Unit	-
Values	true = 1 (On) false = 0 (Off)

7.12.13 Category: HDRTonemappingCurveControl

This category contains the Baumer HDR tone mapping curve control features.

With tone mapping, the HDR (High Dynamic Range) image is converted to an LDR (Low Dynamic Range) image.

Notice

The internal processing is done on 12 bit, therefore the HDR tone mapping is always applied to 12 bit LDR.

Three presets are available (selectable via *HDRTonemappingCurvePresetSelector*).

Additionally, you can also create your own transfer function for the tone mapping by setting values of:

- HDRTonemappingCurveOffset
- HDRTonemappingCurveGradient
- HDRTonemappingCurveGridpoint

for each of the 16 indices of HDRTonemappingCurveGridpoint.

The following graphic shows an example, how each value influence the characteristics of the HDR tone mapping curve.

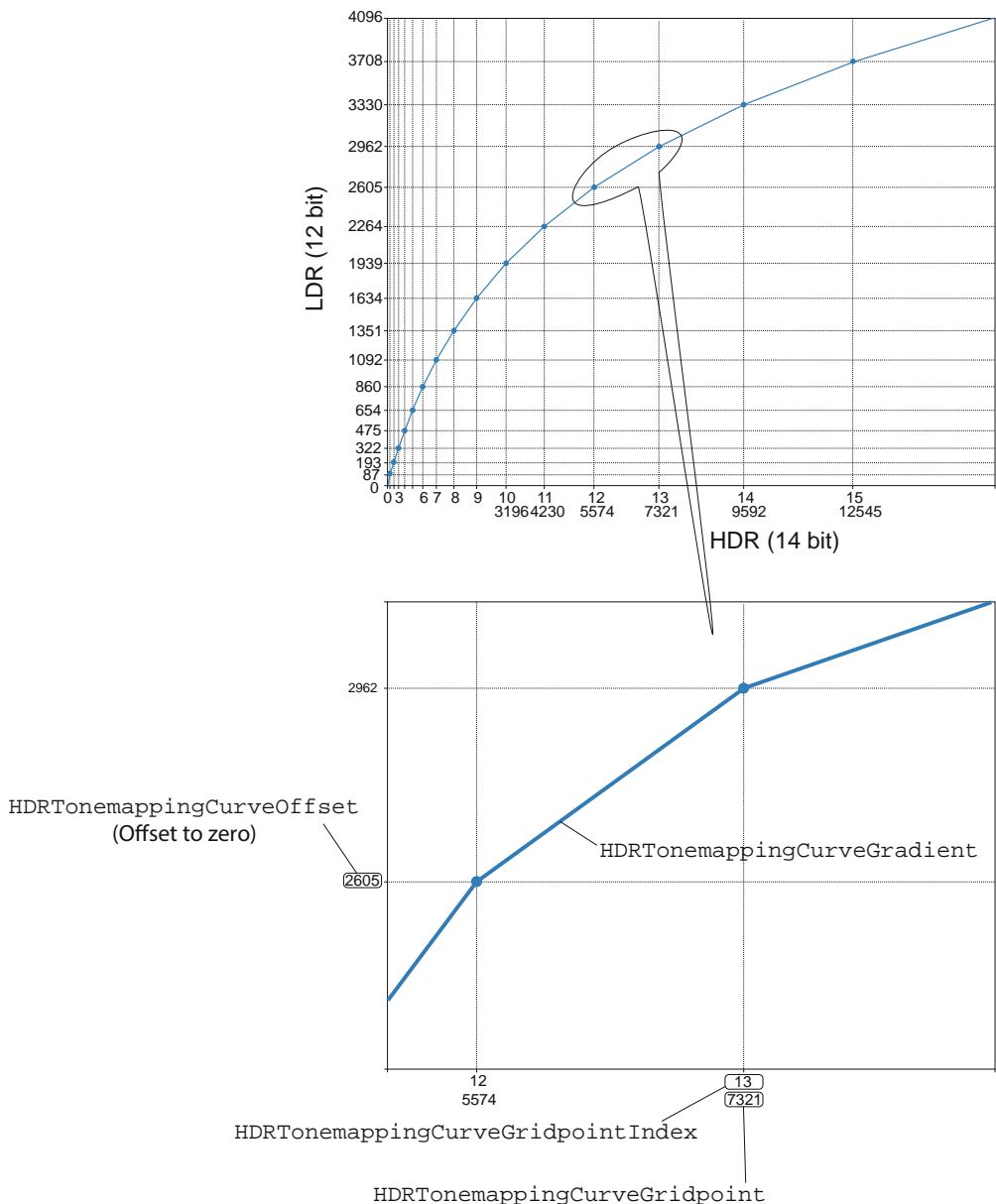

7.12.13.1 HDRTonemappingCurveGradient

Sets the gradient at selected grid point for HDR tone-mapping transfer curve.

Name	HDRTonemappingCurveGradient
Category	HDRControl → HDRTonemappingCurveControl
Interface	IFloat
Access	Read / Write
Unit	-
	0 - 0.9999842587890625 (Increment: 0.00001451757)
Values	Notice Rounded values are displayed in the <i>Feature control area</i> of <i>Camera Explorer</i> . You can read the exact values in the <i>System Status / Log View</i> of the <i>Camera Explorer</i> .

7.12.13.2 HDRTonemappingCurveGridpoint

Sets the grid point for HDR tone-mapping transfer curve.

Name	HDRTonemappingCurveGridpoint
Category	HDRControl → HDRTonemappingCurveControl
Interface	Integer
Access	Read / Write
Unit	-
	0 ... 16383 (Gain-Controlled) / 16777215 (Exposure-Controlled) (Increment: 1)
Values	Notice The adjustable maximum depends on the respective ratio. <ul style="list-style-type: none">▪ Gain-Controlled (<code>HDRGainRatio</code>)▪ Exposure-Controlled (<code>HDRExposureTimeRatio</code>)

7.12.13.3 HDRTonemappingCurveGridpointIndex

Sets the index of grid point for the user-defined tone-mapping curve.

Name	HDRTonemappingCurveGridpointIndex
Category	HDRControl → HDRTonemappingCurveControl
Interface	Integer
Access	Read / Write
Unit	-
Values	0 ... 15 (Increment: 1)

7.12.13.4 HDRTonemappingCurveOffset

Sets the offset at selected grid point for HDR tone-mapping transfer curve.

Name	HDRTonemappingCurveOffset
Category	HDRControl → HDRTonemappingCurveControl
Interface	Integer
Access	Read / Write
Unit	-
Values	0 ... 4095 (Increment: 1)

7.12.14 HDRTonemappingCurvePresetSelector

Selects the predefined transfer curve for global tone-mapping of the calculated HDR image.

Notice

The selected preset is stored in the user set.

The following diagram shows the characteristics of the selectable presets.

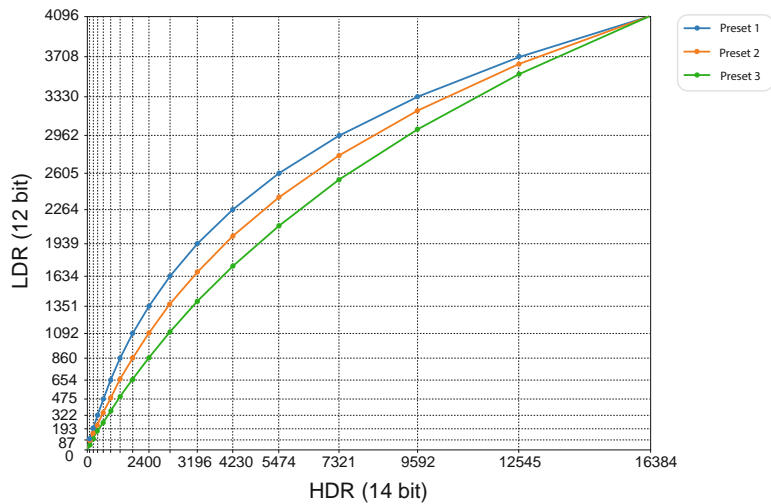

Name	HDRTonemappingCurvePresetSelector
Category	HDRControl
Interface	IEnumeration
Access	Read / Write
Unit	-
Values	Preset1 The HDR tone-mapping preset for a steep logarithmic transfer curve will be used.
	Preset2 The HDR tone-mapping preset for a middle step logarithmic transfer curve will be used.
	Preset3 The HDR tone-mapping preset for a slight logarithmic transfer curve will be used.

7.12.15 HDRTonemappingCurveResetToPreset

Reset the tone-mapping curve to the selected HDRTonemappingCurvePreset.

Name	HDRTonemappingCurveResetToPreset
Category	HDRControl
Interface	ICommand
Access	Write only
Unit	-
Values	-

7.12.16 HDRTonemappingEnable

Enables the tone-mapping of calculated HDR image. If this feature is deactivated HDR pixels are only cut to width of specified output pixelformat and HDR information will be lost.

Notice

The settings for tone mapping are made in the *HDR Tone Mapping Curve Control* category.

Notice

To use tone mapping, the *HDR Split View* feature must be disabled.

Name	HDRTonemappingEnable
Category	HDRControl
Interface	IBoolean
Access	Read / Write
Unit	-
Values	true = 1 (On) false = 0 (Off)

7.13 Category: ImageFormatControl

This chapter describes how to influence and determine the image size and format.

Region of Interest (OffsetX / OffsetY / Width / Height) - General Information

You can use the "Region of Interest" (ROI) function to predefine a so-called region of interest or partial scan. This ROI is an area of pixels on the sensor. When an image is acquired, only the information regarding these pixels is transferred to the PC. Not all of the lines on the sensor are read out, which therefore decreases the readout time (t_{readout}). This increases the frame rate.

This function is used if only a particular region of the field of view is of interest. It also reduces the resolution.

The ROI is specified using four values:

- OffsetX - x-coordinate of the first relevant pixel
- OffsetY - y-coordinate of the first relevant pixel
- Width - horizontal size of the ROI
- Height - vertical size of the ROI

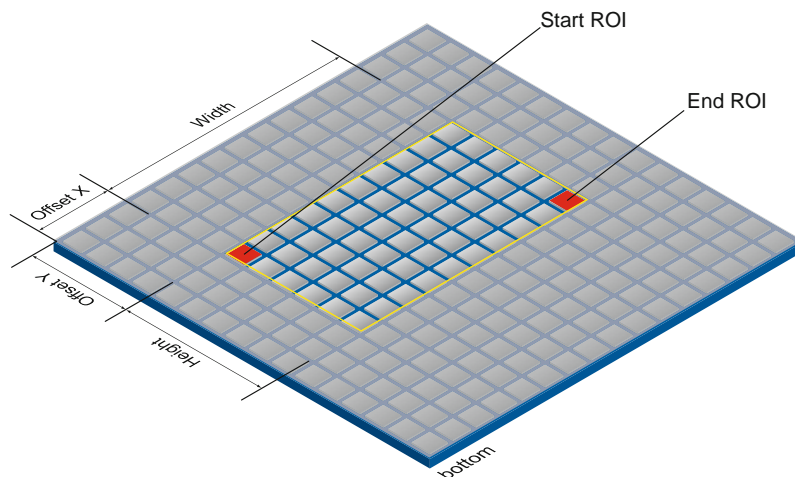

ROI Readout

In the illustration below, the readout time would decrease to 40% of a full frame readout.

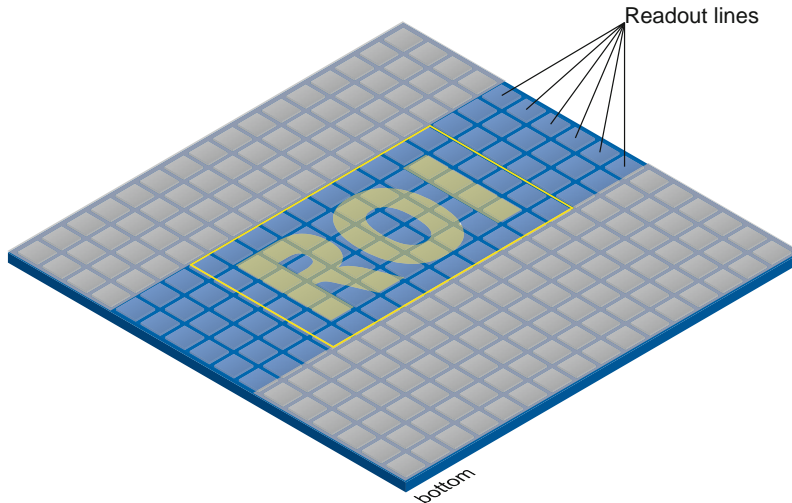

Multi Region of Interest (RegionMode / RegionSelector / OffsetX / OffsetY / Width / Height) - General Information (≥ Release 3 only)

With Multi-ROI it is possible to predefine several Region of Interests (ROIs). It can be specified up to 8 ROIs. Overlapped Multi-ROIs and Multi-ROIs that are next to each other are not possible. Multi-ROIs which are among each other are possible. All Multi-ROIs must have the same width, but the height may vary.

The camera only reads out sensor parts that are within one of the active Multi-ROI's and transferred all Multi-ROIs in one frame.

Notice

It is not possible to use AutoFeature-ROI and Multi-ROI together. Multi-ROI cannot be used simultaneously with *Binning*, *Seqencer*, *Shading* and *PixelFormat* RGB / BGR.

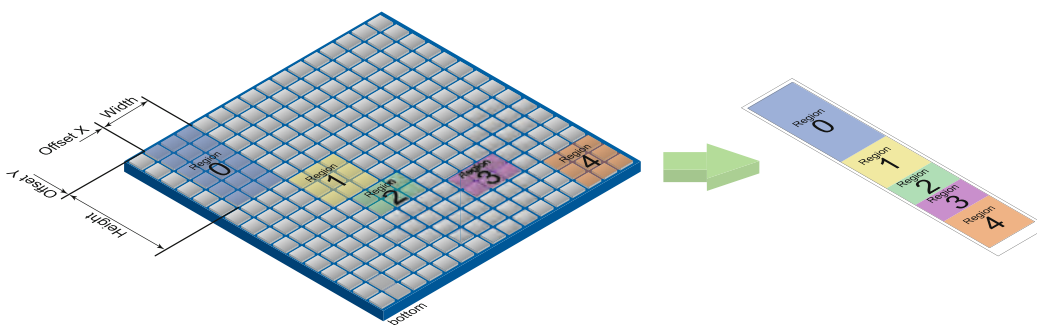

Width = Width = Width = Width = Width
 (Region 0) (Region 1) (Region 2) (Region 3) (Region 4)
 (Example with 5 ROI's. Maximum 8 ROI's are possible.)

Decimation (DecimationHorizontal / DecimationHorizontalMode / DecimationVertical / DecimationVerticalMode) - General Information

In this mode, the sensor is read out partially. Thus the frame rate is increased and the amount of data transferred is reduced.

It is available for mono and color cameras. With color cameras, a color correct readout of the pixels takes place.

Notice

Decimation can not be used simultaneously with *Binning*, *Seqencer* or *HDR*.

Decimation	Illustration		Example
	color	mono	
<p>without</p> <p>Full frame image, no decimation of pixels</p>			
<p>1x2</p> <p>Vertical decimation causes a vertically compressed image</p>			
<p>2x1</p> <p>Horizontal decimation causes a horizontally compressed image</p>			
<p>2x2</p> <p>Bidirectional decimation causes a horizontal and vertically compressed image</p>			

7.13.1 BinningHorizontal

Number of horizontal photo-sensitive cells to combine together. This increases the intensity (or signal to noise ratio) of the pixels and reduces the horizontal resolution (width) of the image.

Name	BinningHorizontal
Category	ImageFormatControl
Interface	Integer
Access	Read / Write
Unit	-
Values	see table below (Increment: 1)

Camera Type	BinningSelector [Region0]	BinningSelector [Sensor]
Monochrome		
VLXT-06M.I (.JP)	1 ... 2	1 ... 1
VLXT-17M.I	1 ... 2	1 ... 1
VLXT-28M.I (.JP)	1 ... 2	1 ... 1
VLXT-31M(.I) (.JP) (.FO)	1 ... 2	1 ... 1
VLXT-50M(.I) (.FO)	1 ... 2	1 ... 1
VLXT-55M.I	1 ... 2	1 ... 2*
VLXT-71M.I	1 ... 2	1 ... 1
VLXT-81M.I	1 ... 2	1 ... 2*
VLXT-83UV.I	1 ... 2	1 ... 2*
VLXT-90M(.I) (.JP) (.FO)	1 ... 2	1 ... 2*
VLXT-123M(.I) (.FO)	1 ... 2	1 ... 2*
VLXT-126M.I	1 ... 2	1 ... 2*
VLXT-240M.I	1 ... 2	1 ... 2*
VLXT-490M.I (.EF) VLXN-490M.I.JP	1 ... 2	1 ... 1
VLXT-650M.I (.EF) (.JP) VLXN-650M.I.JP	1 ... 2	1 ... 1
Color		
VLXT-06C.I.JP	1 ... 2	1 ... 1
VLXT-31C.I (.JP)	1 ... 2	1 ... 1
VLXT-50C(.I) (.FO)	1 ... 2	1 ... 1
VLXT-55C.I	1 ... 2	1 ... 1
VLXT-71C.I	1 ... 2	1 ... 1
VLXT-81C.I	1 ... 2	1 ... 1
VLXT-90C.I	1 ... 2	1 ... 1
VLXT-123C.I	1 ... 2	1 ... 1
VLXT-126C.I	1 ... 2	1 ... 1
VLXT-240C.I	1 ... 2	1 ... 1
VLXT-490C.I (.EF)	1 ... 2	1 ... 1
VLXT-650C.I (.EF)	1 ... 2	1 ... 1

*¹) *BinningVertical* is also switched to 2

7.13.2 BinningHorizontalMode

Sets the mode to use to combine horizontal photo-sensitive cells together when BinningHorizontal is used.

Name	BinningHorizontalMode	
Category	ImageFormatControl	
Interface	IEnumeration	
Access	Read / Write	
Unit	-	
Values	Average	The response from the combined cells will be averaged, resulting in increased signal/noise ratio.
	Sum	The response from the combined cells will be added, resulting in increased sensitivity.

7.13.3 BinningSelector

Selects which binning engine is controlled by the BinningHorizontal and BinningVertical features.

Notice
(≥ Release 3 only)
 Binning can not be used simultaneously with Multi-ROI.

Name	BinningSelector	
Category	ImageFormatControl	
Interface	IEnumeration	
Access	Read / Write	
Unit	-	
Values	Region0	Selected feature will control the region 0 (FPGA) binning.
	Sensor	Selected features will control the sensor binning.

Known issues

The following models are affected:

- VLXT-28M.x
- VLXT-71M.x
- VLXT-90M.x
- VLXT-123M.x

Due to the sensor applied, some camera models have an offset of one pixel when binning performed in the sensor (`BinningSelector = [Sensor]`).

This behavior also occurs with a set Region of Interest (ROI).

Use binning via the FPGA (`BinningSelector = [Region0]`) if this behavior occurs in your application.

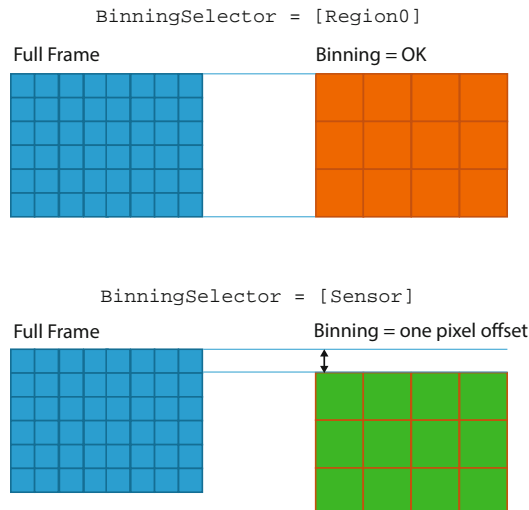

7.13.4 BinningVertical

Number of vertical photo-sensitive cells to combine together. This increases the intensity (or signal to noise ratio) of the pixels and reduces the vertical resolution (height) of the image.

Name	BinningVertical
Category	ImageFormatControl
Interface	Integer
Access	Read / Write
Unit	-
Values	see table below (Increment: 1)

Camera Type	BinningSelector [Region0]	BinningSelector [Sensor]
Monochrome		
VLXT-06M.I (.JP)	1 ... 2	1 ... 1
VLXT-17M.I	1 ... 2	1 ... 1
VLXT-28M.I (.JP)	1 ... 2	1 ... 1
VLXT-31M(.I) (.JP) (.FO)	1 ... 2	1 ... 1
VLXT-50M(.I) (.FO)	1 ... 2	1 ... 1
VLXT-55M.I	1 ... 2	1 ... 2*
VLXT-71M.I	1 ... 2	1 ... 1
VLXT-81M.I	1 ... 2	1 ... 2*
VLXT-83UV.I	1 ... 2	1 ... 2*
VLXT-90M(.I) (.JP) (.FO)	1 ... 2	1 ... 2*
VLXT-123M(.I) (.FO)	1 ... 2	1 ... 2*
VLXT-126M.I	1 ... 2	1 ... 2*
VLXT-240M.I	1 ... 2	1 ... 2*
VLXT-490M.I (.EF)	1 ... 2	1 ... 1
VLXN-490M.I.JP	1 ... 2	1 ... 1
VLXT-650M.I (.EF)	1 ... 2	1 ... 1
VLXN-650M.I.JP	1 ... 2	1 ... 1
Color		
VLXT-06C.I.JP	1 ... 2	1 ... 1
VLXT-31C.I (.JP)	1 ... 2	1 ... 1
VLXT-50C(.I) (.FO)	1 ... 2	1 ... 1
VLXT-55C.I	1 ... 2	1 ... 1
VLXT-71C.I	1 ... 2	1 ... 1
VLXT-81C.I	1 ... 2	1 ... 1
VLXT-90C.I	1 ... 2	1 ... 1
VLXT-123C.I	1 ... 2	1 ... 1
VLXT-126C.I	1 ... 2	1 ... 1
VLXT-240C.I	1 ... 2	1 ... 1
VLXT-490C.I (.EF)	1 ... 2	1 ... 1
VLXT-650C.I (.EF)	1 ... 2	1 ... 1

*) *BinningHorizontal* is also switched to 2

7.13.5 BinningVerticalMode

The response from the combined cells will be averaged, resulting in increased signal/noise ratio.

Name	BinningHorizontalMode	
Category	ImageFormatControl	
Interface	IEnumeration	
Access	Read / Write	
Unit	-	
Values	Average	The response from the combined cells will be averaged, resulting in increased signal/noise ratio.
	Sum	The response from the combined cells will be added, resulting in increased sensitivity.

7.13.6 DecimationHorizontal

Horizontal sub-sampling of the image. This reduces the horizontal resolution (width) of the image by the specified horizontal decimation factor.

Name	DecimationHorizontal	
Category	ImageFormatControl	
Interface	IInteger	
Access	Read / Write	
Unit	-	
Values	see table below	

Camera Type

Monochrome

VLXT-490M.I (.EF) 1 ... 2 (Increment 1)

VLXT-650M.I (.EF) 1 ... 2 (Increment 1)

Color

VLXT-490C.I (.EF) 1 ... 2 (Increment 1)

VLXT-650C.I (.EF) 1 ... 2 (Increment 1)

7.13.7 DecimationHorizontalMode

Sets the mode used to reduce the horizontal resolution when DecimationHorizontal is used.

Name	DecimationHorizontalMode	
Category	ImageFormatControl	
Interface	IEnumeration	
Access	Read / Write	
Unit	-	
Values	Discard	The value of every nth pixel is kept, others are discarded.

7.13.8 DecimationVertical

Vertical sub-sampling of the image. This reduces the vertical resolution (height) of the image by the specified vertical decimation factor.

Name	DecimationVertical
Category	ImageFormatControl
Interface	IInteger
Access	Read / Write
Unit	-
Values	see table below

Camera Type	
Monochrome	
VLXT-490M.I (.EF)	1 ... 2 (Increment 1)
VLXT-650M.I (.EF)	1 ... 2 (Increment 1)
Color	
VLXT-490C.I (.EF)	1 ... 2 (Increment 1)
VLXT-650C.I (.EF)	1 ... 2 (Increment 1)

7.13.9 DecimationVerticalMode

Sets the mode used to reduce the vertical resolution when DecimationVertical is used.

Name	DecimationVerticalMode	
Category	ImageFormatControl	
Interface	IEnumeration	
Access	Read / Write	
Unit	-	
Values	Discard	The value of every Nth pixel is kept, others are discarded.

7.13.10 Height

Height of the image provided by the device (in pixels). The selected value changes with the change of *Binning*.

Notice

The sum of *Offset Y* and *Height* must be smaller or equal than *Height Max*.

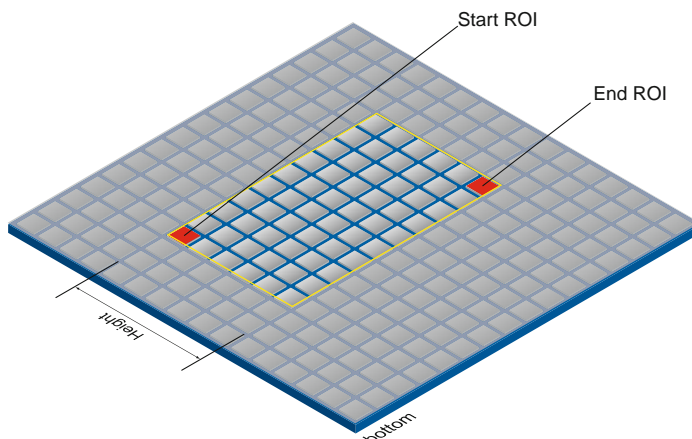

Name	Height
Category	ImageFormatControl
Interface	Integer
Access	Read / Write
Unit	-
Values	see table below

Camera Type

Monochrome

VLXT-06M.I (.JP)	1 ... 620 (Increment: 1)
VLXT-17M.I	1 ... 1100 (Increment: 1)
VLXT-28M.I (.JP)	1 ... 1464 (Increment: 1)
VLXT-31M.I (.JP) (.FO)	1* 2 ... 1536 (Increment: 1* 2)
VLXT-50M.I (.FO)	1* 2 ... 2048 (Increment: 1* 2)
VLXT-55M.I	1 ... 2048 (Increment: 1)
VLXT-71M.I	1 ... 2200 (Increment: 1)
VLXT-81M.I	1 ... 2832 (Increment: 1)
VLXT-83UV.I	1 ... 2832 (Increment: 1)
VLXT-90M.I (.JP) (.FO)	1* 4 ... 2160 (Increment: 1* 4)
VLXT-123M.I (.FO)	1* 4 ... 3000 (Increment: 1* 4)
VLXT-126M.I	1 ... 2992 (Increment: 1)
VLXT-240M.I	1 ... 4600 (Increment: 1)
VLXT-490M.I (.EF) VLXN-490M.I.JP	1 ... 7000 (Increment: 1)
VLXT-650M.I (.EF) VLXN-650M.I.JP	1 ... 7000 (Increment: 1)

Color

VLXT-06C.I.JP	1 ... 608 (Increment: 2)
VLXT-31C.I (.JP)	2* 4 ... 1536 (Increment: 2* 4)
VLXT-50C.I (.FO)	2* 4 ... 2048 (Increment: 2* 4)
VLXT-55C.I	2 ... 2048 (Increment: 2)
VLXT-71C.I	2 ... 2200 (Increment: 2)
VLXT-81C.I	2 ... 2832 (Increment: 2)
VLXT-90C.I	2* 4 ... 2160 (Increment: 2* 4)
VLXT-123C.I	2* 4 ... 3000 (Increment: 2* 4)
VLXT-126C.I	2 ... 2992 (Increment: 2)
VLXT-240C.I	2... 4592 (Increment: 2)
VLXT-490C.I (.EF)	2... 7000 (Increment: 2)
VLXT-650C.I (.EF)	2 ... 7000 (Increment: 2)

*) ≥ Release 2

7.13.11 HeightMax

Maximum height of the image (in pixels). This dimension is calculated after vertical binning, decimation or any other function changing the vertical dimension of the image.

Name	HeightMax
Category	ImageFormatControl
Interface	Integer
Access	Read only
Unit	-
Values	see table below

Camera Type	
Monochrome	
VLXT-06M.I (.JP)	620
VLXT-17M.I	1100
VLXT-28M.I (.JP)	1464
VLXT-31M(.I) (.FO)	1536
VLXT-50M(.I) (.FO)	2048
VLXT-55M.I	2048
VLXT-71M.I	2200
VLXT-81M.I	2832
VLXT-83UV.I	2832
VLXT-90M(.I) (.JP) (.FO)	2160
VLXT-123M(.I) (.FO)	3000
VLXT-126M.I	2992
VLXT-240M.I	4600
VLXT-490M.I (.EF) VLXN-490M.I.JP	7000
VLXT-650M.I (.EF) VLXN-650M.I.JP	7000
Color	
VLXT-06C.I.JP	608
VLXT-31C.I (.JP)	1536
VLXT-50C(.I) (.FO)	2048
VLXT-55C.I	2048
VLXT-71C.I	2200
VLXT-81C.I	2832
VLXT-90C.I	2160
VLXT-123C.I	3000
VLXT-126C.I	2992
VLXT-240C.I	4600
VLXT-490C.I (.EF)	7000
VLXT-650C.I (.EF)	7000

7.13.12 ImageCompressionBitRate (VLXN only)

Notice

To set ImageCompressionBitRate, set Image Compression Rate Option = Fix Bitrate.

Notice

The camera must be stopped before feature can be changed.

Controls the rate of the produced compressed stream.

Name	ImageCompressionBitRate
Category	ImageFormatControl
Interface	IFloat
Access	Read / Write
Unit	Mbps
Values	1.000000 ... 1,000.000000 (Increment: 1,00)

7.13.13 ImageCompressionJPEGFormatOption (.JP cameras only)

When JPEG is selected as the compression format, a device might optionally offer better control over JPEG-specific options through this feature.

Name	ImageCompressionJPEGFormatOption
Category	ImageFormatControl
Interface	IEnumeration
Access	Read / Write
Unit	-
Values	Baseline Standard Indicates this is a baseline sequential (single-scan) DCT-based JPEG.

7.13.14 ImageCompressionMode (.JP cameras only)

Enables a specific image compression mode as the base mode for image transfer. Optionally, chunk data can be appended to the compressed image.

Notice

The camera must be stopped before feature can be changed.

Notice

To set `ImageCompressionMode = JPEG`, a pixel format that supports compression must be selected first.

Supported pixel formats:

Mono cameras: Mono8

Color cameras: Mono8, YCbCr422_8

Name	ImageCompressionMode	
Category	ImageFormatControl	
Interface	IEnumeration	
Access	Read / Write	
Unit	-	
Values	JPEG	JPEG compression is selected.
	Off	Image compression is disabled. Images are transmitted uncompressed.

7.13.15 ImageCompressionQuality (.JP cameras only)

Controls the quality of the produced compressed stream.

Notice

The camera must be stopped before feature can be changed.

Name	ImageCompressionQuality
Category	ImageFormatControl
Interface	Integer
Access	Read / Write
Unit	-
	10 ... 95 (Increment: 1)
Values	Notice
	10 = highest compression rate / 95 = lowest compression rate

Examples

ImageCompressionQuality = 85 (low compression rate)

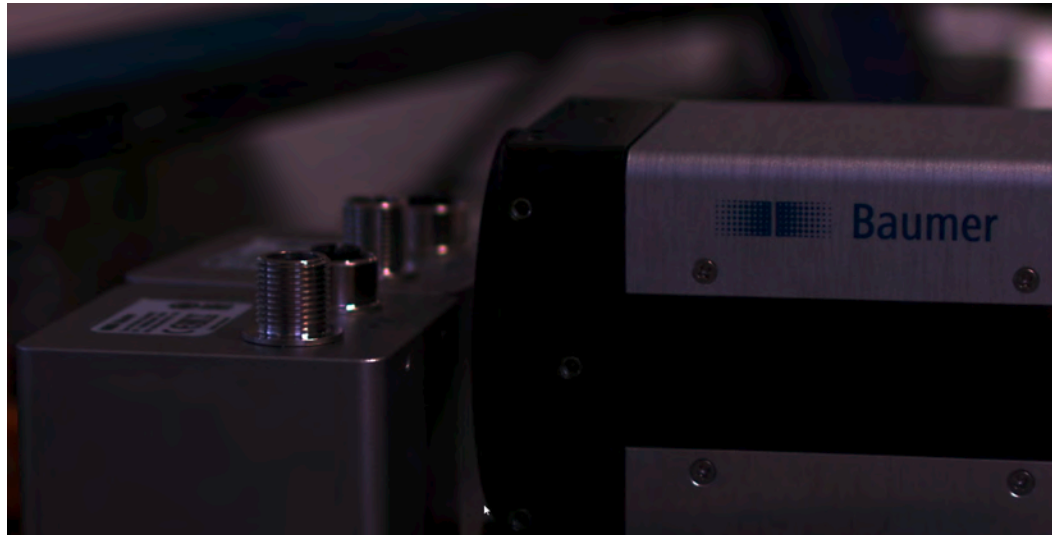

ImageCompressionQuality = 30

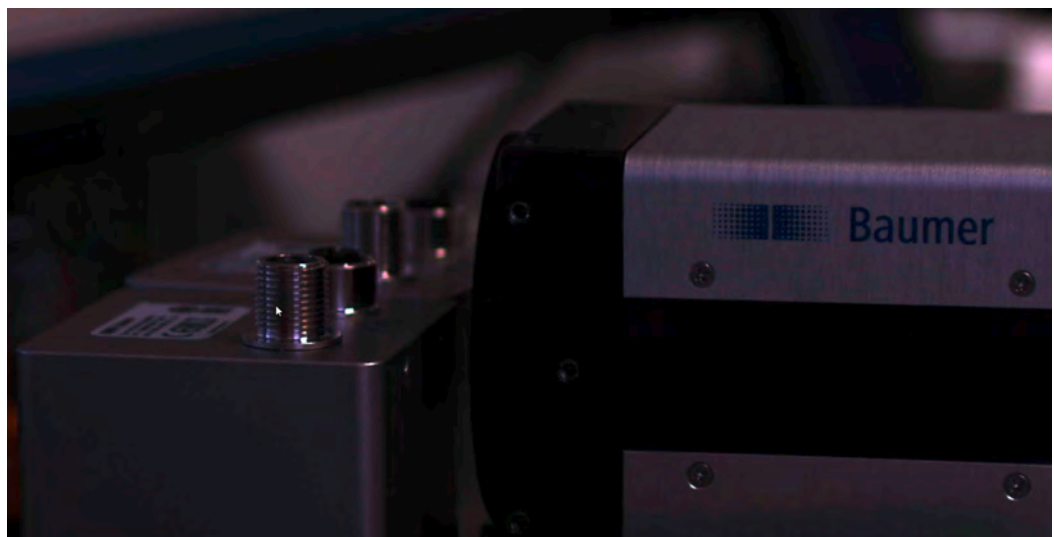

ImageCompressionQuality = 10 (highest compression rate)

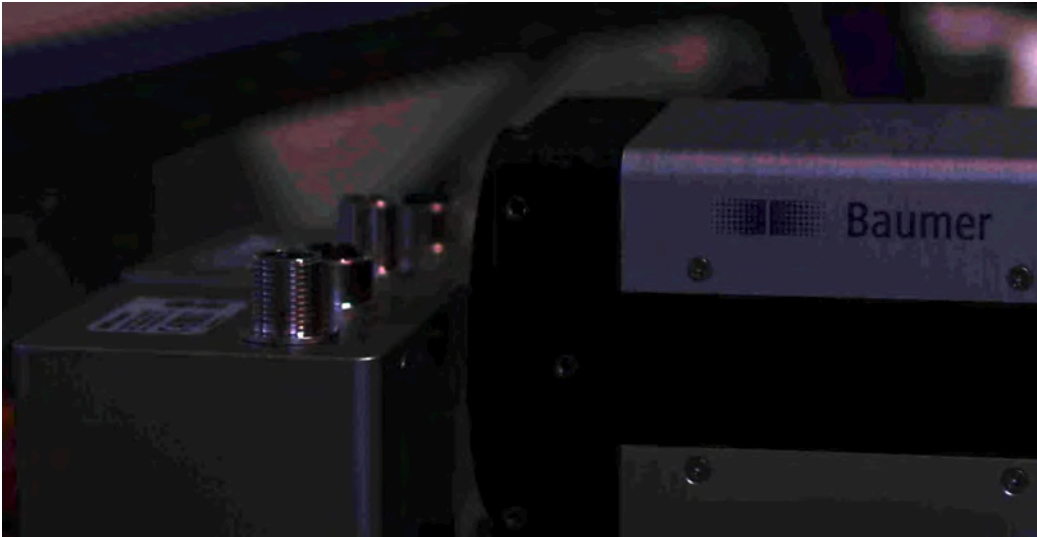

7.13.16 ImageCompressionRateOption (.JP cameras only)

With this feature you can set the quality of the output stream. Two rate controlling options are offered: fixed bit rate or fixed quality (VLXN only). The exact implementation to achieve one or the other is vendor-specific.

Name	ImageCompressionJPEGFormatOption	
Category	ImageFormatControl	
Interface	IEnumeration	
Access	Read / Write	
Unit	-	
Values	Fix Bitrate (VLXN only)	Output stream follows a constant bit rate. Allows easy bandwidth management on the link.
	Fix Quality	Output stream has a constant image quality. Can be used when image processing algorithms are sensitive to image degradation caused by excessive data compression.

7.13.17 OffsetX

Horizontal offset from the origin to the region of interest (in pixels).

Notice

The sum of *OffsetX* and *Width* must be smaller or equal than *WidthMax*.

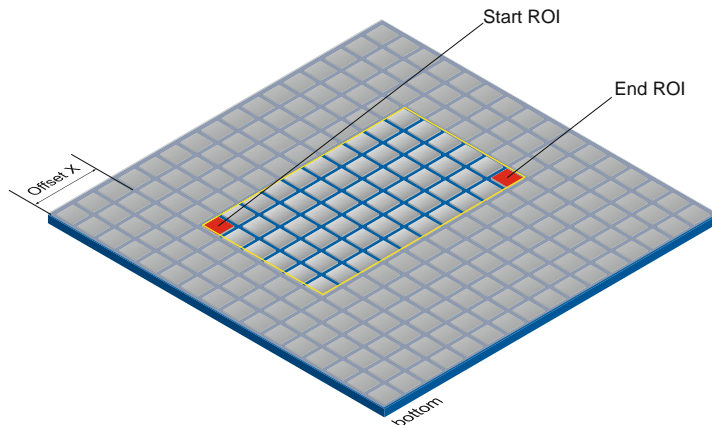

Name	OffsetX
Category	ImageFormatControl
Interface	Integer
Access	Read / Write
Unit	-
Values	0 - depends on setted <i>Width</i> (Increment: 32)

7.13.18 OffsetY

Vertical offset from the origin to the region of interest (in pixels).

Notice

The sum of *OffsetY* and *Height* must be smaller or equal than *HeightMax*.

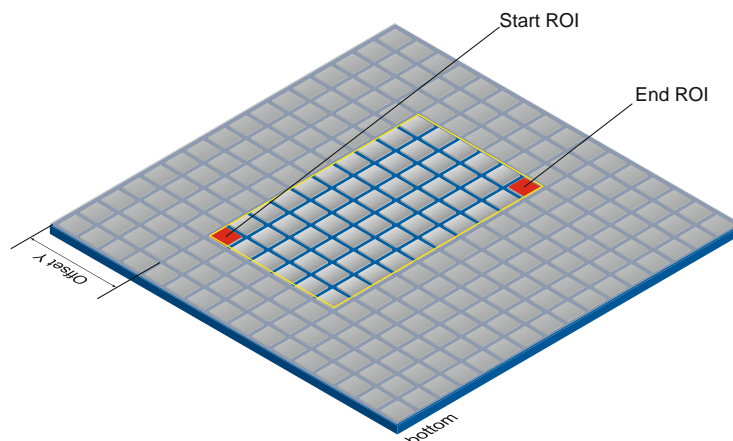

Name	OffsetY
Category	ImageFormatControl
Interface	Integer
Access	Read / Write
Unit	-
Values	0 - depends on setted <i>Height</i> (Increment: 4)

7.13.19 PixelFormat

Format of the pixels provided by the device. It represents all the information provided by PixelCoding, PixelSize, PixelColorFilter combined in a single feature.

General Information

RAW: Raw data format. Here the data is stored without processing.

Bayer: Raw data format of color sensors.

Color filters are placed on these sensors in a checkerboard pattern, generally in a 50% green, 25% red and 25% blue array.

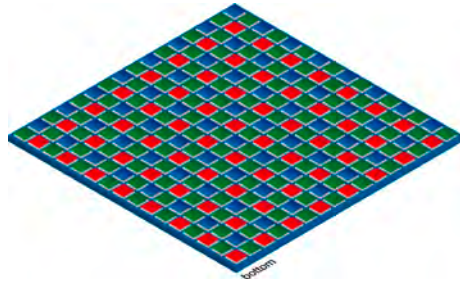

Mono: Monochrome. The color range of mono images consists of shades of a single color. In general, shades of gray or black-and-white are synonyms for monochrome.

RGB: Color model, in which all detectable colors are defined by three coordinates, Red, Green and Blue.

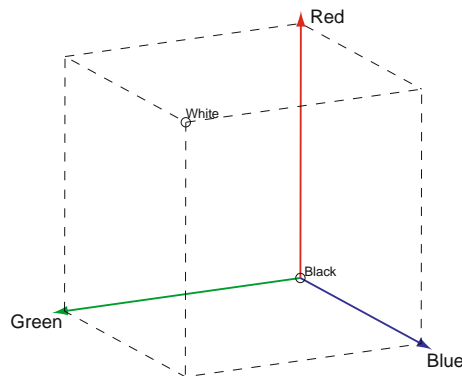

The three coordinates are displayed within the buffer in the order R, G, B.

BGR: At BGR the interface of the camera mirrors the order of transmission of the color channels from RGB to BGR.

This can save processing power on the computer, because these data can be processed by the graphic card without conversion.

Pixel depth: In general, pixel depth defines the number of possible different values for each color channel. Mostly this will be 8 bit, which means 2^8 different "colors".

For RGB or BGR these 8 bits per channel equal 24 bits overall.

Two bytes are needed for transmitting more than 8 bits per pixel - even if the second byte is not completely filled with data. In order to save bandwidth, the packed formats were introduced to Baumer cameras. In this formats, the unused bits of one pixel are filled with data from the next pixel.

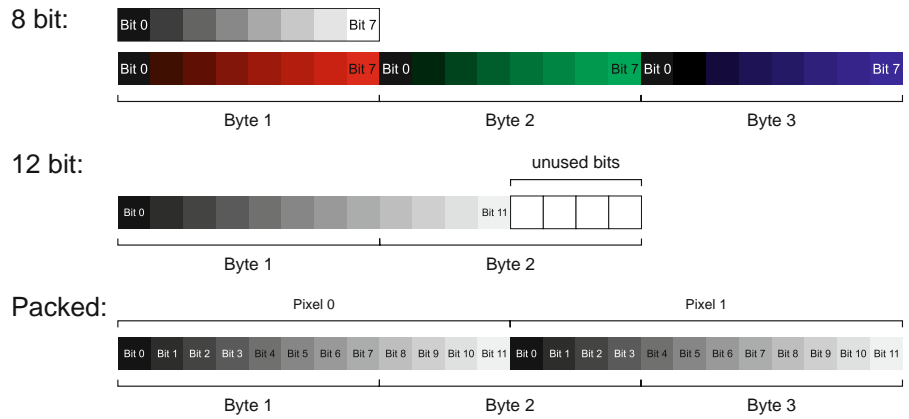

Notice

The camera must be stopped before *PixelFormat* can be set.

Name	PixelFormat
Category	ImageFormatControl
Interface	IEnumeration
Access	Read / Write
Unit	-
Values	see next tables

Camera Type	Mono8	Mono10	Mono12	Mono12p	Bayer RG8	Bayer RG10	Bayer RG12	Bayer RG12p	RGB8	BGR8
Monochrome										
VLXT-06M.I (.JP)	<input checked="" type="checkbox"/>	<input checked="" type="checkbox"/>	<input checked="" type="checkbox"/>	<input checked="" type="checkbox"/>	<input type="checkbox"/>	<input type="checkbox"/>	<input type="checkbox"/>	<input type="checkbox"/>	<input type="checkbox"/>	<input type="checkbox"/>
VLXT-17M.I	<input checked="" type="checkbox"/>	<input checked="" type="checkbox"/>	<input checked="" type="checkbox"/>	<input checked="" type="checkbox"/>	<input type="checkbox"/>	<input type="checkbox"/>	<input type="checkbox"/>	<input type="checkbox"/>	<input type="checkbox"/>	<input type="checkbox"/>
VLXT-28M.I (.JP)	<input checked="" type="checkbox"/>	<input checked="" type="checkbox"/>	<input checked="" type="checkbox"/>	<input checked="" type="checkbox"/>	<input type="checkbox"/>	<input type="checkbox"/>	<input type="checkbox"/>	<input type="checkbox"/>	<input type="checkbox"/>	<input type="checkbox"/>
VLXT-31M.I (.I) (.FO)	<input checked="" type="checkbox"/>	<input checked="" type="checkbox"/>	<input checked="" type="checkbox"/>	<input checked="" type="checkbox"/>	<input type="checkbox"/>	<input type="checkbox"/>	<input type="checkbox"/>	<input type="checkbox"/>	<input type="checkbox"/>	<input type="checkbox"/>
VLXT-50M.I (.I) (.FO)	<input checked="" type="checkbox"/>	<input checked="" type="checkbox"/>	<input checked="" type="checkbox"/>	<input checked="" type="checkbox"/>	<input type="checkbox"/>	<input type="checkbox"/>	<input type="checkbox"/>	<input type="checkbox"/>	<input type="checkbox"/>	<input type="checkbox"/>
VLXT-55M.I	<input checked="" type="checkbox"/>	<input checked="" type="checkbox"/>	<input checked="" type="checkbox"/>	<input checked="" type="checkbox"/>	<input type="checkbox"/>	<input type="checkbox"/>	<input type="checkbox"/>	<input type="checkbox"/>	<input type="checkbox"/>	<input type="checkbox"/>
VLXT-71M.I	<input checked="" type="checkbox"/>	<input checked="" type="checkbox"/>	<input checked="" type="checkbox"/>	<input checked="" type="checkbox"/>	<input type="checkbox"/>	<input type="checkbox"/>	<input type="checkbox"/>	<input type="checkbox"/>	<input type="checkbox"/>	<input type="checkbox"/>
VLXT-81M.I	<input checked="" type="checkbox"/>	<input checked="" type="checkbox"/>	<input checked="" type="checkbox"/>	<input checked="" type="checkbox"/>	<input type="checkbox"/>	<input type="checkbox"/>	<input type="checkbox"/>	<input type="checkbox"/>	<input type="checkbox"/>	<input type="checkbox"/>
VLXT-83UV.I	<input checked="" type="checkbox"/>	<input checked="" type="checkbox"/>	<input checked="" type="checkbox"/>	<input checked="" type="checkbox"/>	<input type="checkbox"/>	<input type="checkbox"/>	<input type="checkbox"/>	<input type="checkbox"/>	<input type="checkbox"/>	<input type="checkbox"/>
VLXT-90M.I (.I) (.JP) (.FO)	<input checked="" type="checkbox"/>	<input checked="" type="checkbox"/>	<input checked="" type="checkbox"/>	<input checked="" type="checkbox"/>	<input type="checkbox"/>	<input type="checkbox"/>	<input type="checkbox"/>	<input type="checkbox"/>	<input type="checkbox"/>	<input type="checkbox"/>
VLXT-123M.I (.I) (.FO)	<input checked="" type="checkbox"/>	<input checked="" type="checkbox"/>	<input checked="" type="checkbox"/>	<input checked="" type="checkbox"/>	<input type="checkbox"/>	<input type="checkbox"/>	<input type="checkbox"/>	<input type="checkbox"/>	<input type="checkbox"/>	<input type="checkbox"/>
VLXT-126M.I	<input checked="" type="checkbox"/>	<input checked="" type="checkbox"/>	<input checked="" type="checkbox"/>	<input checked="" type="checkbox"/>	<input type="checkbox"/>	<input type="checkbox"/>	<input type="checkbox"/>	<input type="checkbox"/>	<input type="checkbox"/>	<input type="checkbox"/>
VLXT-240M.I	<input checked="" type="checkbox"/>	<input checked="" type="checkbox"/>	<input checked="" type="checkbox"/>	<input checked="" type="checkbox"/>	<input type="checkbox"/>	<input type="checkbox"/>	<input type="checkbox"/>	<input type="checkbox"/>	<input type="checkbox"/>	<input type="checkbox"/>
VLXT-490M.I (.EF)	<input checked="" type="checkbox"/>	<input checked="" type="checkbox"/>	<input checked="" type="checkbox"/>	<input checked="" type="checkbox"/>	<input type="checkbox"/>	<input type="checkbox"/>	<input type="checkbox"/>	<input type="checkbox"/>	<input type="checkbox"/>	<input type="checkbox"/>
VLXN-490M.I.JP	<input checked="" type="checkbox"/>	<input checked="" type="checkbox"/>	<input checked="" type="checkbox"/>	<input checked="" type="checkbox"/>	<input type="checkbox"/>	<input type="checkbox"/>	<input type="checkbox"/>	<input type="checkbox"/>	<input type="checkbox"/>	<input type="checkbox"/>
VLXT-650M.I (.EF)	<input checked="" type="checkbox"/>	<input checked="" type="checkbox"/>	<input checked="" type="checkbox"/>	<input checked="" type="checkbox"/>	<input type="checkbox"/>	<input type="checkbox"/>	<input type="checkbox"/>	<input type="checkbox"/>	<input type="checkbox"/>	<input type="checkbox"/>
VLXN-650M.I.JP	<input checked="" type="checkbox"/>	<input checked="" type="checkbox"/>	<input checked="" type="checkbox"/>	<input checked="" type="checkbox"/>	<input type="checkbox"/>	<input type="checkbox"/>	<input type="checkbox"/>	<input type="checkbox"/>	<input type="checkbox"/>	<input type="checkbox"/>

Camera Type	Mono8	Mono10	Mono12	Mono12p	Bayer RG8	Bayer RG10	Bayer RG12	Bayer RG12p	RGB8	BGR8	YCbCr_422_8
Color											
VLXT-06C.I.JP	■	■	■	■	■	■	■	■	■	■	■
VLXT-31C.I.(.JP)	■	■	■	■	■	■	■	■	■	■	■ ^{*)}
VLXT-50C.(I) (.FO)	■	■	■	■	■	■	■	■	■	■	□
VLXT-55C.I	■	■	■	■	■	■	■	■	■	■	□
VLXT-71C.I	■	■	■	■	■	■	■	■	■	■	□
VLXT-81C.I	■	■	■	■	■	■	■	■	■	■	□
VLXT-90C.I	■	■	■	■	■	■	■	■	■	■	□
VLXT-123C.I	■	■	■	■	■	■	■	■	■	■	□
VLXT-126C.I	■	■	■	■	■	■	■	■	■	■	□
VLXT-240C.I	■	■	■	■	■	■	■	■	■	■	□
VLXT-490C.I (.EF)	■	■	■	■	■	■	■	■	■	■	□
VLXT-650C.I (.EF)	■	■	■	■	■	■	■	■	■	■	□

^{*)} .JP cameras only

Notice

At (.JP) cameras and `ImageCompressionMode = JPEG`, only the pixel formats `Mono8` and `YCbCr422_8` are available.

7.13.20 RegionMode (≥ Release 3 only)

Controls if the selected Region of interest is active and streaming.

Notice

The settings (Height, Width, OffsetX, OffsetY) of the respective region must be correct in order to be able to activate them.

Notice

With activated ImageCompression (`ImageCompression = on`) the use of Region-Mode is not possible.

Name	RegionMode	
Category	ImageFormatControl	
Interface	IEnumeration	
Access	Read / Write	
Unit	-	
Values	On	Enable the usage of the Region.
	Off	Disable the usage of the Region.

7.13.21 RegionSelector (≥ Release 3 only)

Selects the Region of interest to control. The *RegionSelector* feature allows devices that are able to extract multiple regions out of an image, to configure the features of those individual regions independently.

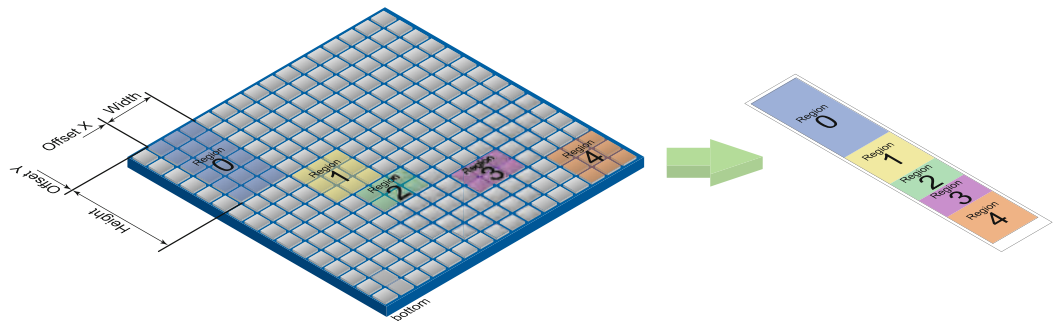

Width = Width = Width = Width = Width
(Region 0) (Region 1) (Region 2) (Region 3) (Region 4)
 (Example with 5 RO's. Maximum 8 RO's are possible.)

Name	RegionSelector	
Category	ImageFormatControl	
Interface	IEnumeration	
Access	Read / Write	
Unit	-	
Values	Region0	Selected feature will control the region 0.
	Region1	Selected feature will control the region 1.
	Region2	Selected feature will control the region 2.
	Region3	Selected feature will control the region 3.
	Region4	Selected feature will control the region 4.
	Region5	Selected feature will control the region 5.
	Region6	Selected feature will control the region 6.
	Region7	Selected feature will control the region 7.

7.13.22 ReverseX (only mono cameras / pixel formats)

Flip horizontally the image sent by the device. The Region of interest is applied before the flipping.

Notice

The camera must be stopped before this feature can be set.

Name	ReverseX
Category	ImageFormatControl
Interface	IBoolean
Access	Read / Write
Unit	-
Values	true = 1 (On) false = 0 (Off)

7.13.23 ReverseY (only monochrome cameras / pixel formats)

Flip vertically the image sent by the device. The Region of interest is applied before the flipping.

Notice

The camera must be stopped before this feature can be set.

Name	ReverseY
Category	ImageFormatControl
Interface	IBoolean
Access	Read / Write
Unit	-
Values	true = 1 (On) false = 0 (Off)

7.13.24 SensorADDigitization

The feature controls the sensors AD digitization in bits per pixels.

Notice

The camera must be stopped before this feature can be set.

Name	SensorADDigitization	
Category	ImageFormatControl	
Interface	IEnumeration	
Access	Read / Write	
Unit	-	
Values	Bpp10	The sensors AD digitization is 10 bit per pixel.
	Bpp12	The sensors AD digitization is 12 bit per pixel.
	Bpp8	The sensors AD digitization is 8 bits per pixel

7.13.25 SensorHeight

Effective height of the sensor in pixels.

Name	SensorHeight
Category	ImageFormatControl
Interface	Integer
Access	Read only
Unit	-
Values	0 ... 65535 (Increment: 1)

7.13.26 SensorName (≥ Release 2 only)

Product name of the imaging Sensor.

Name	SensorName
Category	ImageFormatControl
Interface	IString
Access	Read only
Unit	-
Values	e. g. IMX255

7.13.27 SensorPixelHeight (≥ Release 2 only)

Physical size (pitch) in the y direction of a photo sensitive pixel unit.

Name	SensorPixelHeight
Category	ImageFormatControl
Interface	IFloat
Access	Read only
Unit	um
Values	0.000000 ... 255.000000 (Increment: 1)

7.13.28 SensorPixelWidth (≥ Release 2 only)

Physical size (pitch) in the x direction of a photo sensitive pixel unit.

Name	SensorPixelWidth
Category	ImageFormatControl
Interface	IFloat
Access	Read only
Unit	um
Values	0.000000 ... 255.000000 (Increment: 1)

7.13.29 SensorWidth

Effective width of the sensor in pixels.

Name	SensorWidth
Category	ImageFormatControl
Interface	IInteger
Access	Read only
Unit	-
Values	0 ... 65535 (Increment: 1)

7.13.30 TestPattern

Selects the type of test pattern that is generated by the device as image source.

Name	TestPattern
Category	ImageFormatControl
Interface	IEnumeration
Access	Read / Write
Unit	-
Values	see table below

The following values are possible:

GreyDiagonalRamp	GreyVerticalRampHorizontalAndVertical-LineMoving
GreyDiagonalRampHorizontalAndVertical-LineMoving	GreyVerticalRampHorizontalLineMoving
GreyDiagonalRampHorizontalLineMoving	GreyVerticalRampVerticalLineMoving
GreyDiagonalRampVerticalLineMoving	HorizontalAndVerticalLineMoving
GreyHorizontalRamp	HorizontalLineMoving
GreyHorizontalRampHorizontalAndVerticalLineMoving:	Off
GreyHorizontalRampHorizontalLineMoving	PseudonoiseAndStaticRegions (.JP only) AVAILABLE: (TestPatternGeneratorSelector = ImageProcessor).
GreyHorizontalRampVerticalLineMoving	VerticalLineMoving
GreyVerticalRamp	

7.13.31 TestPatternGeneratorSelector

Selects which test pattern generator is controlled by the *TestPattern* feature.

Name	TestPatternGeneratorSelector	
Category	ImageFormatControl	
Interface	IEnumeration	
Access	Read / Write	
Unit	-	
Values	ImageProcessor	TestPattern feature will control the image processor.
	Sensor Processor	TestPattern feature will control the sensor processor.

7.13.32 Width

Width of the image provided by the device (in pixels).

Notice

(≥ Release 3 only)

When using Multi-ROI, all ROI's must have the same width.

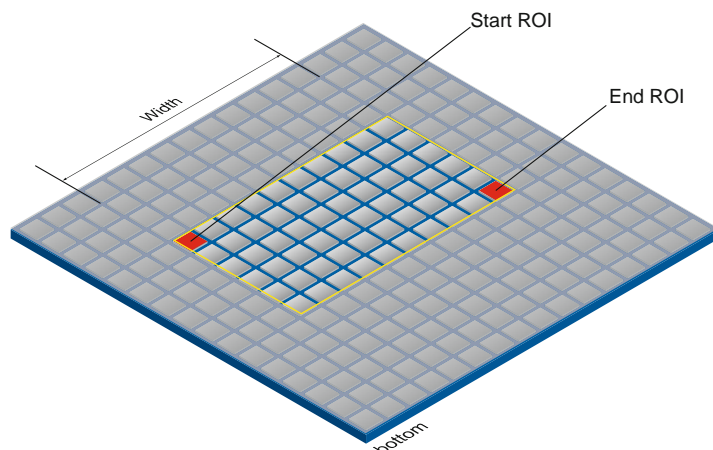

Name	Width
Category	ImageFormatControl
Interface	IInteger
Access	Read / Write
Unit	-
Values	see table below

Camera Type**Monochrome**

VLXT-06M.I (.JP)	64 ... 800 (Increment: 32)
VLXT-17M.I	64 ... 1600 (Increment: 32)
VLXT-28M.I (.JP)	64 ... 1920 (Increment: 32)
VLXT-31M.I (.FO)	32 ... 2048 (Increment: 16)
VLXT-50M.I (.FO)	32 ... 2448 (Increment: 16)
VLXT-55M.I	64 ... 2464 (Increment: 32)
VLXT-71M.I	64 ... 3200 (Increment: 32)
VLXT-81M.I	64 ... 2848 (Increment: 32)
VLXT-83UV.I	64 ... 2848 (Increment: 32)
VLXT-90M.I (.JP) (.FO)	64 ... 4096 (Increment: 32)
VLXT-123M.I (.FO)	64 ... 4096 (Increment: 32)
VLXT-126M.I	64 ... 4096 (Increment: 32)
VLXT-240M.I	64 ... 5312 (Increment: 32)
VLXT-490M.I (.EF)	64 ... 7008 (Increment: 32)
VLXN-490M.I.JP	64 ... 7008 (Increment: 32)
VLXT-650M.I (.EF)	64 ... 9344 (Increment: 32)
VLXN-650M.I.JP	64 ... 9344 (Increment: 32)

Color

VLXT-06C.I.JP	64 ... 800 (Increment: 32)
VLXT-31C.I (.JP)	32 ... 2048 (Increment: 16)
VLXT-50C.I (.FO)	32 ... 2448 (Increment: 16)
VLXT-55C.I	64 ... 2464 (Increment: 32)
VLXT-71C.I	64 ... 3200 (Increment: 32)
VLXT-81C.I	64 ... 2848 (Increment: 32)
VLXT-90C.I	32* 64 ... 4096 (Increment: 16* 32)
VLXT-123C.I	32* 64 ... 4096 (Increment: 16* 32)
VLXT-126C.I	32 ... 4096 (Increment: 32)
VLXT-240C.I	64 ... 5312 (Increment: 32)
VLXT-490C.I (.EF)	32 ... 7008 (Increment: 16)
VLXT-650C.I (.EF)	32 ... 9344 (Increment: 16)

*) ≥ Release 2

7.13.33 WidthMax

Maximum width of the image (in pixels). The dimension is calculated after horizontal binning, decimation or any other function changing the horizontal dimension of the image.

Name	WidthMax
Category	ImageFormatControl
Interface	Integer
Access	Read only
Unit	-
Values	Resolution of the sensor in X-direction.

Camera Type

Monochrome

VLXT-06M.I (.JP)	800
VLXT-17M.I	1600
VLXT-28M.I (.JP)	1920
VLXT-31M(.I) (.FO)	2048
VLXT-50M(.I) (.FO)	2448
VLXT-55M.I	2464
VLXT-71M.I	3200
VLXT-81M.I	2848
VLXT-83UV.I	2848
VLXT-90M(.I) (.JP) (.FO)	4096
VLXT-123M(.I) (.FO)	4096
VLXT-126M.I	4096
VLXT-240M.I	5312
VLXT-490M.I (.EF)	7008
VLXN-490M.I.JP	7008
VLXT-650M.I (.EF)	9344
VLXN-650M.I.JP	9344

Color

VLXT-06C.I.JP	800
VLXT-31C.I (.JP)	2048
VLXT-50C(.I) (.FO)	2448
VLXT-55C.I	2464
VLXT-71C.I	3200
VLXT-81C.I	2848
VLXT-90C.I	4096
VLXT-123C.I	4096
VLXT-126C.I	4096
VLXT-240C.I	5312
VLXT-490C.I (.EF)	7008
VLXT-650C.I (.EF)	9344

7.14 Category: ImageProcessingControl (≥ Release 3 only)

Category that contains the Baumer image processing features.

General Information - Shading Correction

Uneven lighting can result in some areas of the image being darker than others. Shading Correction provides the option to compensate for brightness irregularities in the image.

How to set up Shading Correction with Baumer Camera Explorer

1. Start the *Camera Explorer*. Connect to the camera. Select the profile *Gen/Cam Guru* if necessary.
2. Open the category *Image Processing Control*.
3. Configure the lighting situation as it will be for the planned application.

4. Place an homogeneous white or grey template in the camera's field of view.

Clear shadings can be seen in the corners.



5. Activate the Shading Correction by checking the *ShadingEnable* box.
6. Start the Shading Correction by executing the command *ShadingCalibration-Start*.

Notice

The execution of the shading correction can take 5 - 15 s depending on the sensor size!

7. Now you will see a corrected image without shadings in the corners.

If necessary, change the lighting situation and run the *ShadingCalibration-Start* command again if not all shading should be corrected.

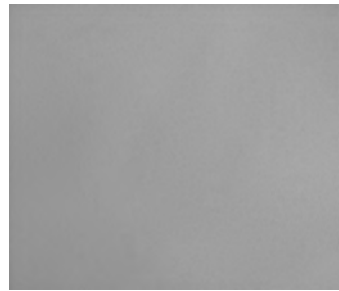

Notice

To completely delete the correction data of a Shading Correction, a *DeviceResetToDeliveryState* must be executed.

[see chapter „7.9.15 DeviceResetToDeliveryState“ on page 96](#)

7.14.1 ShadingCalibrationStart

Starts the Shading Calibration.

Notice

To execute the Shading Correction: `SequencerMode = Off`.

Name	ShadingCalibrationStart
Category	ImageProcessingControl
Interface	ICommand
Access	Write only
Unit	-
Values	-

7.14.2 ShadingEnable

Enables the Shading Correction.

Notice

To activate *ShadingEnable*, no Multi-ROI must be defined.

[see chapter „7.13.20 RegionMode \(≥ Release 3 only\)“ on page 153](#)

Name	ShadingEnable
Category	ImageProcessingControl
Interface	IBoolean
Access	Read / Write
Unit	-
Values	true = 1 (On) false = 0 (Off)

7.14.3 SharpeningFactor

This feature contains the factor for Sharpening.

Name	SharpeningFactor
Category	ImageProcessingControl
Interface	IInteger
Access	Read / Write
Unit	-
Values	1 ... 5 (Increment: 1)

7.14.4 SharpeningMode

This feature selects the Sharpening Mode.

Name	SharpeningMode	
Category	ImageProcessingControl	
Interface	IEnumeration	
Access	Read / Write	
Unit	-	
Values	ActiveNoiseReduction	Sharpening is enabled in active noise reduction mode.
	AdaptiveSharpening	Sharpening is enabled in adaptive sharpening mode.
	GlobalSharpening	Sharpening is enabled in global sharpening mode.
	Off	Sharpening is disabled.

7.14.5 SharpeningSensitivityThreshold

This feature holds the value of the Sharpening Sensitivity Threshold.

Name	SharpeningSensitivityThreshold
Category	ImageProcessingControl
Interface	IInteger
Access	Read / Write
Unit	-
Values	1 ... 5 (Increment: 1)

7.15 Category: LUTControl

Features in this chapter describe the Look-up table (LUT) related features. For LUT related features, certain values are stored in the camera. This includes the coordinates of defective pixels so that they can be corrected.

General information (Pixel Correction)

There is a certain probability of abnormal pixels – so-called defect pixels – occurring within sensors from all manufacturers. The charge quantity of these pixels is not linearly dependent on the exposure time.

The occurrence of these defect pixels is unavoidable and intrinsic to the manufacturing and aging process of the sensors.

The operation of the camera is not affected by these pixels. They only appear as brighter (warm pixel) or darker (cold pixel) spots on the recorded image.

Distinction of "hot" and "cold" pixels within the recorded image.

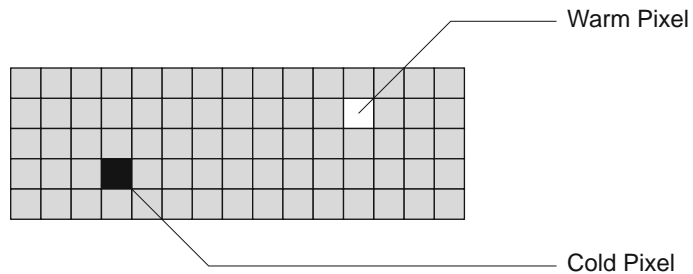

Charge quantity of "hot" and "cold" pixels compared with "normal" pixels:

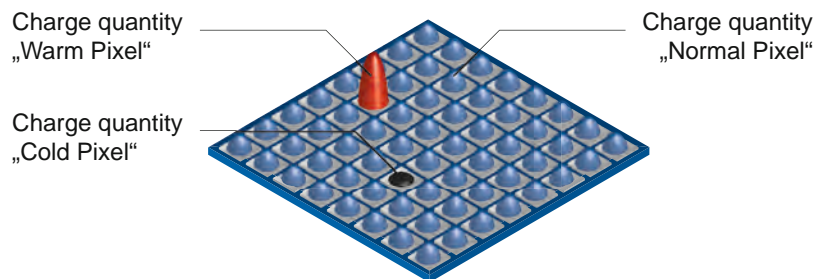

Correction Algorithm (Pixel Correction)

On Baumer cameras the problem of defect pixels is solved as follows:

- Possible defect pixels are identified during the production process of the camera.
- The coordinates of these pixels are stored in the factory settings of the camera.
- Once the sensor readout is completed, correction takes place:
 - Before any other processing, the values of the neighboring pixels on the left and the right side of the defect pixels, will be read out. (within the same bayer phase for color)
 - Then the average value of these 2 pixels is determined to correct the first defect pixel
 - Finally, the value of the second defect pixel is corrected by using the previously corrected pixel and the pixel of the other side of the defect pixel.

Examples for the correction of defect pixels

The diagram illustrates the correction process for different numbers of defect pixels in a 1D array. A legend indicates: cyan for defect pixels, red for corrected pixels, and green for original pixels.

1 defect pixel: The initial state is [7, 12, 99, 8, 13, 8]. The defect pixel (99) is corrected to 10 in Step 1, resulting in [7, 12, 10, 8, 13, 8].

2 defect pixels:

- Example 1:** Initial state [7, 12, 99, 99, 13, 8]. Step 1 corrects the first 99 to 10. Step 2 corrects the second 99 to 7, resulting in [7, 12, 7, 10, 13, 8].
- Example 2:** Initial state [7, 12, 99, 8, 99, 8, 5]. Step 1 corrects the first 99 to 7. Step 2 corrects the second 99 to 6, resulting in [7, 12, 7, 8, 6, 8, 5].

3 defect pixels:

- Example 1:** Initial state [7, 12, 99, 99, 99, 8, 5]. Step 1 corrects the first 99 to 7. Step 2 corrects the second 99 to 10. Step 3 corrects the third 99 to 6, resulting in [7, 12, 7, 10, 6, 8, 5].
- Example 2:** Initial state [7, 12, 99, 8, 99, 8, 68, 18, 15]. Step 1 corrects the first 99 to 7. Step 2 corrects the second 99 to 7. Step 3 corrects the third 99 to 11, resulting in [7, 12, 7, 8, 7, 8, 11, 18, 15].

General Information (Defect Pixel List)

As stated previously, this list is determined during the camera's production and stored in the factory settings.

Additional hot or cold pixels can develop during the lifecycle of a camera. If this happens, Baumer gives you the option to add their coordinates to the defect pixel list.

You can determine the coordinates*) of the affected pixels and add them to the list. Once the defect pixel list is stored in a user set, pixel correction is carried out for all coordinates on the defect pixel list.

Notice

There are defect pixels, which occur only under certain environmental parameters. These include temperatures or exposure settings.

Complete defect pixels that occur in your application.

*) Position in relation to full frame format (raw data format)

Add Defect Pixel to Defect Pixel List with Baumer Camera Explorer

Notice

The addition of defect pixels must be done in FullFrame (without *Binning*, without *Width / Height / OffsetX / OffsetY*), in raw data format and without activated color calculation.

1. Start the *Camera Explorer*. Connect to the camera. Select the profile *GenICam Guru* if necessary..
2. Open the category *LUT Control*.
3. Locate an empty *Defect Pixel List Index*.
Defect Pixel List Entry PosX = 0
Defect Pixel List Entry PosY = 0
Avoid using existing coordinates!
4. Determine the coordinates of the defect pixel. Keep the mouse pointer over the defect pixel. The coordinates of the defect pixel is displayed in the status bar.
For simplification, you can enlarge the image.
5. Enter the determined coordinates for X (*Defect Pixel List Entry PosX*) and Y (*Defect Pixel List Entry PosY*).
6. Activate the registered *Defect Pixel List Index* (*Defect Pixel List Entry Active = True*).
7. Stop the camera and start them again to take over the updated coordinates.

7.15.1 DefectPixelCorrection

Enable the correction of defect pixels.

Name	DefectPixelCorrection
Category	LUTControl
Interface	IBoolean
Access	Read / Write
Unit	-
Values	true = 1 (On) false = 0 (Off)

7.15.2 DefectPixelListEntryActive

Determines if the pixel correction is active for the selected entry.

Name	DefectPixelListEntryActive
Category	LUTControl
Interface	IBoolean
Access	Read / Write
Unit	-
Values	true = 1 (On) false = 0 (Off)

7.15.3 DefectPixelListEntryPosX

X position of the defect pixel.

Name	DefectPixelListEntryPosX
Category	LUTControl
Interface	Integer
Access	Read / Write
Unit	-
Values	0 ... Resolution of the sensor in X-direction. (Increment: 1)

7.15.4 DefectPixelListEntryPosY

Y position of the defect pixel.

Name	DefectPixelListEntryPosY
Category	LUTControl
Interface	Integer
Access	Read / Write
Unit	-
Values	0 ... Resolution of the sensor in Y-direction. (Increment: 1)

7.15.5 DefectPixelListIndex

Index to the pixel correction list.

Name	DefectPixelListIndex
Category	LUTControl
Interface	Integer
Access	Read / Write
Unit	-
Values	0 ... 511 (Increment: 1)

7.15.6 DefectPixelListSelector

Selects which Defect Pixel List to control.

Name	DefectPixelListSelector
Category	LUTControl
Interface	Enumeration
Access	Read / Write
Unit	-
Values	Pixel Selects Defect Pixel List for defect pixels.

7.15.7 LUTContent

Describes the content of the selected LUT.

Name	LUTContent	
Category	LUTControl	
Interface	IEnumeration	
Access	Read / Write	
Unit	-	
Values	Gamma	The content of the selected LUT is defined by the value of the feature Gamma.
	UserdefinedLUT	The content of the selected LUT is user defined.

7.15.8 LUTEnable

Activates the selected LUT.

Name	LUTEnable	
Category	LUTControl	
Interface	IBoolean	
Access	Read / Write	
Unit	-	
Values	true = 1 (On)	
	false = 0 (Off)	

7.15.9 LUTIndex

Control the index (offset) of the coefficient to access in the selected LUT.

Name	LUTIndex	
Category	LUTControl	
Interface	IInteger	
Access	Read / Write	
Unit	-	
Values	0 ... 4095 (Increment: 1)	

7.15.10 LUTSelector

Selects which LUT to control.

Name	LUTContent	
Category	LUTControl	
Interface	IEnumeration	
Access	Read / Write	
Unit	-	
Values	Luminance	Selects the Luminance LUT.

7.15.11 LUTValue

Returns the Value at entry LUTIndex of the LUT selected by LUTSelector.

Name	LUTValue
Category	LUTControl
Interface	Integer
Access	Read / Write
Unit	-
Values	0 ... 4095 (Increment: 1)

7.16 Category: MemoryManagement

Category to support the cameras buffer management in memory.

Notice

Memory management is not used when:

`AcquisitionMode = Continuous`

and

`TriggerMode = Off.`

Memory management is used when:

`AcquisitionMode = MultiFrame`

or

`TriggerMode = On`

or

`SequencerMode = On`

7.16.1 MemoryFreeBlocks

Count of free memory blocks for configuration. It depends on partial scan features, pixel-format and selected acquisition format.

Name	MemoryFreeBlocks
Category	MemoryManagement
Interface	Integer
Access	Read only
Unit	-
Values	-2147483648 ... 2147483647 (Increment: 1)

7.16.2 MemoryMaxBlocks

Maximum count of available memory blocks. It depends on partial scan features, pixel format and selected acquisition format.

Name	MemoryMaxBlocks
Category	MemoryManagement
Interface	IInteger
Access	Read only
Unit	-
Values	0 ... 4294967295 (Increment: 1)

7.17 Category: OpticControl (≥ Release 3 / .EF only)

Category for the data Optic Control features.

7.17.1 Aperture (.EF only)

Sets the aperture (also called iris, f-number, f-stop or f/#) of the lens. The lower the f/# the more light goes through the lens (the "faster" the lens) and the smaller the depth of field.

Name	Aperture
Category	OpticControl
Interface	IFloat
Access	Read / Write
Unit	-
Values	e.g. 4.362031 ... 28.100035 (Increment:0.50) value range depending on lens

7.17.2 ApertureInitialize (.EF only)

Initializes the aperture and makes it ready for use. The aperture position after initialization is implementation dependent. This feature is only implemented if an additional initialization is required after OpticControllerInitialize.

Name	ApertureInitialize
Category	OpticControl
Interface	ICommand
Access	Write only
Unit	-
Values	-

7.17.3 ApertureStatus (.EF only)

Reads the status of the Aperture feature.

Name	ApertureStatus	
Category	OpticControl	
Interface	IEnumeration	
Access	Read only	
Unit	-	
Values	Busy	The aperture executes a feature access/command.
	Error	The aperture encountered an error.
	Not Connected	The aperture is physically not connected.
	Not Initialized	The aperture is not initialized.
	Not Supported	The aperture is physically connected but not supported.
	Ready	The aperture is ready to use.

7.17.4 ApertureStepper (.EF only)

ApertureStepper controls the stepper value of the Aperture. The minimum value is the maximum aperture.

Name	ApertureStepper	
Category	OpticControl	
Interface	IInteger	
Access	Read / Write	
Unit	-	
Values	e.g. 42 ... 85 (Increment: 1) value range depending on lens	

7.17.5 FocalLength

Focal length in millimeters.

Name	FocalLength	
Category	OpticControl	
Interface	IFloat	
Access	Read only	
Unit	mm	
Values	e.g. 0 ... 4,294,967,295,000000 (Increment:1.00) value range depending on lens	

7.17.6 FocalLengthInitialize (.EF only)

Initializes the focal length and makes it ready for use. The focal length position after initialization is implementation dependent. This feature is only implemented if an additional initialization is required after OpticControllerInitialize.

Name	FocalLengthInitialize
Category	OpticControl
Interface	ICommand
Access	Write only
Unit	-
Values	-

7.17.7 FocalLengthStatus (.EF only)

Reads the status of the FocalLength feature.

Name	FocalLengthStatus	
Category	OpticControl	
Interface	IEnumeration	
Access	Read only	
Unit	-	
Values	Busy	The focal length executes a feature access/command.
	Error	The focal length encountered an error.
	Not Connected	The focal length is physically not connected.
	Not Initialized	The focal length is not initialized.
	Not Supported	The focal length is physically connected but not supported.
	Ready	The focal length is ready to use.

7.17.8 FocusInitialize (.EF only)

Initializes the focus and makes it ready for use. The focus position after initialization is implementation dependent. This feature is only implemented if an additional initialization is required after OpticControllerInitialize.

Name	FocusInitialize
Category	OpticControl
Interface	ICommand
Access	Write only
Unit	-
Values	-

7.17.9 FocusStatus (.EF only)

Reads the status of the Focus feature.

Name	FocalLengthStatus	
Category	OpticControl	
Interface	IEnumeration	
Access	Read only	
Unit	-	
Values	Busy	The focus executes a feature access/command.
	Error	The focus encountered an error.
	Not Connected	The focus is physically not connected.
	Not Initialized	The focus is not initialized.
	Not Supported	The focus is physically connected but not supported.
	Ready	The focus is ready to use.

7.17.10 FocusStepper

FocusStepper controls the stepper value of the Focus, e.g. ObjectSensorDistance or FocalPower. 0 is the closest focus.

Notice

The cameras are frequently installed in industrial environments. These environments often include devices that generate electromagnetic interference (EMI) and they are prone to electrostatic discharge (ESD). Excessive EMI and ESD can change the set focus. Update this value if necessary.

Name	FocusStepper
Category	OpticControl
Interface	IInteger
Access	Read / Write
Unit	-
Values	e.g. 0 ... 46000 (Increment: 1) value range depending on lens

7.17.11 OpticControllerDisconnect

Prepares the optic controller for removal.

Name	OpticControllerDisconnect
Category	OpticControl
Interface	ICommand
Access	Write only
Unit	-
Values	-

7.17.12 OpticControllerFamilyName (except .EF)

Name of the device family of the optic controller.

Name	OpticControllerFamilyName
Category	OpticControl
Interface	IString
Access	Read only
Unit	-
Values	value range depending on lens

7.17.13 OpticControllerFirmwareVersion

Version of the firmware in the optic controller.

Notice

This feature is always available when a lens is detected, even if the lens has an unsupported firmware version.

Name	OpticControllerFirmwareVersion
Category	OpticControl
Interface	IInteger
Access	Read only
Unit	-
Values	0 ... 4294967295 (Increment: 1)

7.17.14 OpticControllerInitialize

Initializes the optic controller and makes it ready for use.

Notice

For lens detection, you must execute this command after connecting the lens. After detecting a supported lens, the corresponding features are available.

Name	OpticControllerInitialize
Category	OpticControl
Interface	ICommand
Access	Write only
Unit	-
Values	-

7.17.15 OpticControllerModelName (except .EF)

Model name of the optic controller.

Name	OpticControllerModelName
Category	OpticControl
Interface	IString
Access	Read only
Unit	-
Values	e.g. Caspian C-C-39N0-160R33

7.17.16 OpticControllerSelector

Selects which optic controller to configure.

Name	OpticControllerSelector
Category	OpticControl
Interface	IEnumeration
Access	Read / Write
Unit	-
Values	OpticController0 Optic Controller 0.

7.17.17 OpticControllerSerialNumber (except .EF)

Serial number of the optic controller.

Name	OpticControllerSerialNumber
Category	OpticControl
Interface	IString
Access	Read only
Unit	-
Values	e.g. 1731170157

7.17.18 OpticControllerStatus

Reads the state of the optic controller.

Name	OpticControllerStatus	
Category	OpticControl	
Interface	IEnumeration	
Access	Read only	
Unit	-	
Values	Busy	The optic controller executes a feature access/command.
	Error	The optic controller encountered an error.
	Not Connected	The optic controller is physically not connected.
	Not Initialized	The optic controller is not initialized.
	Not Supported:	The optic controller is physically connected but not supported.
	Ready	The optic controller is ready to use.

7.17.19 OpticControllerTemperature (except .EF)

Optical controller temperature in degrees Celsius (C).

Name	OpticControllerTemperature
Category	OpticControl
Interface	IFloat
Access	Read only
Unit	°C
Values	-127.0 ... 127.0

7.17.20 OpticControllerThermalCompensation (except .EF)

The focus of the lens may change as the operating temperature increases. With this feature you enable or disable the thermal compensation of the optic controller.

Notice

Function available for Varioptic with firmware \geq v38.

Name	OpticControllerThermalCompensation
Category	OpticControl
Interface	IBoolean
Access	Read / Write
Unit	-
Values	true = 1 (On)
	false = 0 (Off)

7.17.21 OpticControllerVendorName

Name of the manufacturer of the optic controller.

Name	OpticControllerVendorName
Category	OpticControl
Interface	IString
Access	Read only
Unit	-
Values	e.g. Corning Varioptic / Canon EF compatible

7.17.22 OpticControllerVersion (except .EF)

Version of the optic controller.

Name	OpticControllerVersion
Category	OpticControl
Interface	IString
Access	Read only
Unit	-
Values	depending on lens

7.18 Category: SequencerControl

Category for the Sequencer Control features.

The Sequencer enables the possibility of image series recording including automated re-parameterization of the camera based on different events and signals. Therefore the desired camera settings for each step are stored in so called sequencer sets.

Stringing together a number of these sequencer sets results in a sequence. The connection of sequences is done by using different paths. Alongside the camera features the path related features are also part of a sequencer set.

Sequencer sets

Sequencer sets combine camera features – comparable with a user set – and sequencer (set and path) related parameters.

Settings for several camera features such as:

- Exposure time
- Gain
- Region of Interest (OffsetX / OffsetY / Width / Height)
- User output
- Counter

can be controlled by the sequencer and thus stored to a sequencer set as well as information for the set switch-over via four different paths.

Notice

With the Feature *SequencerFeatureSelector* you can see all available features of a Sequencer Set.

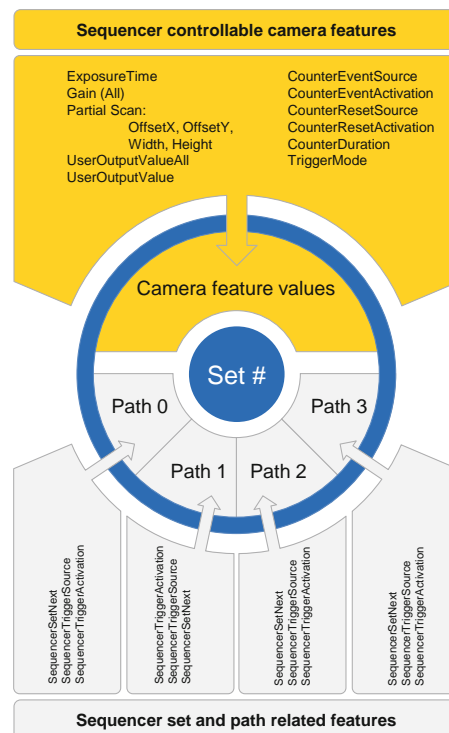

Each path involves:

- the destination for the set switch-over that is mapped by the SequencerSetNext feature
- the signal, whose change of state is used for triggering the set switch-over and that is mapped as SequencerTriggerSource
- the change of state triggering the set switch-over and that is mapped as 'Sequencer-TriggerActivation'

As with user sets the camera's current settings are overwritten once a sequencer set is loaded and the sequencer is activated.

Sequencer configuration

In order to avoid overwriting current camera settings while configuring a sequencer, the camera needs to be set to the sequencer configuration mode.

Once the camera is set to the sequencer configuration mode, the individual sequencer sets can be selected via the SequencerSetSelector, configured and saved by executing SequencerSetSave. Sequencer Sets can also be loaded and modified.

Starting the configured sequence requires to switch the sequencer configuration mode off and to enable the sequencer mode.

7.18.1 SequencerConfigurationMode

Controls if the sequencer configuration mode is active.

Name	SequencerConfigurationMode	
Category	SequencerControl	
Interface	IEnumeration	
Access	Read / Write	
Unit	-	
Values	On	Enables the sequencer configuration mode.
	Off	Disables the sequencer configuration mode.

7.18.2 SequencerFeatureEnable

Enables the selected feature and make it active in all the sequencer sets.

Name	SequencerFeatureEnable	
Category	SequencerControl	
Interface	IBoolean	
Access	Read only	
Unit	-	
Values	true = 1 (On)	
	false = 0 (Off)	

7.18.3 SequencerFeatureSelector

Selects the camera features that are controlled by the sequencer.

Name	SequencerFeatureSelector	
Category	SequencerControl	
Interface	IEnumeration	
Access	Read / Write	
Unit	-	
Values	CounterDuration	Sets the duration (or number of events) before the CounterEnd event is generated.
	CounterEventActivation	Selects the Activation mode Event Source signal.
	CounterEventSource	Select the events that will be the source to increment the Counter.
	CounterResetActivation	Selects the Activation mode of the Counter Reset Source signal.
	CounterResetSource	Selects the signals that will be the source to reset the Counter.
	ExposureMode	Sets the operation mode of the Exposure (or shutter).
	ExposureTime	Returns the exposure time used to capture the image.
	Gain	Controls the selected gain as an absolute physical value.
	Height	Height of the image provided by the device (in pixels).
	OffsetX	Horizontal offset from the origin to the region of interest (in pixels).
	OffsetY	Vertical offset from the origin to the region of interest (in pixels).
	TriggerMode	Controls if the selected trigger is active.
	UserOutputValue	Sets the value of the bit selected by UserOutputSelector.
	UserOutputValueAll	Sets the value of all the bits of the User Output register.
	Width	Width of the image provided by the device (in pixels).

7.18.4 SequencerMode

Controls if the sequencer mechanism is active.

Notice

To activate the feature, the following requirements must be accomplished:

```
BalanceWhiteAuto = off  
SequencerConfigurationMode = off  
HDREnable = false
```

≥ Release 3 only

When the sequencer is active (`SequencerMode = on`), the sequencer sets can be loaded. Therefore the features *SequencerSetSelector* and *SequencerSetLoad* are available. After executing the *SequencerSetLoad* command, the selected sequencer set settings can be read as in sequencer configuration mode.

Name	SequencerMode
Category	SequencerControl
Interface	IEnumeration
Access	Read / Write
Unit	-
Values	On Enables the sequencer.
	Off Disables the sequencer.

7.18.5 SequencerPathSelector

Selects the path that contains the settings coming afterward.

Name	SequencerPathSelector
Category	SequencerControl
Interface	IInteger
Access	Read / Write
Unit	-
Values	0 ... 3 (Increment: 1)

7.18.6 SequencerSetActive

Contains the currently active sequencer set.

Name	SequencerSetActive
Category	SequencerControl
Interface	IInteger
Access	Read / Write
Unit	-
Values	0 ... 127 (Increment: 1)

7.18.7 SequencerSetLoad

Loads the sequencer set selected by SequencerSetSelector in the device.

Name	SequencerSetLoad
Category	SequencerControl
Interface	ICommand
Access	Write only
Unit	-
Values	-

7.18.8 SequencerSetNext

Specifies the next sequencer set.

Name	SequencerSetNext
Category	SequencerControl
Interface	IInteger
Access	Read / Write
Unit	-
Values	0 ... 127 (Increment: 1)

7.18.9 SequencerSetSave

Saves the current device state to the sequencer set selected by the SequencerSetSelector.

Name	SequencerSetSave
Category	SequencerControl
Interface	ICommand
Access	Write only
Unit	-
Values	-

7.18.10 SequencerSetSelector

Selects the sequencer set to which further feature settings applies.

Name	SequencerSetSelector
Category	SequencerControl
Interface	IInteger
Access	Read / Write
Unit	-
Values	0 ... 127 (Increment: 1)

7.18.11 SequencerSetStart

Sets the initial/start sequencer set, which is the first set used within a sequencer.

Name	SequencerSetStart
Category	SequencerControl
Interface	Integer
Access	Read / Write
Unit	-
Values	0 ... 127 (Increment: 1)

7.18.12 SequencerTriggerActivation

Defines the signals edge that triggers the sequencer.

Name	SequencerTriggerActivation	
Category	SequencerControl	
Interface	IEnumeration	
Access	Read / Write	
Unit	-	
Values	AnyEdge	Specifies that the trigger is considered valid on the falling or rising edge of the source signal.
	FallingEdge	Specifies that the trigger is considered valid on the falling edge of the source signal.
	LevelHigh (≥ Rel. 2)	Specifies that the trigger is considered valid as long as the level of the source signal is high.
	LevelLow (≥ Rel. 2)	Specifies that the trigger is considered valid as long as the level of the source signal is low.
	RisingEdge	Specifies that the trigger is considered valid on the rising edge of the source signal.

7.18.13 SequencerTriggerSource

Specifies the internal signal or physical input line to use as the sequencer trigger source.

Name	SequencerTriggerSource	
Category	SequencerControl	
Interface	IEnumeration	
Access	Read / Write	
Unit	-	
Values	Counter1End	Starts with the reception of the Counter End.
	Counter2End	Starts with the reception of the Counter End.
	ExposureActive	Starts with the reception of the Exposure Active.
	Line0	Specifies Line 0 as external trigger source.
	Line1 (≥ Rel. 2)	Specifies Line 1 as external trigger source.
	Off	Disables the sequencer trigger.
	ReadOutActive	Starts with the reception of the Read Out Active.
	Timer1End	Starts with the reception of the Timer End.

7.19 Category: TransferControl

Category for the data Transfer Control features.

7.19.1 TransferStart

Starts the streaming of data blocks out of the device.

If the TransferStart feature is not writable (locked), the application should not start the transfer and should avoid using the feature until it becomes writable again.

Name	TransferStart
Category	TansferControl
Interface	ICommand
Access	Write only
Unit	-
Values	-

7.19.2 TransferStatus

Reads the status of the Transfer module signal selected by *TransferStatusSelector*.

Name	TransferStatus
Category	TansferControl
Interface	IBoolean
Access	Read only
Unit	-
Values	true = 1 (On) false = 0 (Off)

7.19.3 TransferStatusSelector

Selects which status of the transfer module to read.

Name	TransferStatusSelector
Category	TansferControl
Interface	IEnumeration
Access	Read / Write
Unit	-
Values	Stopped Data block transmission is stopped. Streaming Data blocks are transmitted when enough data is available.

7.19.4 TransferStop

Stops the streaming of data Block(s). The current block transmission will be completed.

Name	TransferStop
Category	TansferControl
Interface	ICommand
Access	Write only
Unit	-
Values	-

7.20 Category: TransportLayerControl

This chapter provides the Transport Layer control features.

7.20.1 EnergyEfficientEthernetEnable (≥ Release 2 only)

Controls whether the Energy Efficient / Green Ethernet mode (802.3az) in the PHY is activated or not.

Notice

A device reboot is needed for changes to take effect.

Notice

By deactivating *EnergyEfficientEthernetEnable* (`EnergyEfficientEthernetEnable = false`), higher accuracy may be achieved when using PTP (`PtpEnable = true`). Furthermore a reduction of the time until the system settles down (`PtpServoStatus = Locked`) can be achieved.

Name	EnergyEfficientEthernetEnable
Category	TansportLayerControl
Interface	IBoolean
Access	Read / Write
Unit	-
Values	true = 1 (On) false = 0 (Off)

7.20.2 Category: GigE Vision

Category that contains the features pertaining to the GigE Vision transport layer of the device.

7.20.2.1 GVSPConfigurationBlockID64Bit

Enables the 64 bit block ID length.

Name	GVSPConfigurationBlockID64Bit
Category	GigE Vision
Interface	IBoolean
Access	Read only
Unit	-
Values	true = 1 (On) false = 0 (Off)

7.20.2.2 GevCCP

Controls the device access privilege of an application.

Name	GevCCP
Category	GigE Vision
Interface	IEnumeration
Access	Read / Write
Unit	-
Values	OpenAccess Open Access. ExclusiveAccess Exclusive Access. ControlAccess Control Access.

7.20.2.3 GevCurrentDefaultGateway

Reports the default gateway IP address to be used on the given logical link.

Name	GevCurrentDefaultGateway
Category	GigE Vision
Interface	IInteger
Access	Read only
Unit	-
Values	IP address

7.20.2.4 GevCurrentIPAddress

Reports the IP address for the given logical link.

Name	GevCurrentIPAddress
Category	GigEVision
Interface	Integer
Access	Read only
Unit	-
Values	IP address

7.20.2.5 GevCurrentIPConfigurationDHCP

Controls whether the DHCP IP configuration scheme is activated on the given logical link.

Name	GevCurrentIPConfigurationDHCP
Category	GigEVision
Interface	Boolean
Access	Read / Write
Unit	-
Values	true = 1 (On) false = 0 (Off)

7.20.2.6 GevCurrentIPConfigurationLLA

Controls whether the Link Local Address IP configuration scheme is activated on the given logical link.

Name	GevCurrentIPConfigurationLLA
Category	GigEVision
Interface	Boolean
Access	Read only
Unit	-
Values	true = 1 (On) false = 0 (Off)

7.20.2.7 GevCurrentIPConfigurationPersistentIP

Controls whether the PersistentIP configuration scheme is activated on the given logical link.

Name	GevCurrentIPConfigurationPersistentIP
Category	GigEVision
Interface	Boolean
Access	Read / Write
Unit	-
Values	true = 1 (On) false = 0 (Off)

7.20.2.8 **GevCurrentSubnetMask**

Reports the subnet mask of the given logical link.

Name	GevCurrentSubnetMask
Category	GigEVision
Interface	IInteger
Access	Read only
Unit	-
Values	IP address

7.20.2.9 **GevFirstURL**

Indicates the first URL to the GenICam XML device description file. The First URL is used as the first choice by the application to retrieve the GenICam XML device description file.

Name	GevFirstURL
Category	GigEVision
Interface	IString
Access	Read only
Unit	-
Values	URL

7.20.2.10 **GevGVCPExtendedStatusCodes**

Enables the generation of extended status codes.

Name	GevGVCPExtendedStatusCodes
Category	GigEVision
Interface	IBoolean
Access	Read / Write
Unit	-
Values	true = 1 (On) false = 0 (Off)

7.20.2.11 **GevGVCPExtendedStatusCodesSelector**

Selects the GigE Vision version to control extended status codes for.

Name	GevGVCPExtendedStatusCodesSelector
Category	GigEVision
Interface	IEnumeration
Access	Read / Write
Unit	-
Values	Version1_1 Version1_1. Version2_0 Version2_0.

7.20.2.12 **GevGVCPendingAck**

Enables the generation of PENDING_ACK.

Name	GevGVCPendingAck
Category	GigEVision
Interface	IBoolean
Access	Read / Write
Unit	-
Values	true = 1 (On) false = 0 (Off)

7.20.2.13 **GevIPConfigurationStatus**

Reports the current IP configuration status.

Name	GevGVCPExtendedStatusCodesSelector
Category	GigEVision
Interface	IEnumeration
Access	Read only
Unit	-
Values	None None. PersistentIP Persistent IP. DHCP DHCP. LLA LLA. ForceIP Force IP.

7.20.2.14 **GevInterfaceSelector**

Selects which logical link to control.

Name	GevInterfaceSelector
Category	GigEVision
Interface	IInteger
Access	Read / Write
Unit	-
Values	≥ 0

7.20.2.15 **GevMACAddress**

MAC address of the logical link.

Name	GevMACAddress
Category	GigEVision
Interface	IInteger
Access	Read only
Unit	-
Values	≥ 0

7.20.2.16 GevMCDA

Controls the destination IP address for the message channel.

Name	GevMCDA
Category	GigEVision
Interface	Integer
Access	Read / Write
Unit	-
Values	≥ 0

7.20.2.17 GevMCPHostPort

Controls the port to which the device must send messages.

Name	GevMCPHostPort
Category	GigEVision
Interface	Integer
Access	Read / Write
Unit	-
Values	≥ 0

7.20.2.18 GevMCRC

Controls the number of retransmissions allowed when a message channel message times out.

Name	GevMCRC
Category	GigEVision
Interface	Integer
Access	Read / Write
Unit	-
Values	≥ 0

7.20.2.19 GevMCSP

This feature indicates the source port for the message channel.

Name	GevMCSP
Category	GigEVision
Interface	Integer
Access	Read only
Unit	-
Values	≥ 0

7.20.2.20 **GevMCTT**

Provides the transmission timeout value in milliseconds.

Name	GevMCTT
Category	GigE Vision
Interface	Integer
Access	Read only
Unit	ms
Values	≥ 0

7.20.2.21 **GevNumberOfInterfaces**

Indicates the number of logical links supported by this device.

Name	GevNumberOfInterfaces
Category	GigE Vision
Interface	Integer
Access	Read only
Unit	-
Values	≥ 0

7.20.2.22 **GevPAUSEFrameReception**

Controls whether incoming PAUSE Frames are handled on the given logical link.

Name	GevPAUSEFrameReception
Category	GigE Vision
Interface	Boolean
Access	Read only
Unit	-
Values	true = 1 (On) false = 0 (Off)

7.20.2.23 **GevPersistentDefaultGateway**

Controls the persistent default gateway for this logical link. It is only used when the device boots with the Persistent IP configuration scheme.

Name	GevPersistentDefaultGateway
Category	GigE Vision
Interface	Integer
Access	Read / Write
Unit	-
Values	≥ 0

7.20.2.24 **GevPersistentIPAddress**

Controls the Persistent IP address for this logical link. It is only used when the device boots with the Persistent IP configuration scheme.

Name	GevPersistentIPAddress
Category	GigEVision
Interface	Integer
Access	Read / Write
Unit	-
Values	≥ 0

7.20.2.25 **GevPersistentSubnetMask**

Controls the Persistent subnet mask associated with the Persistent IP address on this logical link. It is only used when the device boots with the Persistent IP configuration scheme.

Name	GevPersistentSubnetMask
Category	GigEVision
Interface	Integer
Access	Read / Write
Unit	-
Values	≥ 0

7.20.2.26 **GevPrimaryApplicationIPAddress**

Returns the address of the primary application.

Name	GevPrimaryApplicationIPAddress
Category	GigEVision
Interface	Integer
Access	Read only
Unit	-
Values	≥ 0

7.20.2.27 **GevPrimaryApplicationSocket**

Returns the UDP source port of the primary application.

Name	GevPrimaryApplicationSocket
Category	GigEVision
Interface	Integer
Access	Read only
Unit	-
Values	≥ 0

7.20.2.28 **GevPrimaryApplicationSwitchoverKey**

Controls the key to use to authenticate primary application switchover requests.

Name	GevPrimaryApplicationSwitchoverKey
Category	GigEVision
Interface	Integer
Access	Write only
Unit	-
Values	≥ 0

7.20.2.29 **GevSCDA**

Controls the destination IP address of the selected stream channel to which a GVSP transmitter must send data stream or the destination IP address from which a GVSP receiver may receive data stream.

Name	GevSCDA
Category	GigEVision
Interface	Integer
Access	Read / Write
Unit	-
Values	≥ 0

7.20.2.30 **GevSCFTD**

This feature indicates the delay (in timestamp counter unit) to insert between each block (image) for this stream channel.

Name	GevSCFTD
Category	GigEVision
Interface	Integer
Access	Read / Write
Unit	-
Values	0 ... 4294967295 (Increment: 1)

7.20.2.31 **GevSCPD**

Controls the delay (in timestamp counter unit) to insert between each packet for this stream channel. This can be used as a crude flow-control mechanism if the application or the network infrastructure cannot keep up with the packets coming from the device.

Name	GevSCPD
Category	GigEVision
Interface	Integer
Access	Read / Write
Unit	-
Values	0 ... 4294967295 (Increment: 1)

7.20.2.32 GevSCPHostPort

Controls the port of the selected channel to which a GVSP transmitter must send data stream or the port from which a GVSP receiver may receive data stream. Setting this value to 0 closes the stream channel.

Name	GevSCPHostPort
Category	GigEVision
Interface	Integer
Access	Read / Write
Unit	-
Values	0 ... 65535 (Increment: 1)

7.20.2.33 GevSCPInterfaceIndex

Index of the logical link to use.

Name	GevSCPInterfaceIndex
Category	GigEVision
Interface	Integer
Access	Read / Write
Unit	-
Values	0 ... 3 (Increment: 1)

7.20.2.34 GevSCPSDoNotFragment

The state of this feature is copied into the "do not fragment" bit of IP header of each stream packet. It can be used by the application to prevent IP fragmentation of packets on the stream channel.

Name	GevSCPSDoNotFragment
Category	GigEVision
Interface	Boolean
Access	Read / Write
Unit	-
Values	true = 1 (On) false = 0 (Off)

7.20.2.35 GevSCPSFireTestPacket

Sends a test packet. When this feature is set, the device will fire one test packet.

Name	GevSCPSFireTestPacket
Category	GigEVision
Interface	Boolean
Access	Read / Write
Unit	-
Values	true = 1 (On) false = 0 (Off)

7.20.2.36 GevSCPSPacketSize

Specifies the stream packet size, in bytes, to send on the selected channel for a GVSP transmitter or specifies the maximum packet size supported by a GVSP receiver.

Name	GevSCPSPacketSize
Category	GigEVision
Interface	Integer
Access	Read / Write
Unit	Byte
Values	576 ... 16110 (Increment: 2)

7.20.2.37 GevSCSP

Indicates the source port of the stream channel.

Name	GevSCSP
Category	GigEVision
Interface	Integer
Access	Read only
Unit	-
Values	≥ 0

7.20.2.38 GevSecondURL

Indicates the second URL to the GenICam XML device description file. This URL is an alternative if the application was unsuccessful to retrieve the device description file using the first URL.

Name	GevSecondURL
Category	GigEVision
Interface	IString
Access	Read only
Unit	-
Values	URL

7.20.2.39 GevStreamChannelSelector

Selects the stream channel to control.

Name	GevStreamChannelSelector
Category	GigEVision
Interface	Integer
Access	Read / Write
Unit	-
Values	≥ 0

7.20.2.40 GevSupportedOption

Returns if the selected GEV option is supported.

Name	GevSupportedOption
Category	GigEVision
Interface	IBoolean
Access	Read / Write
Unit	-
Values	true = 1 (On) false = 0 (Off)

7.20.2.41 GevSupportedOptionSelector

Selects the GEV option to interrogate for existing support.

Name	GevSupportedOptionSelector
Category	GigEVision
Interface	IEnumeration
Access	Read / Write
Unit	-
Values	see table below

Action	PacketResend
CCPApplicationSocket	PendingAck
CommandsConcatenation	PrimaryApplicationSwitchover
DiscoveryAckDelay	PTP (\geq Release 3)
DiscoveryAckDelayWritable	ScheduledAction
DynamicLAG	SerialNumber
Event	SingleLink
EventData	StandardIDMode
ExtendedStatusCodes	StaticLAG
ExtendedStatusCodesVersion2_0	StreamChannel0AllInTransmission
HeartbeatDisable	StreamChannel0BigAndLittleEndian
IEEE1588 (\leq Release 2)	StreamChannel0ExtendedChunkData
IPConfigurationDHCP	StreamChannel0IPReassembly
IPConfigurationLLA	StreamChannel0MultiZone
IPConfigurationPersistentIP	StreamChannel0PacketResendDestination
LinkSpeed	StreamChannel0UnconditionalStreaming
ManifestTable	StreamChannelSourceSocket
MessageChannelSourceSocket	TestData
MultiLink	UnconditionalAction
PAUSEFrameGeneration	UserDefinedName
PAUSEFrameReception	WriteMem

7.20.2.42 InterfaceSpeedMode

Show the interface speed mode as string.

Name	GevGVCPExtendedStatusCodesSelector	
Category	GigEVision	
Interface	IEnumeration	
Access	Read only	
Unit	-	
Values	Ethernet100Mbps	Operation at 100 Mbps.
	Ethernet10Gbps	Operation at 10 Gbps.
	Ethernet1Gbps	Operation at 1 Gbps.
	Ethernet2_5Gbps	Operation at 2.5 Gbps.
	Ethernet5Gbps	Operation at 5 Gbps.

7.20.3 PayloadSize

Provides the number of bytes transferred for each image or chunk on the stream channel at the current settings. This includes any end-of-line, end-of-frame statistics or other stamp data. This is the total size of data payload for a data block.

Name	PayloadSize
Category	TransportLayerControl
Interface	IInteger
Access	Read only
Unit	Byte
Values	0 ... depends on current settings (Increment: 1)

7.20.4 Category: TransportLayerControl → PtpControl (≥ Release 2 only)

Category that contains the features related to the Precision Time Protocol (PTP) of the device.

General Information

IEEE 1588 Precision Time Protocol (PTP) manages clock synchronization of multiple devices across an Ethernet network. On a local area network, it achieves clock accuracy in the sub-microsecond range, making it suitable for measurement and control systems.

PTP was designed to improve on existing clocksynchronization methods such as Network Time Protocol (NTP) and Global Positioning System (GPS). NTP suffers from poor accuracy, often quoted to be several milliseconds using a fast Ethernet network. GPS provides nanosecond precision using atomic clock and satellite triangulation; however, it is an expensive component to incorporate into a camera.

PTP provides microsecond precision without increasing component cost, providing better accuracy than NTP at a lower cost than GPS.

The diagram below shows the steps taken to synchronize the slave clock to that of the master.

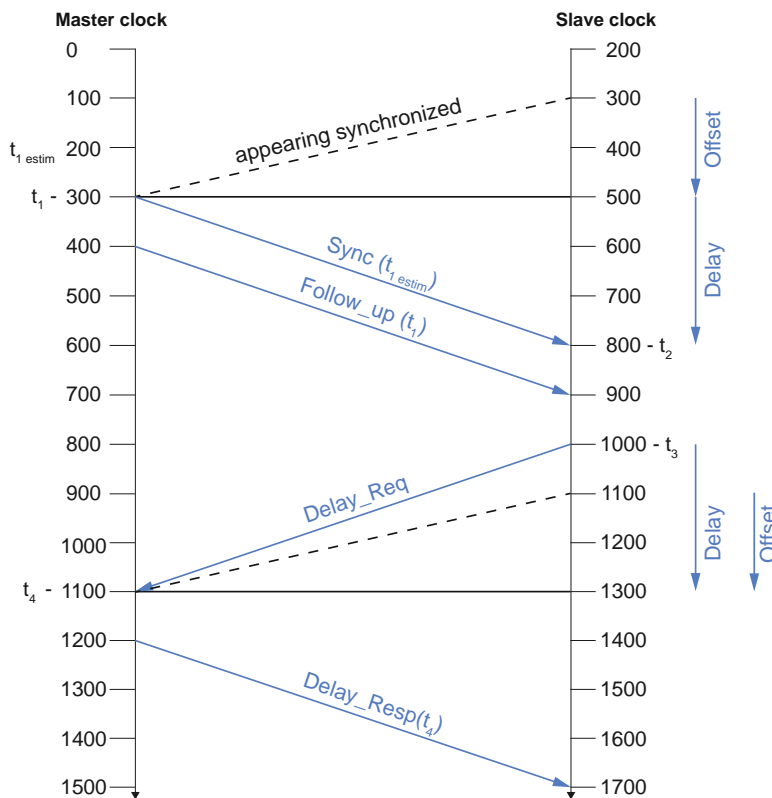

PTP synchronization

Synchronization begins when the device configured as the Master PTP clock transmits a *Sync* telegram using multicast messaging. Devices configured as Slave PTP clocks calculate the time difference between their clock and the Master PTP clock, and adjust accordingly.

Slave clock frequencies are constantly adjusted, through follow up and delay messages, to keep their clock value as close as possible to the master clock. While all Slave clocks are within 1 μ s of the master, PTP sync is achieved.

Notice
Release ≥ 3 only
The feature <i>PtpServoStatusThreshold</i> can be used to set the time threshold when the transition from <code>PtpServoStatus = Unknown</code> to <code>PtpServoStatus = Locked</code> is done and back.

Network Topology without GPS Clock

Achieving PTP synchronization between multiple cameras requires all cameras to be on the same network/subnet. The IEEE 1588 best master clock algorithm will select a camera as the master clock. Each camera will synchronize to this master clock.

This restriction is due to the current inability of any network card hardware to forward PTP sync multicast packets between ports within the 1 μ s requirement.

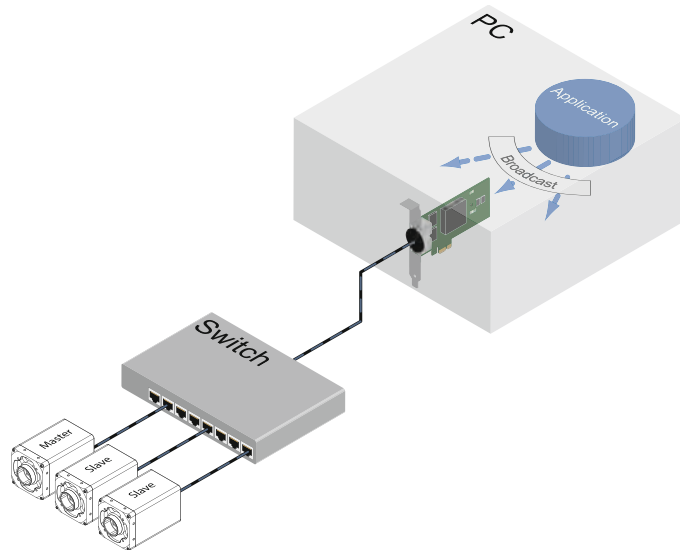

Network Topology with GPS Clock

The cameras can be synchronized to a GPS timer, allowing “real world time” synchronization. Configure *PtpMode* on all of the cameras to *Slave* or *Auto*. In *Auto*, the IEEE 1588 best master clock algorithm will elect the GPS clock as the master. Each camera will synchronize to the GPS master clock.

Notice

To ensure a reliable synchronization, the GPS master clock must be configured with a Sync interval between 0.5 s and 2 s (according to the Default PTP profile for use with the delay request-response mechanism).

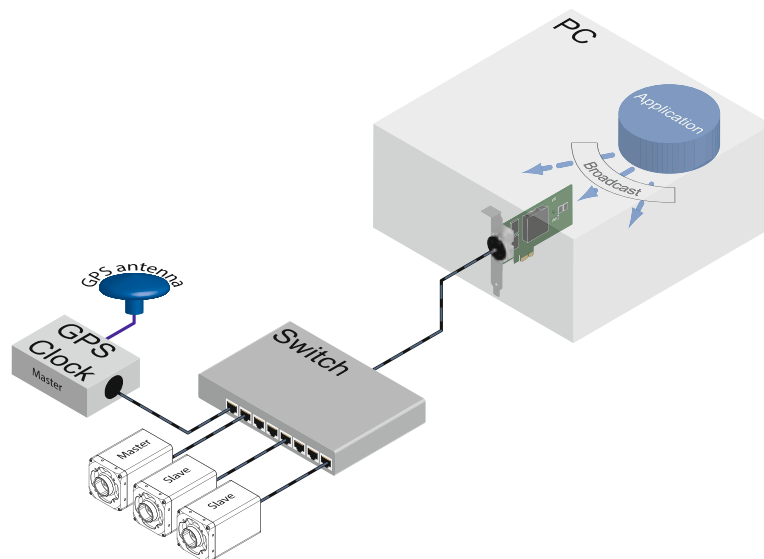

7.20.4.1 PtpClockAccuracy

Indicates the expected accuracy of the device PTP clock when it is the grandmaster, or in the event it becomes the grandmaster.

Name	PtpClockAccuracy
Category	TansportLayerControl → PtpControl
Interface	IEnumeration
Access	Read only
Unit	-
Values	see table below

Notice

The camera supports an accuracy of Within 100µs.

GreaterThan10s	Within1us
Unknown	Within250ms.
Within100ms	Within250ns
Within100ns	Within250us
Within100us	Within25ms
Within10ms	Within25ns
Within10s	Within25us
Within10us	Within2p5ms
Within1ms	Within2p5us
Within1s	

7.20.4.2 PtpClockID

Returns the latched clock ID of the PTP device.

Notice

Byte 0 of the IEEE ClockIdentity field is mapped to the MSB.

Name	PtpClockID
Category	TansportLayerControl → PtpControl
Interface	IInteger
Access	Read only
Unit	-
Values	80-00-00-00-00-00 ... 7F-FF-FF-FF-FF-FF-FF (Increment: 1)

7.20.4.3 PtpDataSetLatch

Latches the current values from the device's PTP clock data set.

Name	PtpDataSetLatch
Category	TansportLayerControl → PtpControl
Interface	ICommand
Access	Write only
Unit	-
Values	-

7.20.4.4 PtpEnable

Enables the Precision Time Protocol (PTP).

Notice

To write this feature, set `TLParamsLocked = 0`.

Notice

By deactivating `EnergyEfficientEthernetEnable`, higher accuracy may be achieved when using PTP.

Name	PtpEnable
Category	TansportLayerControl → PtpControl
Interface	IBoolean
Access	Read/Write
Unit	-
Values	true = 1 (On)
	false = 0 (Off)

7.20.4.5 PtpGrandmasterClockID

Returns the latched grandmaster clock ID of the PTP device. The grandmaster clock ID is the clock ID of the current grandmaster clock.

Notice

Byte 0 of the IEEE ClockIdentity field is mapped to the MSB.

Name	PtpGrandmasterClockID
Category	TansportLayerControl → PtpControl
Interface	IInteger
Access	Read only
Unit	-
Values	80-00-00-00-00-00 ... 7F-FF-FF-FF-FF-FF-FF (Increment: 1)

7.20.4.6 PtpMode

Selects the PTP clock type the device will act as.

Name	PtpMode	
Category	TansportLayerControl → PtpControl	
Interface	IEnumeration	
Access	Read/Write	
Unit	-	
Values	Auto	The device uses the IEEE 1588 best master clock algorithm to determine which device is master, and which devices are slaves. In case the device is not the best master, it will act as a PTP slave.
	Slave	The device's clock will act as a PTP slave only to align with a master device's clock.

7.20.4.7 PtpOffsetFromMaster

Returns the latched offset from the PTP master clock in nanoseconds.

Name	PtpOffsetFromMaster
Category	TansportLayerControl → PtpControl
Interface	Integer
Access	Read only
Unit	ns
Values	-9223372036854775808 ... 9223372036854775808 (Increment: 1)

7.20.4.8 PtpParentClockID

Returns the latched parent clock ID of the PTP device. The parent clock ID is the clock ID of the current master clock.

Notice

Byte 0 of the IEEE ClockIdentity field is mapped to the MSB.

Name	PtpParentClockID
Category	TansportLayerControl → PtpControl
Interface	Integer
Access	Read only
Unit	-
Values	80-00-00-00-00-00 ... 7F-FF-FF-FF-FF-FF-FF (Increment: 1)

7.20.4.9 PtpServoStatus

Notice

PTPServoStatus may change temporarily when changing the IP address.

Returns the latched state of the clock servo.

When the servo is in a locked state, the value returned is 'Locked'. When the servo is in a non-locked state, a device-specific value can be returned to give specific information. If no device-specific value is available to describe the current state of the clock servo, the value should be 'Unknown'.

Name	PtpServoStatus
Category	TansportLayerControl → PtpControl
Interface	IEnumeration
Access	Read only
Unit	-
Values	Unknown Locked

7.20.4.10 PtpServoStatusThreshold

Threshold of time difference to Ptp Master Clock for transition PtpServoStatus Unknown to Locked.

Name	PtpServoStatusThreshold
Category	TansportLayerControl → PtpControl
Interface	Integer
Access	Read only
Unit	µs
Values	1 ... 10000 (Increment: 1)

7.20.4.11 PtpStatus

Returns the latched state of the PTP clock.

Name	PtpStatus	
Category	TansportLayerControl → PtpControl	
Interface	IEnumeration	
Access	Read only	
Unit	-	
Values	Disabled	PTP is disabled.
	Faulty	The fault state of the protocol.
	Initializing	PTP is being initialized.
	Listening	Device is listening for other PTP enabled devices.
	Master	Device acting as master clock.
	Passive	If there are 2 or more devices with PtpMode = Master, this device has an inferior clock and is not synchronized to the master.
	Pre_Master	The port shall behave in all respects as though it were in the MASTER state except that it shall not place any messages on its communication path except for Pdelay_Req, Pdelay_Resp, Pdelay_Resp_Follow_Up, signaling, or management messages.
	Slave	PTP synchronization between this device and master is achieved.
	Uncalibrated	PTP synchronization not yet achieved.

7.20.4.12 PtpSyncMessageInterval (≥ Release 3 only)

Returns the latched sync message interval from the PTP master clock in milliseconds.

Name	PtpSyncMessageInterval
Category	TansportLayerControl → PtpControl
Interface	IFloat
Access	Read only
Unit	ms
Values	≥ 0

7.20.4.13 PtpSyncMessageIntervalStatus (≥ Release 3 only)

Returns if the latched sync message interval from the PTP master clock is supported by the device. An unsupported sync message interval may result in PtpServoStatus instability.

Name	PtpSyncMessageIntervalStatus	
Category	TransportLayerControl → PtpControl	
Interface	IEnumeration	
Access	Read only	
Unit	-	
Values	Valid	Sync message interval is valid and supported by the device.
	Invalid	Sync message interval is not valid. This may result in PtpServoStatus instability.

7.21 Category: UserSetControl

Category that contains the User Set control features. It allows loading or saving factory or user-defined settings.

Loading the factory default User Set guarantees a state where a continuous acquisition can be started using only the mandatory features.

These user sets are stored within the camera and can be loaded, saved and transferred to other cameras.

By using *User Set Default* one of these four user sets can be set as the default, which means that the camera starts up with these adjusted parameters.

7.21.1 UserSetDefault

Four user sets are available for this camera. *User Set 1*, *User Set 2*, *User Set 3* are user-specific and can contain user-definable parameters.

Selects the feature *UserSet* to load and make active by default when the device is reset. The factory settings are stored in the user set *Default*. This is the only user set that cannot be edited.

Notice

All saved user sets can be set as default.

Name	UserSetDefault	
Category	UserSetControl	
Interface	IEnumeration	
Access	Read / Write	
Unit	-	
Values	Default	Select the factory setting user set.
	User Set 1	Select the User Set 1 (available when saved).
	User Set 2	Select the User Set 2 (available when saved).
	User Set 3	Select the User Set 3 (available when saved).

7.21.2 UserSetFeatureEnable

Enables the selected feature and make it active in all the UserSets.

Name	UserSetFeatureEnable
Category	UserSetControl
Interface	IBoolean
Access	Read only
Unit	-
Values	true = 1 (On) false = 0 (Off)

7.21.3 UserSetFeatureSelector

Selects which individual UserSet feature to control.

Name	UserSetFeatureSelector
Category	UserSetControl
Interface	IEnumeration
Access	Read / Write
Unit	-
Values	see table below

Parameter		
AcquisitionFrameCount	ExposureAutoMaxValue (≥ Rel. 2)	LinePWMMaxDutyCycle
AcquisitionFrameRate	ExposureAutoMinValue (≥ Rel. 2)	LinePWMMode
AcquisitionFrameRate-Enable	ExposureMode	LineSource
AcquisitionMode	ExposureTime	OffsetX
ActionDeviceKey	FrameCounter	OffsetY
ActionGroupKey	Gain	PixelFormat
ActionGroupMask	GainAuto (≥ Rel. 2)	PtpEnable (≥ Rel. 2)
AutoFeatureHeight (≥ Rel. 2)	GainAutoMaxValue (≥ Rel. 2)	PtpMode (≥ Rel. 2)
AutoFeatureOffsetX (≥ Rel. 2)	GainAutoMinValue (≥ Rel. 2)	ReadoutMode
AutoFeatureOffsetY (≥ Rel. 2)	Gamma	ReverseX
AutoFeatureRegionMode (≥ Rel. 2)	GevSCFTD	ReverseY
AutoFeatureRegionReference (≥ Rel. 2)	GevSCPD	SensorADDigitization
AutoFeatureWidth (≥ Rel. 2)	HDR Enable	SensorShutterMode (≥ Rel. 2)
BalanceWhiteAuto	HDRExposure TimeRatio	SequencerSetNext
BinningHorizontal	HDRProcessingEnable	SequencerSetStart
BinningHorizontalMode	HDRProcessingThreshold- Max	SequencerTrigger- Activation

BinningVertical	HDRProcessingThreshold-Min	SequencerTrigger-Source
BinningVerticalMode	HDRSplitviewEnable	ShortExposureTimeEnable
BlackLevel	HDRTonemappingCurveGradient	TestPattern
BrightnessAutoNominal-Value	HDRTonemappingCurveGradientpoint	TimerDelay
BrightnessAutoPriority	HDRTonemappingCurveOffset	TimerDuration
ChunkEnable	HDRTonemappingEnable	TimerTriggerActivation
ChunkModeActive	Height	TimerTriggerSource
ColorTransformationAuto	ImageCompressionMode	TransferStart
CounterDuration	ImageCompressionQuality	TransferStop
CounterEventActivation	LUTContent	TriggerActivation
CounterEventSource	LUTEnable	TriggerDelay
CounterResetActivation	LUTValue	TriggerMode
CounterResetSource	LineDebouncerHighTime-Abs	TriggerSource
DefectPixelCorrection	LineDebouncerLowTime-Abs	UserOutputValue
DeviceLinkThroughputLimit	LineInverter	UserOutputValueAll
DeviceTemperature-StatusTransition	LinePWMDuration	Width
EventNotification	LinePWMDutyCycle	
ExposureAuto (≥ Rel. 2)	LinePWMMaxDuration	

7.21.4 UserSetLoad

Loads the *UserSet* specified by *UserSetSelector* to the device and makes it active.

Notice

Loading a *UserSet* requires the stop of the camera.

Name	UserSetLoad
Category	UserSetControl
Interface	ICommand
Access	Write only
Unit	-
Values	-

7.21.5 UserSetSave

Save the User Set specified by *UserSetSelector* to the non-volatile memory of the device

Notice

The factory settings are stored in the user set *Default*. This is the only user set that cannot be edited. Select at *UserSetSelector* *UserSet1*, *UserSet2* or *UserSet3*.

Name	UserSetSave
Category	UserSetControl
Interface	ICommand
Access	Write only
Unit	-
Values	-

7.21.6 UserSetSelector

Selects the Feature User Set to load, save or configure. The factory settings are stored in the user set *Default*. This is the only user set that cannot be edited.

Name	UserSetSelector	
Category	UserSetControl	
Interface	IEnumeration	
Access	Read / Write	
Unit	-	
Values	Default	Select the factory setting user set.
	User Set 1	Select the User Set 1.
	User Set 2	Select the User Set 2.
	User Set 3	Select the User Set 3.

7.22 Category: boSerialControl

Category for the serial control features.

7.22.1 boSerialASCIIReadBuffer

Buffer for exchanging ASCII data over the serial interface. This buffer uses the same memory as *boSerialBinaryReadBuffer*.

Name	boSerialASCIIReadBuffer
Category	boSerialControl
Interface	IString
Access	Read only
Unit	-
Values	-

7.22.2 boSerialASCIIWriteBuffer

Buffer for exchanging ASCII data over the serial interface. This buffer uses the same memory as *boSerialBinaryWriteBuffer*.

Name	boSerialASCIIWriteBuffer
Category	boSerialControl
Interface	IString
Access	Read / Write
Unit	-
Values	-

7.22.3 boSerialBinaryReadBuffer

Buffer for exchanging binary data over the serial interface. This buffer uses the same memory as *boSerialASCIIReadBuffer*.

Name	boSerialBinaryReadBuffer
Category	boSerialControl
Interface	IRegister
Access	Read only
Unit	-
Values	Memory Address: e.g. 0x40004258 (Length: 32) Varies depending on the value of the <i>boSerialSelector</i> .

7.22.4 boSerialBinaryWriteBuffer

Buffer for exchanging binary data over the serial interface. This buffer uses the same memory as *boSerialASCIIWriteBuffer*.

Name	boSerialBinaryWriteBuffer
Category	boSerialControl
Interface	IRegister
Access	Read / Write
Unit	-
Values	Memory Address: e.g. 0x40004224 (Length: 32) Varies depending on the value of the <i>boSerialSelector</i> .

7.22.5 boSerialBytesAvailableForRead

When refreshed number of available data bytes for read are shown.

Name	boSerialBytesAvailableForRead
Category	boSerialControl
Interface	IInteger
Access	Read only
Unit	-
Values	0 ... 4294967295 (Increment: 1)

7.22.6 boSerialBytesRead

Length of data read with last SerialRead command.

Name	boSerialBytesRead
Category	boSerialControl
Interface	IInteger
Access	Read only
Unit	-
Values	0 ... 32 (Increment: 1)

7.22.7 boSerialBytesToRead

Length of data to read.

Name	boSerialBytesToRead
Category	boSerialControl
Interface	IInteger
Access	Read / Write
Unit	-
Values	0 ... 32 (Increment: 1)

7.22.8 boSerialBytesToWrite

Length of data to write.

Name	boSerialBytesToWrite
Category	boSerialControl
Interface	Integer
Access	Read / Write
Unit	-
Values	0 ... 32 (Increment: 1)

7.22.9 boSerialBytesWritten

Length of data written with last boSerialWrite command.

Name	boSerialBytesWritten
Category	boSerialControl
Interface	Integer
Access	Read only
Unit	-
Values	0 ... 32 (Increment: 1)

7.22.10 boSerialConfigBaudRate

Serial interface clock frequency.

Name	boSerialConfigBaudRate	
Category	boSerialControl	
Interface	IEnumeration	
Access	Read / Write	
Unit	-	
Values	Baudrate 9600 Hz	Serial interface clock frequency is 9600 Hz.
	Baudrate 19200 Hz	Serial interface clock frequency is 19200 Hz.
	Baudrate 38400 Hz	Serial interface clock frequency is 38400 Hz.
	Baudrate 57600 Hz	Serial interface clock frequency is 57600 Hz.
	Baudrate 115200 Hz	Serial interface clock frequency is 115200 Hz.

7.22.11 boSerialConfigDataBits

Number of data bits.

Name	boSerialConfigDataBits	
Category	boSerialControl	
Interface	IEnumeration	
Access	Read only	
Unit	-	
Values	Five	Serial data bits are 5.
	Six	Serial data bits are 6.
	Seven	Serial data bits are 7.
	Eight	Serial data bits are 8.

7.22.12 boSerialConfigParity

Serial interface parity.

Name	boSerialConfigParity	
Category	boSerialControl	
Interface	IEnumeration	
Access	Read only	
Unit	-	
Values	Even	Serial parity is even.
	Mark	Serial parity is mark.
	None	Serial parity is none.
	Odd	Serial parity is odd.
	Space	Serial parity is space.

7.22.13 boSerialConfigStopBits

Number of stop bits.

Name	boSerialConfigStopBits	
Category	boSerialControl	
Interface	IEnumeration	
Access	Read only	
Unit	-	
Values	One	Serial stop bit is one.
	One Pt Five	Serial stop bit is one pt five.
	Two	Serial stop bits are two.

7.22.14 boSerialMode

States the interface mode of the serial interface.

Name	boSerialMode	
Category	boSerialControl	
Interface	IEnumeration	
Access	Read only	
Unit	-	
Values	Bypass (except .EF)	UART1 of Power and Process Interface and UART0 Interface are connected.
	Off	The serial interface is off and shall not be used
	Optic Control	The serial interface shall be used for optic control.
	bo Serial Control	The serial interface shall be used for bo serial control.

7.22.15 boSerialRead

Command to read data from serial interface.

Name	boSerialRead	
Category	boSerialControl	
Interface	ICommand	
Access	Write only	
Unit	-	
Values	-	

7.22.16 boSerialSelector

Selects which serial interface to configure.

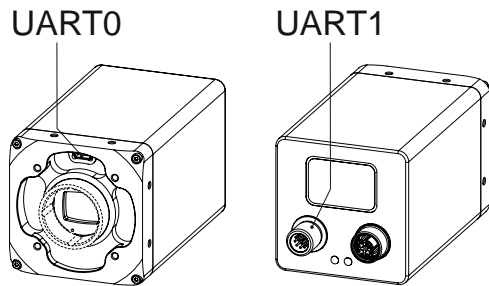

Name	boSerialSelector	
Category	boSerialControl	
Interface	IEnumeration	
Access	Read / Write	
Unit	-	
Values	UART0	Selects the UART0 Interface which can be used, for example, to control optical components.
	UART1	Selects the UART1 Interface which is part of the Power and Process Interface and can be used for RS232 communication.

7.22.17 boSerialStatus

Result of the serial error detection mechanism. The value is reset with each read access. Several bits can be set simultaneously.

Name	boSerialStatus
Category	boSerialControl
Interface	Integer
Access	Read only
Unit	-
	0x0 ... 0xFFFFFFFF (Increment: 1)
	The hexadecimal value is to be interpreted as follows:
Values	0x00000010 break detect 0x00000008 framing error 0x00000004 parity error 0x00000002 receive overrun error

7.22.18 boSerialWrite

Command to write data to serial interface.

Name	boSerialWrite
Category	boSerialControl
Interface	ICommand
Access	Write only
Unit	-
Values	-

8. Interface Functionalities

8.1 Device Information

By using GigE all data packets are sequentially transmitted over one cable. At the beginning of a frame will be transmitted a Leader and at the end will be transmitted a Trailer.

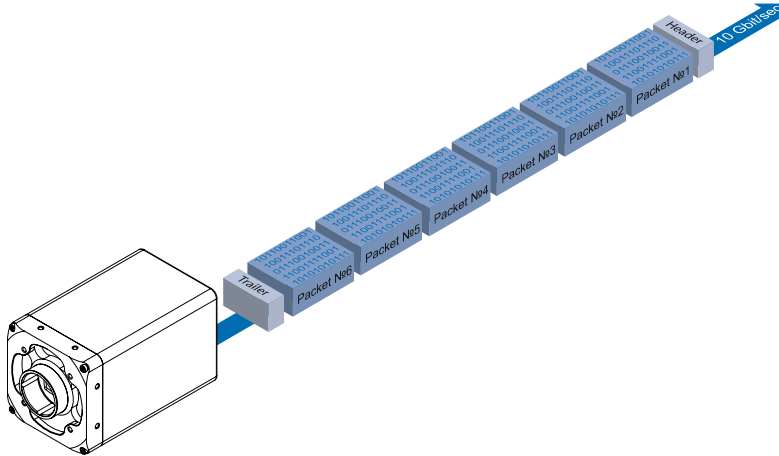

8.2 Packet Size and Maximum Transmission Unit (MTU)

Network packets can be of different sizes. The size depends on the network components employed. When using GigE Vision®- compliant devices, it is generally recommended to use larger packets. On the one hand the overhead per packet is smaller, on the other hand larger packets cause less CPU load.

The packet size of UDP packets can differ from 576 Bytes up to the MTU.

The MTU describes the maximal packet size which can be handled by all network components involved.

In principle modern network hardware supports a packet size of 1518 Bytes, which is specified in the network standard. However, so-called "Jumbo frames" are on the advance as Gigabit Ethernet continues to spread. "Jumbo frames" merely characterizes a packet size exceeding 1500 Bytes.

Baumer VLXT cameras can handle a MTU of up to 16384 Bytes.

8.3 Inter Packet Gap (IPG)

To achieve optimal results in image transfer, several Ethernet-specific factors need to be considered when using Baumer cameras.

Upon starting the image transfer of a camera, the data packets are transferred at maximum transfer speed (1 Gbit/s / 10 Gbit/s). In accordance with the network standard, Baumer employs a minimal separation of 12 Bytes between two packets. This separation is called "Inter Packet Gap" (IPG). In addition to the minimal PD, the GigE Vision® standard stipulates that the PD be scalable (user-defined).

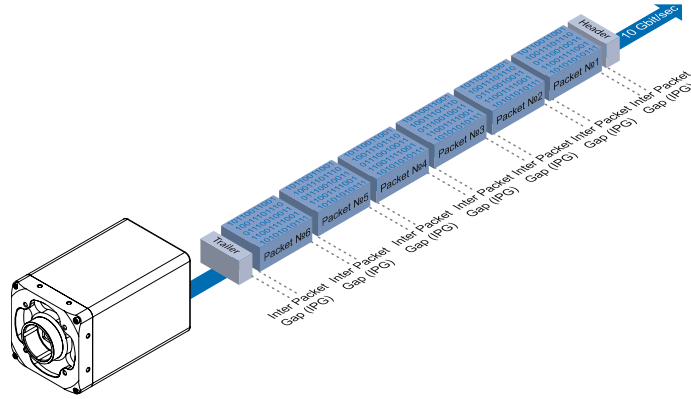

8.3.1 Example 1: Multi Camera Operation – Minimal IPG

Setting the IPG to minimum means every image is transferred at maximum speed. Even by using a frame rate of 1 fps this results in full load on the network. Such "bursts" can lead to an overload of several network components and a loss of packets. This can occur, especially when using several cameras.

In the case of two cameras sending images at the same time, this would theoretically occur at a transfer rate of 2 Gbits/s. The switch has to buffer this data and transfer it at a speed of 1 Gbit/s afterwards. Depending on the internal buffer of the switch, this operates without any problems up to n cameras ($n \geq 1$). More cameras would lead to a loss of packets. These lost packets can however be saved by employing an appropriate resend mechanism, but this leads to additional load on the network components.

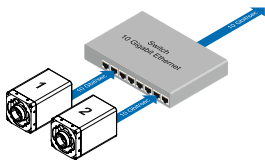

Operation of two cameras employing a Ethernet switch.
Data processing within the switch is displayed in the next two figures.

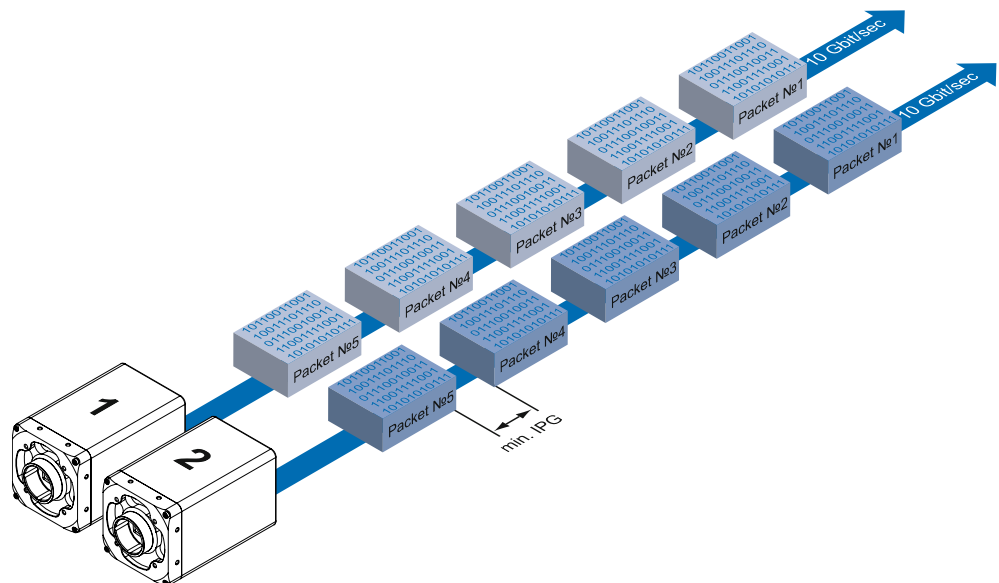

8.3.2 Example 2: Multi Camera Operation – Optimal IPG

A better method is to increase the IPG to a size of

$$\text{optimal IPG} = \text{packet size} + 2 \times \text{minimal IPG}$$

In this way both data packets can be transferred successively (zipper principle), and the switch does not need to buffer the packets.

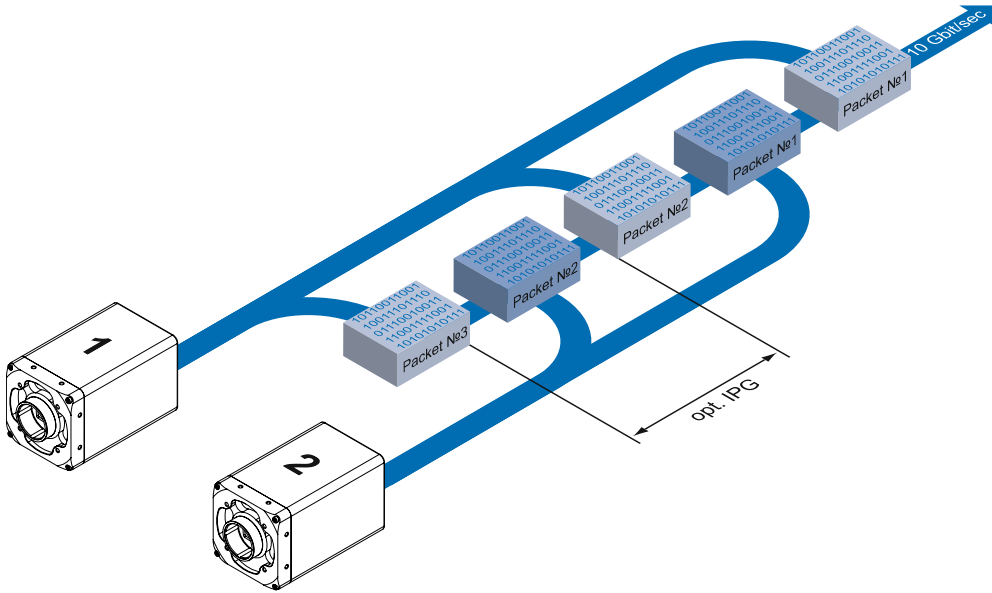

Max. IPG:
On the Gigabit Ethernet the max. IPG and the data packet must not exceed 1 Gbit. Otherwise data packets can be lost.

8.4 Frame Delay

Another approach for packet sorting in multi-camera operation is the so-called Frame Delay. Due to the fact, that the currently recorded image is stored within the camera and its transmission starts with a predefined delay, complete images can be transmitted to the PC at once.

The following figure should serve as an example:

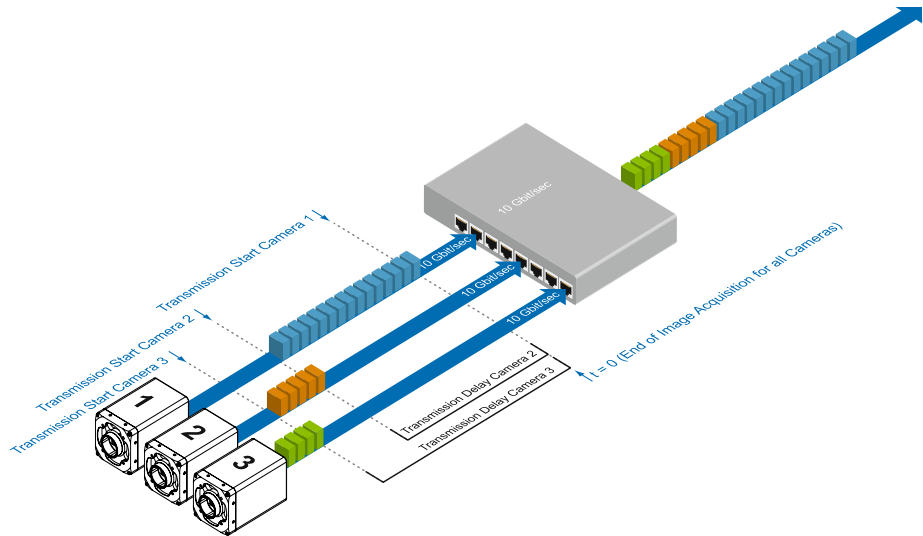

Due to process-related circumstances, the image acquisitions of all cameras end at the same time. Now the cameras are not trying to transmit their images simultaneously, but – according to the specified transmission delays – subsequently. Thereby the first camera starts the transmission immediately – with a transmission delay "0".

8.4.1 Time Saving in Multi-Camera Operation

As previously stated, the Frame delay feature was especially designed for multi-camera operation with employment of different camera models. Just here an significant acceleration of the image transmission can be achieved:

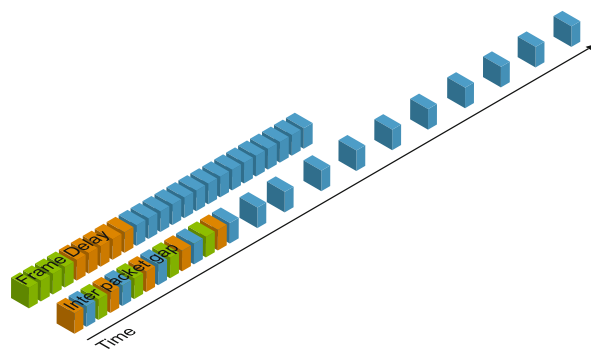

For the above mentioned example, the employment of the transmission delay feature results in a time saving – compared to the approach of using the inter packet gap – of approx. 45% (applied to the transmission of all three images).

8.4.2 Configuration Example (GigE)

For the three used cameras the following data are known:

Camera	Sensor Resolution [Pixel]	Pixel Format (Pixel Depth) [bit]	Data Volume [bit]	Readout Time [ms]	Exposure Time [ms]	Transfer Time [ms]
1	1392 × 1040	8	11581440	50	32	≈ 11.6
2	776 × 582	8	3613056	15.5	32	≈ 3.6
3	656 × 494	8	2592512	11	32	≈ 2.6

- The sensor resolution and the readout time ($t_{readout}$) can be found in the respective Technical Data Sheet (TDS). For the example a full frame resolution is used.
- The exposure time ($t_{exposure}$) is manually set to 15 ms.
- The resulting data volume is calculated as follows:

$$\text{Resulting Data Volume} = \text{horizontal Pixels} \times \text{vertical Pixels} \times \text{Pixel Depth}$$
- The transfer time ($t_{transfer10GigE}$) is calculated as follows:

$$\text{Transfer Time} = \text{Resulting Data Volume} / (1000 \times 1000) \text{ [ms]}$$

All the cameras are triggered simultaneously.

The transmission delay is realized as a counter, that is started immediately after the sensor readout is started.

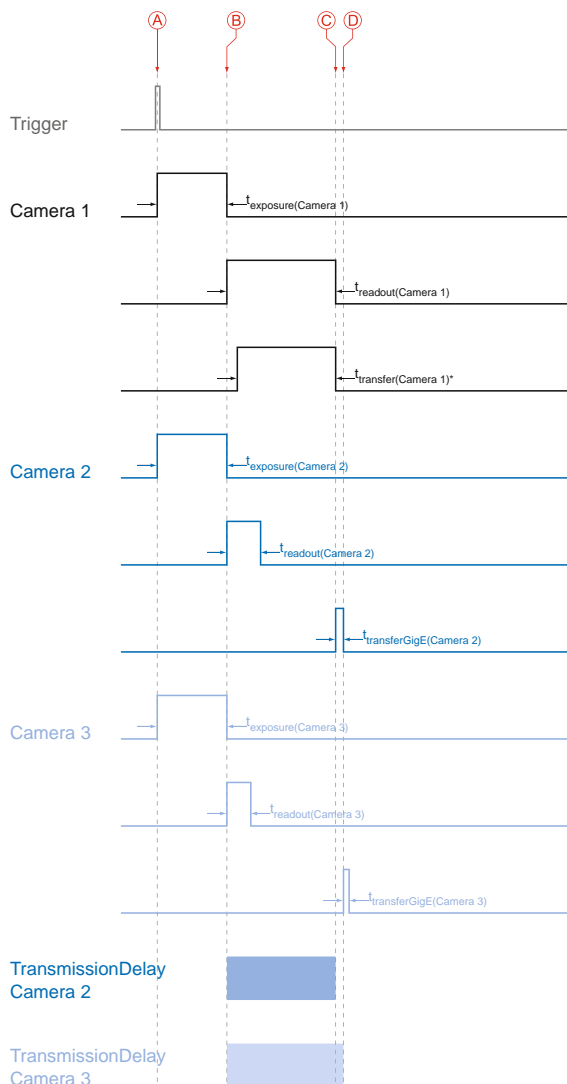

Timings:

- A - exposure start for all cameras
- B - all cameras ready for transmission
- C - transmission start camera 2
- D - transmission start camera 3

* Due to technical issues the data transfer of camera 1 does not take place with full speed.

In general, the transmission delay is calculated as:

$$t_{TransmissionDelay(Camera\ n)} = t_{exposure(Camera\ 1)} + t_{readout(Camera\ 1)} - t_{exposure(Camera\ n)} + \sum_{n=3}^n t_{transferGigE(Camera\ n-1)}$$

Therewith for the example, the transmission delays of camera 2 and 3 are calculated as follows:

$$t_{TransmissionDelay(Camera\ 2)} = t_{exposure(Camera\ 1)} + t_{readout(Camera\ 1)} - t_{exposure(Camera\ 2)}$$

$$t_{TransmissionDelay(Camera\ 3)} = t_{exposure(Camera\ 1)} + t_{readout(Camera\ 1)} - t_{exposure(Camera\ 3)} + t_{transfer10Gige(Camera\ 2)}$$

Solving this equations leads to:

$$t_{TransmissionDelay(Camera\ 2)} = 32\ ms + 50\ ms - 32\ ms = 50\ ms$$

$$t_{TransmissionDelay(Camera\ 3)} = 32\ ms + 50\ ms - 32\ ms + 2.6\ ms = 52.6\ ms$$

8.5 Multicast

Multicasting offers the possibility to send data packets to more than one destination address – without multiplying bandwidth between camera and Multicast device (e.g. Router or Switch).

The data is sent out to an intelligent network node, an IGMP (Internet Group Management Protocol) capable Switch or Router and distributed to the receiver group with the specific address range.

In the example on the figure below, multicast is used to process image and message data separately on two different PC's.

Multicast Addresses:
<i>For multicasting Bauer suggests an address range from 232.0.1.0 to 232.255.255.255.</i>

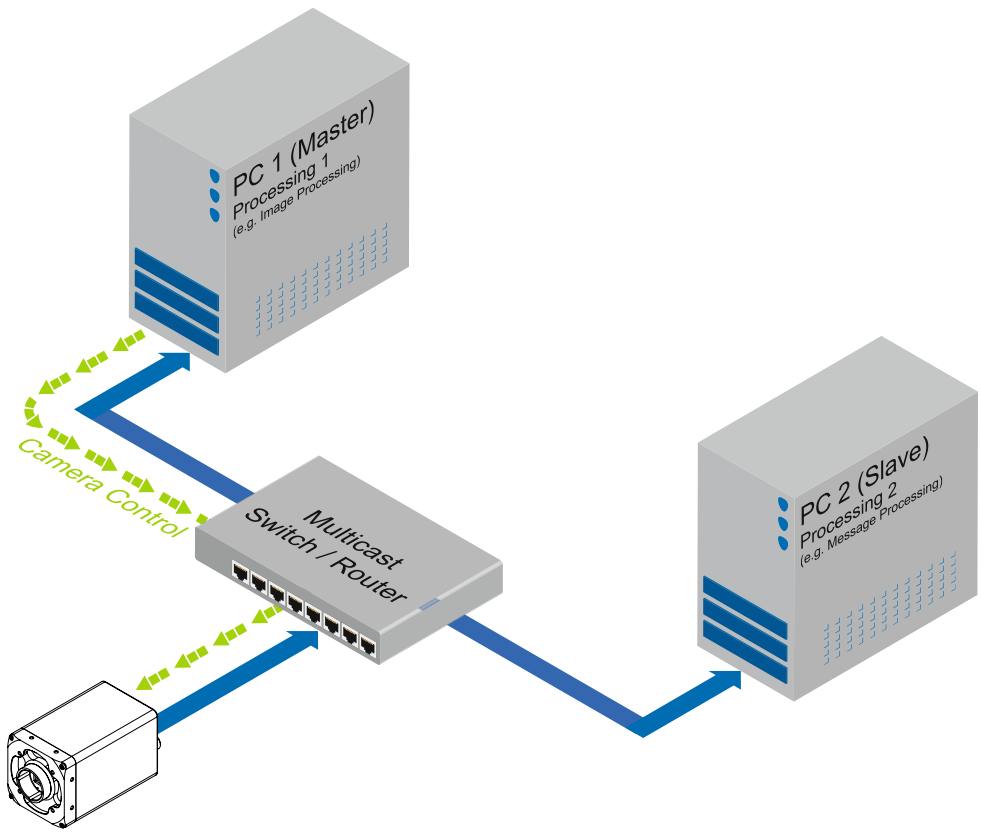

Internet Protocol:
On Baumer cameras IP v4 is employed.

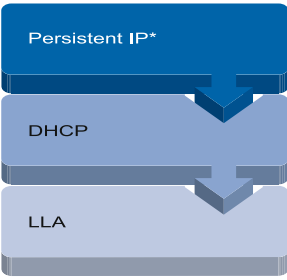

▲ Connection pathway for Baumer Gigabit Ethernet cameras:
The device connects step by step via the three described mechanisms.

DHCP:
Please pay attention to the DHCP Lease Time.

8.6 IP Configuration

8.6.1 Persistent IP

A persistent IP address is assigned permanently. Its validity is unlimited.

Notice

Please ensure a valid combination of IP address and subnet mask.

IP range:	Subnet mask:
0.0.0.0 – 127.255.255.255	255.0.0.0
128.0.0.0 – 191.255.255.255	255.255.0.0
192.0.0.0 – 223.255.255.255	255.255.255.0

These combinations are not checked by Baumer GAPI, Baumer GAPI Viewer or camera on the fly. This check is performed when restarting the camera, in case of an invalid IP - subnet combination the camera will start in LLA mode.

* This feature is disabled by default.

8.6.2 DHCP (Dynamic Host Configuration Protocol)

The DHCP automates the assignment of network parameters such as IP addresses, subnet masks and gateways. This process takes up to 12 s.

Once the device (client) is connected to a DHCP-enabled network, four steps are processed:

- **DHCP Discovery**

In order to find a DHCP server, the client sends a so called DHCPDISCOVER broadcast to the network.

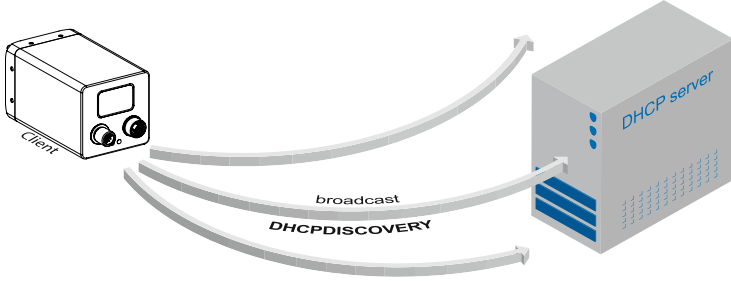

- **DHCP Offer**

After reception of this broadcast, the DHCP server will answer the request by a unicast, known as DHCP OFFER. This message contains several items of information, such as:

Information for the client	MAC address
	offered IP address
Information on server	IP address
	subnet mask
	duration of the lease

▪ **DHCP Request**

Once the client has received this DHCP OFFER, the transaction needs to be confirmed. For this purpose the client sends a so called DHCPREQUEST broadcast to the network. This message contains the IP address of the offering DHCP server and informs all other possible DHCP servers that the client has obtained all the necessary information, and there is therefore no need to issue IP information to the client.

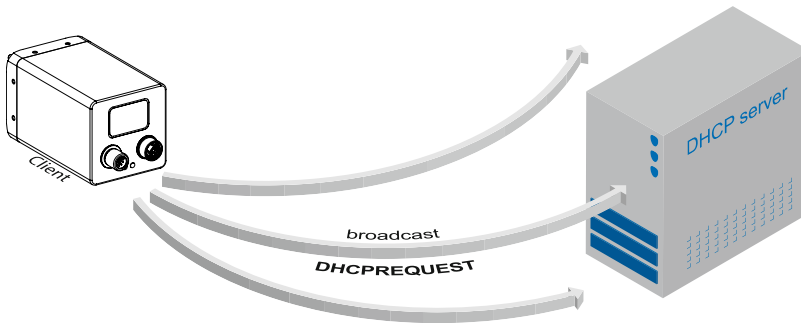

▪ **DHCP Acknowledgement**

Once the DHCP server obtains the DHCPREQUEST, a unicast containing all necessary information is sent to the client. This message is called DHCPACK. According to this information, the client will configure its IP parameters and the process is complete.

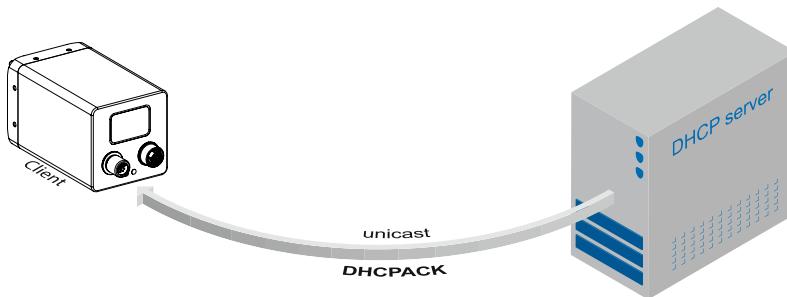

DHCP Lease Time:
The validity of DHCP IP addresses is limited by the lease time. When this time is elapsed, the IP configuration needs to be redone. This causes a connection abort.

8.6.3 LLA

LLA (Link-Local Address) refers to a local IP range from 169.254.0.1 to 169.254.254.254 and is used for the automated assignment of an IP address to a device when no other method for IP assignment is available.

The IP address is determined by the host, using a pseudo-random number generator, which operates in the IP range mentioned above.

Once an address is chosen, this is sent together with an ARP (Address Resolution Protocol) query to the network to check if it already exists. Depending on the response, the IP address will be assigned to the device (if not existing) or the process is repeated. This method may take some time - the GigE Vision® standard stipulates that establishing connection in the LLA should not take longer than 40 seconds, in the worst case it can take up to several minutes.

LLA:
Please ensure operation of the PC within the same subnet as the camera.

8.6.4 Force IP*)

Inadvertent faulty operation may result in connection errors between the PC and the camera. In this case "Force IP" may be the last resort. The Force IP mechanism sends an IP address and a subnet mask to the MAC address of the camera. These settings are sent without verification and are adapted immediately by the client. They remain valid until the camera is de-energized.

*) In the GigE Vision® standard, this feature is defined as "Static IP".

8.7 Packet Resend

Due to the fact, that the GigE Vision® standard stipulates using a UDP – a stateless user datagram protocol – for data transfer, a mechanism for saving the "lost" data needs to be employed.

Here, a resend request is initiated if one or more packets are damaged during transfer and – due to an incorrect checksum – rejected afterwards.

On this topic one must distinguish between three cases:

8.7.1 Normal Case

In the case of unproblematic data transfer, all packets are transferred in their correct order from the camera to the PC. The probability of this happening is more than 99%.

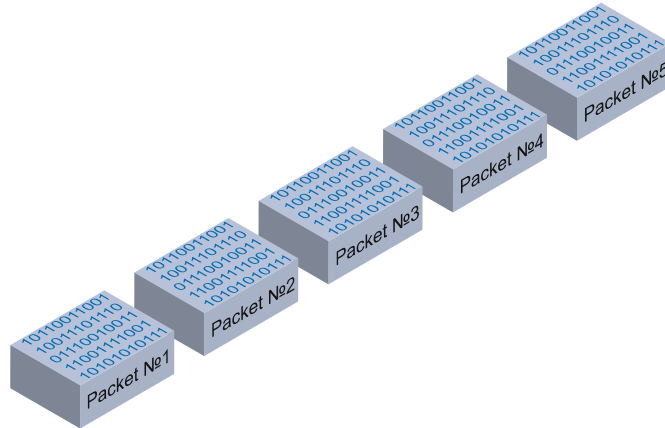

8.7.2 Fault 1: Lost Packet within Data Stream

If one or more packets are lost within the data stream, this is detected by the fact, that packet number n is not followed by packet number $(n+1)$. In this case the application sends a resend request (A). Following this request, the camera sends the next packet and then resends (B) the lost packet.

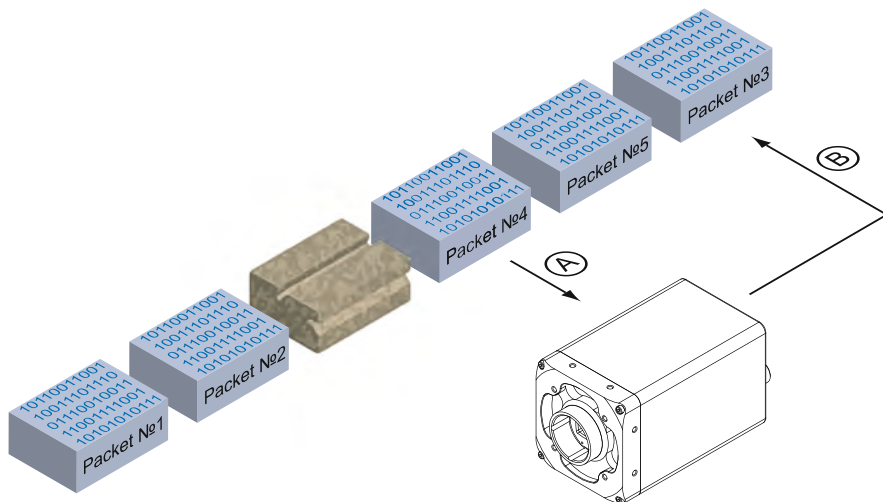

In our example packet no. 3 is lost. This fault is detected on packet no. 4, and the resend request triggered. Then the camera sends packet no. 5, followed by resending packet no. 3.

8.7.3 Fault 2: Lost Packet at the End of the Data Stream

In case of a fault at the end of the data stream, the application will wait for incoming packets for a predefined time. When this time has elapsed, the resend request is triggered and the "lost" packets will be resent.

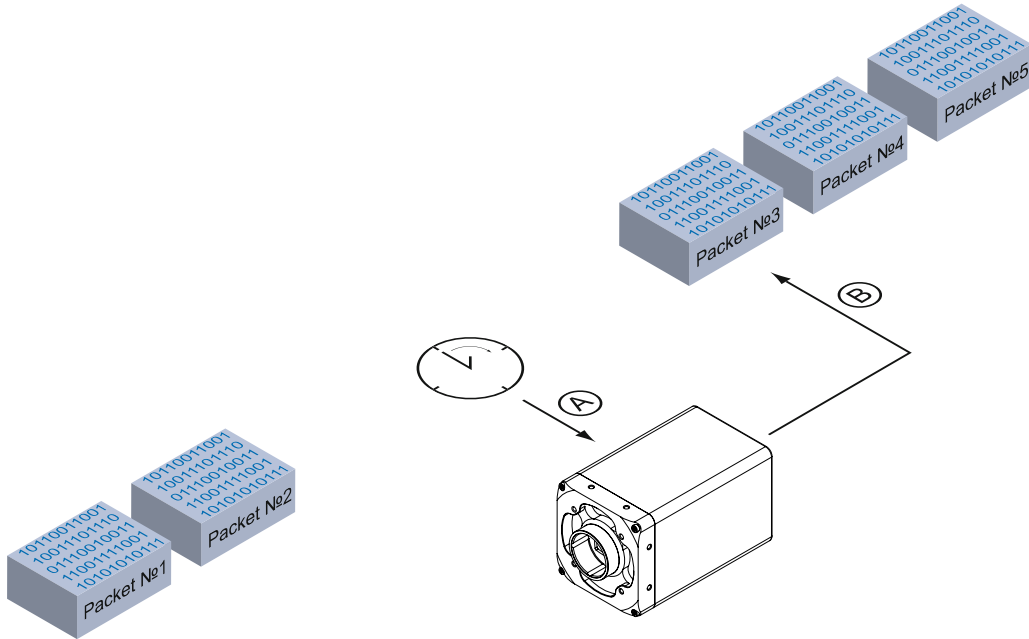

In our example, packets from no. 3 to no. 5 are lost. This fault is detected after the predefined time has elapsed and the resend request (A) is triggered. The camera then resends packets no. 3 to no. 5 (B) to complete the image transfer

8.7.4 Termination Conditions

The resend mechanism will continue until:

- all packets have reached the pc
- the maximum of resend repetitions is reached
- the resend timeout has occurred or
- the camera returns an error.

